

Pneumatic Instrumentation Equipment

For Pneumatic Control in

PA Process Automation **FA** Factory Automation



For Pneumatic Control in

PA

Process Automation

Air Preparation Equipment Page 97

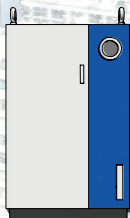

Compressor

Air Dryers



- Flow capacity: 65000 L/min (ANR)
- Outlet air pressure dew point: 10°C



- Flow capacity: 780 L/min (ANR)
- Outlet air atmospheric pressure dew point: -30°C

Air Preparation Filters



Micro Mist Separator with Prefilter

- Nominal filtration rating: 0.01 µm
- Odor Removal Filter
- Outlet oil mist concentration: Max. 0.0032 ppm

Detection Conversion Unit Page 74

Pressure Sensors



- Air: -0.1 to 1 MPa
- General fluids: -0.1 to 15 MPa

Flow Sensors



- Air: 0.2 to 12000 L/min (ANR)
- General fluids: 0.5 to 250 L/min (ANR)

Industrial Filters Page 101



- Flow capacity: Max. 3800 L/min (ANR)
- Nominal filtration rating: 0.5 to 120 µm

Pressure Control Equipment Page 37



- Set pressure range: 0.02 to 0.5 MPa
- Set pressure range: 0.005 to 0.8 MPa

Piping Material Page 104

Fittings/S Couplers

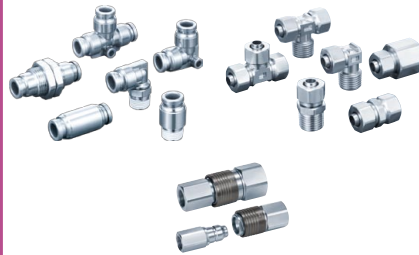

- Stainless steel series

Tubing

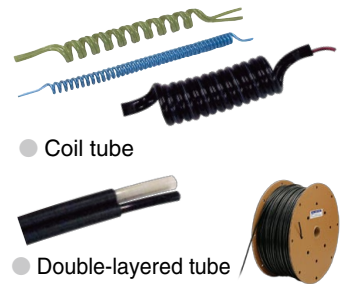

- Coil tube
- Double-layered tube
- Longer length tube

Operation Unit

Solenoid Valves Page 79

Explosion-proof Specifications



Intrinsically safe explosion proof

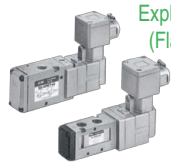

Explosion proof (Flameproof)

NAMUR Standards IP67



Accessories Page 52

Relay



Booster relay

Electro-Pneumatic Transducer



Electro-pneumatic transducer

Valves



Lock-up valve

Positioners Page 6



Smart positioner



Electro-pneumatic positioner

Actuators Page 62



- Applicable cylinder size: ø50 to ø300

Industrial process valve Actuator

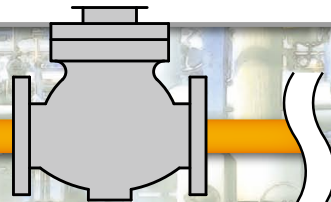
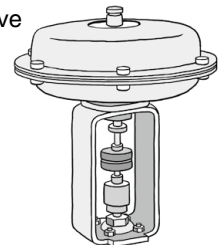
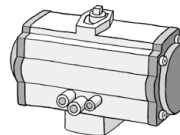

In principle, SMC products cannot be used outdoors.

INDEX

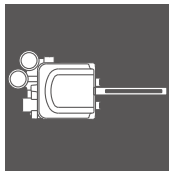

Positioners Page 6

Electro-Pneumatic Positioner/ IP8000/8100	Page 7
Smart Positioner/ IP8001/8101	Page 7
Pneumatic-Pneumatic Positioner/ IP5000/5100	Page 32
Cylinder Positioner/ IP200	Page 35

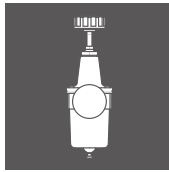

Regulators Page 37

Filter Regulator / IW	Page 38
Filter Regulator / 1301	Page 42
Filter Regulator: For Low Temperature Environment (-30 to 60°C)/High Temperature Environment (-5 to 80°C)/ AW-X430/-X440 ..	Page 45
Filter Regulator: Stainless Steel 316 and Special Temperature Environment (-40°C) Specifications/ AW30/40-X2622 ..	Page 47
Precision Regulator/ IR	Page 51



Relays/Valves Page 52

Relay	
Booster Relay/ IL100	Page 53
Valves	
Lock-Up Valve / IL201/211/220	Page 56



Electro-Pneumatic Transducers Page 59

Electro-Pneumatic Transducer/ IT600	Page 60
--	---------

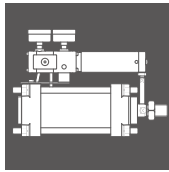

Actuators Page 62

P Cylinder (Cylinder with Positioner)/ CPA2	Page 63
CPS1	Page 63

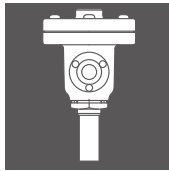

Detection Conversion Unit Page 74

Pressure Switches/Sensors	
Pressure Switch/Micro Switch Type/ IS100	Page 75
Pressure Switch/Reed Switch Type/ IS10	Page 77
Pressure Switch/Micro Switch Type/ IS3000	Page 77
General Purpose Pressure Switch/Snap Switch Type/ ISG	Page 77
2-Color Display High-Precision Digital Pressure Switch/ ZSE/ISE30A	Page 77
2-Color Display Digital Pressure Switch/ ISE70/75(H)	Page 77
2-Color Display Digital Pressure Switch/ ZSE/ISE80	Page 77
Flow Switches/Sensors	
2-Color Display Digital Flow Switch/ PFM	Page 78
2-Color Display Digital Flow Switch/ PFMB	Page 78
Digital Flow Switch for Air/ PF2A	Page 78
3-color Display Digital Flow Switch for Water/ PF3W	Page 78
3-color Display Electromagnetic Type Digital Flow Switch/ LFE □	Page 78
Diaphragm Style Flow Switch/ IFW5	Page 78
Paddle Style Flow Switch/ IF3	Page 78

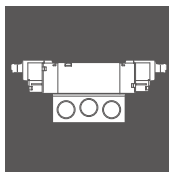

Solenoid Valves Page 79

Directional Control Valves	
NAMUR Interface 3 Port Solenoid Valve/ VFN200N	Page 80
NAMUR Interface 5 Port Solenoid Valve/ VFN2000N	Page 83
NAMUR Interface 3/5 Port Solenoid Valve/ IP67 Compliant, Hygienic Design Type/ VFN2120N-X23/-X36	Page 90
Intrinsically Safe Explosion-proof System 5 Port Solenoid Valve/ 51-SY	Page 96
Explosion-proof Type 3/5 Port Solenoid Valve/ 50-VFE/50-VPE	Page 96
Fluid Control Equipment	
Direct Operated 2 Port Solenoid Valve/ VX2	Page 96
Pilot Operated 2 Port Solenoid Valve/ VXD	Page 96

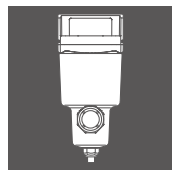

Air Preparation Equipment

Page 97

Aftercoolers

Air Cooled Aftercooler/ HAA	Page 98
Water Cooled Aftercooler/ HAW	Page 98

Air Tanks

Air Tank/ VBAT	Page 98
Air Tank/ AT	Page 98

Air Dryers

Refrigerated Air Dryer/ IDF/IDU□E, D	Page 98
Refrigerated Air Dryer/Large Size Series/ IDF□F	Page 98
Refrigerated Air Dryer: For Use in Europe, Asia, and Oceania/ IDFA□E	Page 98
Refrigerated Air Dryer/Large Size Series: For Use in Europe, Asia, and Oceania/ IDFA□F	Page 98
Refrigerated Air Dryer: For Use in North, Central and South America/ IDFB□E	Page 99
Heatless Air Dryer/ ID	Page 99
Membrane Air Dryer/ IDG	Page 99

Filters

Water Separator/ AMG	Page 99
Main Line Filter/ AFF	Page 99
Mist Separator/ AM	Page 99
Micro Mist Separator/ AMD	Page 99
Micro Mist Separator with Pre-filter/ AMH	Page 100
Super Mist Separator/ AME	Page 100
Odor Removal Filter/ AMF	Page 100

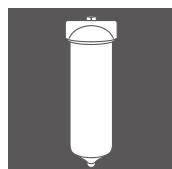

Industrial Filters

Page 101

Industrial Filters

Industrial Filter/ FGD	Page 102
Industrial Filter/ FGE	Page 102
Industrial Filter/ FGG	Page 102
Bag Filter/ FGF	Page 102
High Precision Filter for Liquids/ FGH	Page 102
Quick Change Filter/ FQ1	Page 102

Elements

Sintered Metal Filter Elements/ EB/ES	Page 103
Fiber Elements/ EH/EHM/EHK	Page 103
Paper Elements/ EP	Page 103
Micromesh Elements/ EM	Page 103



Piping Materials

Page 104

Tubing

Double-layered Tube for Instrumentation Device (Single-tubed/Double-tubed)/ IN-241	Page 105
T0604 to T1075-X120/121/166	Page 105
Reinforced Corrugated Cardboard Specification: Longer Length Reel/ T0604-X64/TH0604-X64	Page 107
Polyurethane Coil Tubing/ TCU	Page 110
Longer Length Reel/ -X3	Page 110

Fittings/S Couplers

Stainless Steel 316 One-touch Fittings/ KQG2	Page 110
Stainless Steel 316 Insert Fittings/ KFG2	Page 110
S Couplers: Stainless Steel Type/ KKA	Page 110

Positioners

Regulators

Relays/Valves

Electro-Pneumatic Transducers

Actuators

Detection Conversion Unit

Solenoid Valves

Air Preparation Equipment

Industrial Filters

Piping Materials

Pneumatic Instrumentation Equipment

Positioners



Electro-Pneumatic Positioner/IP8000/8100	Page 7
Smart Positioner/IP8001/8101	Page 7
Pneumatic-Pneumatic Positioner/IP5000/5100	Page 32
Cylinder Positioner/IP200	Page 35

Positioners

Regulators

Relays/Valves

Electro-Pneumatic Transducers

Actuators

Detection Conversion Unit

Solenoid Valves

Air Preparation Equipment

Industrial Filters

Piping Materials

Series IP8

Electro-Pneumatic Positioner/Smart Positioner (Lever type/Rotary type)



Dustproof / Waterproof

Passed by external organization on JIS F8007 (conforms to IEC 60529) IP65

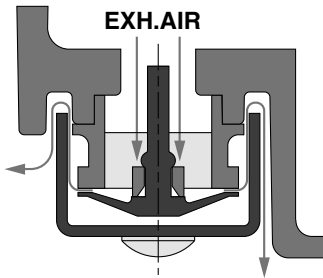

A centralized exhaust system employs the combination of the check valve and the labyrinth effect enhancing both dustproof and waterproof performance.

Monitoring function

Electro-Pneumatic Positioner

- Opening current transmission analog (4 to 20 mA DC) continuous output

Smart Positioner

- Alarm point output function (2 points)
- Analog (4 to 20 mA DC) continuous output

With external scale plate (Rotary type, Bottom mounting)



External scale plate

Improved visibility of opening indicator

Explosion-proof construction

Electro-Pneumatic Positioner	TIIS explosion-proof construction (Exd II BT5)
	ATEX intrinsically safe explosion-proof construction (II 2G Ex ib II CT5/T6)
Smart Positioner	ATEX intrinsically safe explosion-proof construction (II 1G Ex ia II CT4/T5/T6)

With internal opening indicator plate



Internal opening indicator plate

Opening indicator plate inside body

Body with LCD window

(Smart Positioner)



LCD window

Allows checking of control from outside body

Electro-Pneumatic Positioner

Universal mechanically controlled type
Series IP8000/8100



IP8000
(Lever type)



IP8100
(Rotary type)

Smart Positioner

Electronically controlled easy-adjustment transmitting type
Series IP8001/8101



IP8001
(Lever type)



IP8101
(Rotary type)

Smart Positioner

Series **IP8001/8101**

Built-in microcomputer and sensor allows easy remote parameter change and monitoring.

- Internal push button for easy setting of various parameters (Refer to parameter list)
- Zero point/span adjustment easier than with previous mechanical positioners

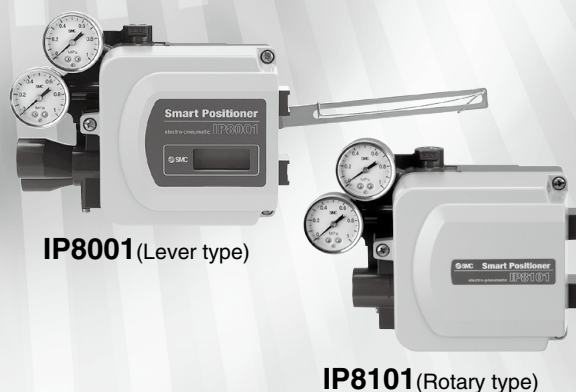

Positioners

Regulators

Relays/Valves

Electro-Pneumatic Transducers

Actuators

Detection Conversion Unit

Solenoid Valves

Air Preparation Equipment

Industrial Filters

Piping Materials

Parameter List

Notes	No	Parameter	Description
Standard equipped functions	1	Positive operation/reverse operation setting	Change operation direction with regard to input signal Change to internal components, piping not possible
	2	Split range setting	Change range of input signal
	3	Preferred zero point/span adjustment setting	Change actuator stroke range with regard to input signal
	4	Forced full close/full open setting	To ensure valve closure, force actuator opening to be 0% or 100% with a preferred input signal.
	5	Valve characteristic setting	Select from these 6 valve characteristics Linear characteristic Equality % characteristic (2 kinds) Quick open characteristic (2 kinds) User preferred point setting (11 points)
	6	PID constant setting	Change PID constant
	7	Calibration setting	Zero point/span adjustment, Auto PID constant setting, input signal display value calibration, etc.
Optional equipped functions	8	Alarm 1 output setting	Set upper/lower stroke limits for actuator from which alarm is output
	9	Alarm 2 output setting	Set upper/lower stroke limits for actuator from which alarm is output
	10	Analog (4 to 20 mA DC) output setting	Set increase/decrease direction for 4 to 20 mA DC output with regard to actuator stroke

Full Output Functions

Selecting models with output functions by model selection selects with alarm point output function (2 points) and analog (4 to 20 mA DC) continuous output function. This will allow remote detection of operating abnormalities.

Control State Display

Positioning, deviation, and input value are displayed (numerically) on the internal LCD, allowing visual verification of the control state.

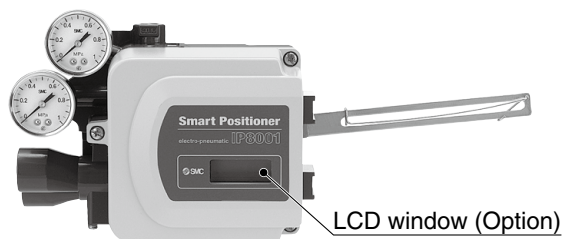

Display example

Positioning (%)	Input value (%)	Deviation (%)
P 50.0	S 60.0	E 10.0

Handles 2-line Input for Existing Equipment

Control furnished with conventional 2-line input signal (4 to 20 mA DC) not requiring separate power source.

HART Transmission Function

HART transmission function can be designated by model selection. Allows remote monitoring and setting change of positioner.

Intercompatible Installation

Dimensions of mounting parts same as previous mechanical series IP6000/IP8000 Electro-Pneumatic Positioner. External feedback lever and fork lever-type fitting for joining actuator and positioner are therefore also the same.

Energy Saving Product

Lever-type features 60% reduced air flow consumption compared with IP8000.

Smart Positioner (Lever type/Rotary type)



Series IP8001/8101

- Auto calibration
- Enclosure: JISF8007 IP65(conforms to IEC 60529)
- Explosion-proof construction/ATEX intrinsically safe explosion-proof construction (II 1G Ex ia II CT4/T5/T6)
- HART transmission function
- Monitoring function

How to Order

ATEX Directive Intrinsically Safe Explosion proof

Standard

Lever type IP8001

Rotary type IP8101

Type

001	Smart lever type
101	Smart rotary type

Pressure gauge

Symbol	Pressure gauge	Applicable model	
		IP8001	IP8101
1	0.2 MPa	●	—
2	0.3 MPa	●	—
3	1.0 MPa	●	●

Specifications

0	Basic type
2	With output function {Analog (4 to 20 mA DC) output + Alarm output x 2}
3	With HART transmission function

Specifications

4	Intrinsically safe explosion proof (ATEX) + output function + HART transmission function
---	--

ATEX directive compliance

52	ATEX directive category 1 Intrinsically safe explosion-proof item
----	--

ATEX temperature

Symbol	ATEX temperature	Applicable model	
		IP8001	IP8101
Nil	T4	●	●
T6	T5/T6	●	●

CE marking

Nil	—
Q	CE marked product

Connection

Symbol	Air	Electric
Nil	Rc1/4	G1/2
M ^{Note)}	Rc1/4	M20 x 1.5
N	Rc1/4	1/2NPT
1	1/4NPT	G1/2
2 ^{Note)}	1/4NPT	M20 x 1.5
3	1/4NPT	1/2NPT
4	G1/4	G1/2
5 ^{Note)}	G1/4	M20 x 1.5
6	G1/4	1/2NPT

^{Note)} When the symbol is M, 2, or 5 for 52-ATEX directive items, a blue cable gland is included with the electrical connection.

Accessories ^{Note 1)}

Symbol	Accessories	Applicable model	
		IP8001	IP8101
Nil	None (Standard)	●	●
C	Fork lever-type fitting M	—	●
D	Fork lever-type fitting S	—	●
E	For stroke 35 to 100 mm with lever unit ^{Note 2)}	●	—
F	For stroke 50 to 140 mm with lever unit ^{Note 2)}	●	—
H	With external scale plate ^{Note 3)}	—	●
W	Body with LCD window	●	●

Note 1) If two or more accessories are required, the part numbers should be given in alphabetical order. (ex. IP8101-010-CH)
 Note 2) Standard lever is not attached.
 Note 3) For side mounting, select "-W" and check the control position by viewing the LCD display value.

Positioners
Regulators
Relays/Valves
Electro-Pneumatic Transducers
Actuators
Detection Conversion Unit
Solenoid Valves
Air Preparation Equipment
Industrial Filters
Piping Materials

Specifications ^{Note 1)}

Type	IP8000		IP8100		IP8001	IP8101
	Electro-Pneumatic Positioner				Smart Positioner	
	Lever type lever feedback		Rotary type cam feedback		Lever type	Rotary type
Item	Single action	Double action	Single action	Double action	Single action / Double action	
Input current	4 to 20 mA DC (Standard) ^{Note 2)}					
Min. operating current	—				3.85 mA DC or more	
Intra-terminal voltage	—				12 V DC (equivalent to 600 Ω input resistance, at 20 mA DC)	
Max. supplied power	—				1 W (Imax: 100 mA DC, Vmax: 28 V DC)	
Input resistance	235 ± 15 Ω (4 to 20 mA DC)				—	
Supply air pressure	0.14 to 0.7 MPa				0.3 to 0.7 MPa	
Standard stroke	10 to 85 mm (Allowable deflection angle 10 to 30°)		60 to 100° ^{Note 3)}		10 to 85 mm (Allowable deflection angle 10 to 30°) 60 to 100° ^{Note 3)}	
Sensitivity ^{Note 4)}	Within 0.1% F.S.		Within 0.5% F.S.		Within 0.2% F.S.	
Linearity ^{Note 4)}	Within ±1% F.S.		Within ±2% F.S.		Within ±1% F.S.	
Hysteresis ^{Note 4)}	Within 0.75% F.S.		Within 1% F.S.		Within 0.5% F.S.	
Repeatability ^{Note 4)}	Within ±0.5% F.S.					
Coefficient of temperature	Within 0.1% F.S./°C				Within 0.05% F.S./°C	
Supply pressure fluctuation	Within 0.3% F.S./0.01 MPa				— ^{Note 5)}	
Output flow ^{Note 6)}	80 L/min (ANR) or more (SUP = 0.14 MPa)				200 L/min (ANR) or more (SUP = 0.4 MPa)	
Air consumption ^{Note 6)}	5 L/min (ANR) or less (SUP = 0.14 MPa) 11 L/min (ANR) or less (SUP = 0.4 MPa)		2 L/min (ANR) or less (SUP = 0.14 MPa) 4 L/min (ANR) or less (SUP = 0.4 MPa)		11 L/min (ANR) or less (SUP = 0.4 MPa)	
Ambient and fluid temperature	General structure: -20 to 80°C					
	TIIS explosion-proof: -20 to 60°C ATEX intrinsically safe explosion-proof: -20 to 80°C (T5) -20 to 60°C (T6) -40 to 60°C (T6)/-L type low-temperature specification			ATEX intrinsically safe explosion-proof -20 to 80°C (T4/T5) -20 to 60°C (T6)		
Explosion proof construction ^{Note 7)}	TIIS explosion-proof construction (Exd II BT5) ATEX intrinsically safe explosion-proof construction (II 2G Ex ib II CT5/T6)				ATEX intrinsically safe explosion-proof construction (II 1G Ex ia II CT4/T5/T6)	
ATEX intrinsically safe explosion-proof parameter (current circuit)	Ui ≤ 28 V, li ≤ 125 mA, Pi ≤ 1.2 W Ci ≤ 0 nF, Li ≤ 0 mH				Ui ≤ 28 V, li ≤ 100 mA, Pi ≤ 0.7 W Ci ≤ 12.5 nF, Li ≤ 1.5 mH	
Exterior covering enclosure ^{Note 8)}	JISF8007, IP65 (conforms to IEC Pub.60529)					
Transmission method ^{Note 7)}	—				HART transmission	
Air connection port ^{Note 9)}	Rc 1/4 female thread, NPT 1/4 female thread, G 1/4 female thread					
Electrical connection port ^{Note 9)}	G 1/2 female thread, M20 x 1.5 female thread, NPT 1/2 female thread					
Material/coating	Aluminum diecast body/baking finish with denatured epoxy resin					
Weight	2.4 kg (Without terminal box)/2.6 kg (With terminal box)				2.6 kg	

Note 1) Specification values are given at normal temperature (20°C).

Note 2) 1/2 Split range (Standard)

Note 3) Stroke adjustment: 0 to 60°, 0 to 100°

Note 4) Characteristics relating to accuracy differ depending on combination with other constituent loop equipment, such as positioners and actuators.

Note 5) While there is no output changes due to pressure fluctuations, when the pressure supply setting is changed following calibration, once again adjust balance current and perform calibration.

Note 6) (ANR) indicates JIS B0120 standard air.

Note 7) Model selection required for explosion proof construction and HART transmission.

Note 8) For IP66 compliant products, refer to pages 25 to 28.

Note 9) Thread type can be specified by model selection.

Optional Specifications

Item	Type	IP8100-0 <input type="checkbox"/> 1-J/JR (Non-explosion proof)	IP8 <input type="checkbox"/> 01-0 <input type="checkbox"/> 2 (Non-explosion proof)	52-IP8 <input type="checkbox"/> 01-0 <input type="checkbox"/> 4	
		Electro-Pneumatic Positioner	Smart Positioner		
Analog output	Wiring	2-line			
	Output signal	4 to 20 mA DC			
	Power supply voltage	12 to 35 V DC	10 to 28 V DC		
	Load resistance	(Power supply voltage - 12 V) ÷ 20 mA DC or less	0 to 750 Ω		
	Accuracy	±2% F.S. or less ^{Note 1)}	±0.5% F.S. or less ^{Note 2)}		
	Hysteresis	Within 1% F.S.	—		
Alarm output 1, 2	Wiring	—	2-line		
	Applicable standards	—	—	DIN19234/NAMUR Standard	
	Power supply voltage	—	10 to 28 V DC	5 to 28 V DC	
	Load resistance	—	10 to 40 mA DC	(Constant current output)	
	Alarm ON	—	R = 350 Ω ±10%	≥ 2.1 mA DC	
	Alarm OFF (Leakage current)	—	0.5 mA DC or less	≤ 1.2 mA DC	
	Response time	—	50 msec or less		

Note 1) Indicates analog output accuracy with respect to actuator angle.

Note 2) Indicates analog output accuracy with respect to LCD display position value (P value).

Accessory/Option

Pilot valve with output restriction (IP8000/8100)

In general, mounting on a small-size actuator may cause hunting. For prevention, a pilot valve with a built-in output restriction is available. The restriction is removable.

Actuator capacity	Orifice size	Part number	Pilot unit part number	Model selection accessory
90 cm ³	ø0.7	P36801080	P565010-18	A
180 cm ³	ø1	P36801081	P565010-19	B

Note) Output orifice not required for Smart Positioner regardless of actuator capacity.

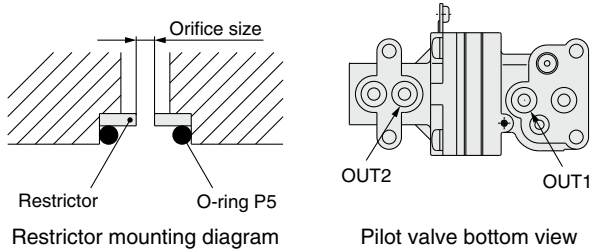

Fork lever-type fittings (IP8100/8101)

2 kinds of rotary type IP8100/8101 fork lever-type fittings, that differ by installation dimensions dependent on bracket installation method, and 2 kinds of installation portion thread sizes, are available.

When installing on the side surface, using fork lever assembly M provides interchangeability with the installation dimensions of SMC IP610 positioner. When installing on the rear surface, using fork lever assembly S also provides interchangeability with the installation dimensions of SMC IP610 positioner.

Part name	Unit number	Installation portion thread size	Model selection accessory
Fork lever assembly M	P368010-24	M8 x 1.25	C
Fork lever assembly S	P368010-25		D
Fork lever assembly MX	P368010-36	M6 x 1	C (Note)
Fork lever assembly SX	P368010-37		D (Note)

Note) Installation portion thread size is M6 x 1 for IP8100-0 -X14 when accessory C or D are selected.

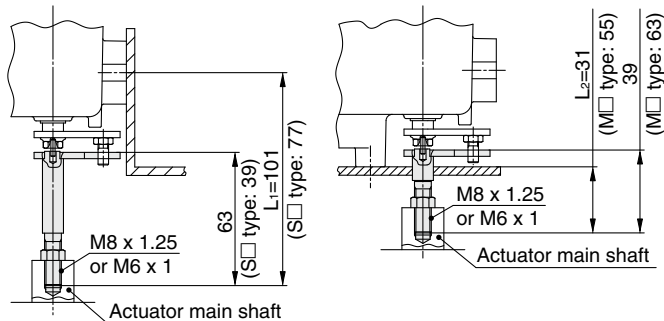

Side mounting with the fork lever assembly M

Rear mounting with the fork lever assembly S

External feedback lever (IP8000/8001)

Different feedback levers are available dependent upon valve strokes. Order according to the valve stroke.

Feedback lever types

Stroke	Unit number		Size M	Size N	Model selection accessory
	IP8000	IP8001			
10 to 85 mm	P368010-20	P565010-323	125	150	Standard accessory
35 to 100 mm	P368010-21	P565010-324	110	195	E
50 to 140 mm	P368010-22	P565010-325	110	275	F
6 to 12 mm	P368010-260	P565010-329	75	75	Available as special order

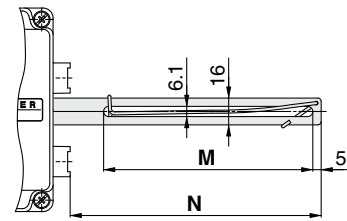

Resin connector (Non-explosion proof specification)

Optional cable connectors are available for different cable sizes. These are not for explosion proof applications. Recommended for use with indoor applications.

Part name	Part number	Suited cable outer diameter
Resin-made cable clamp unit (A)	P368010-26	ø7 to ø9
Resin-made cable clamp unit (B)	P368010-27	ø9 to ø11

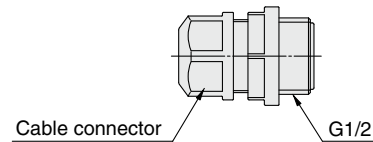

Series IP8

Exploded View

IP8000

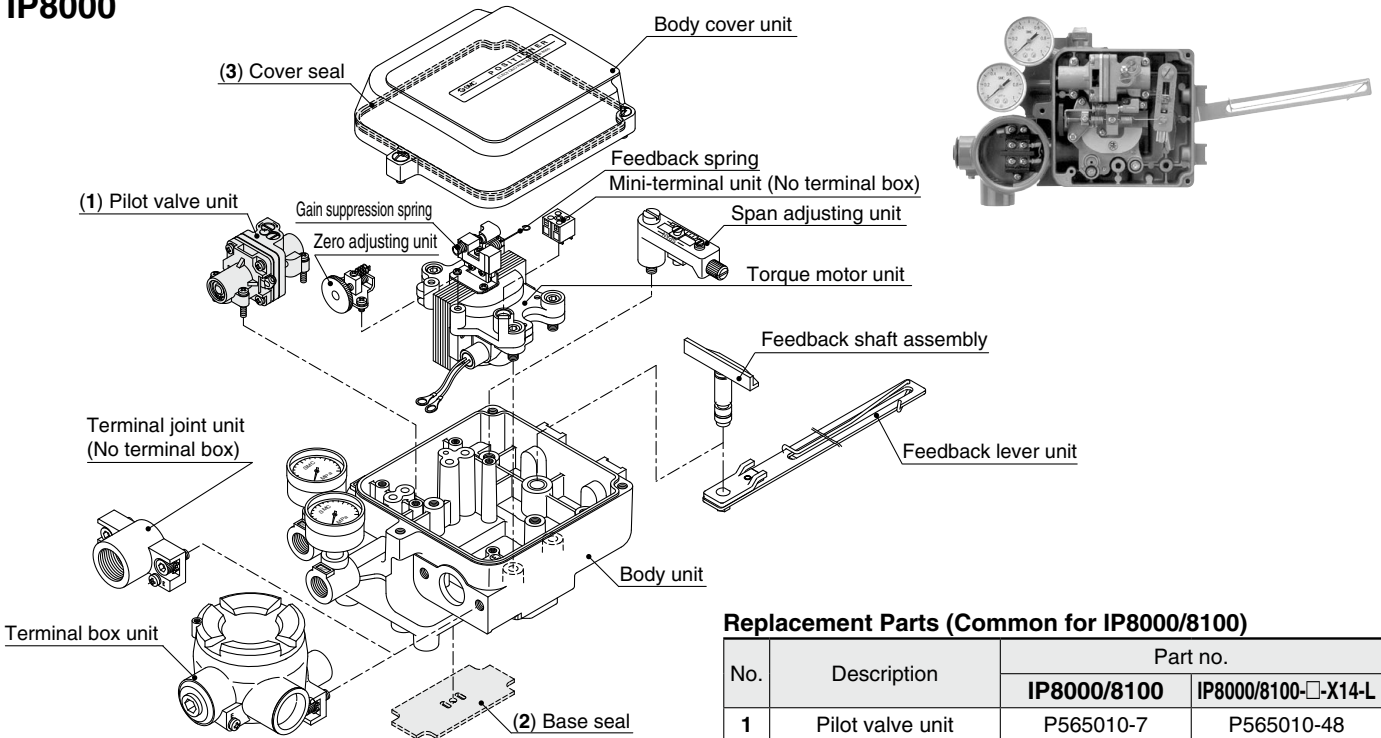

Replacement Parts (Common for IP8000/8100)

No.	Description	Part no.	
		IP8000/8100	IP8000/8100- <input type="checkbox"/> -X14-L
1	Pilot valve unit	P565010-7	P565010-48
2	Base seal	P56501012-3	
3	Cover seal	P56501013	

IP8101

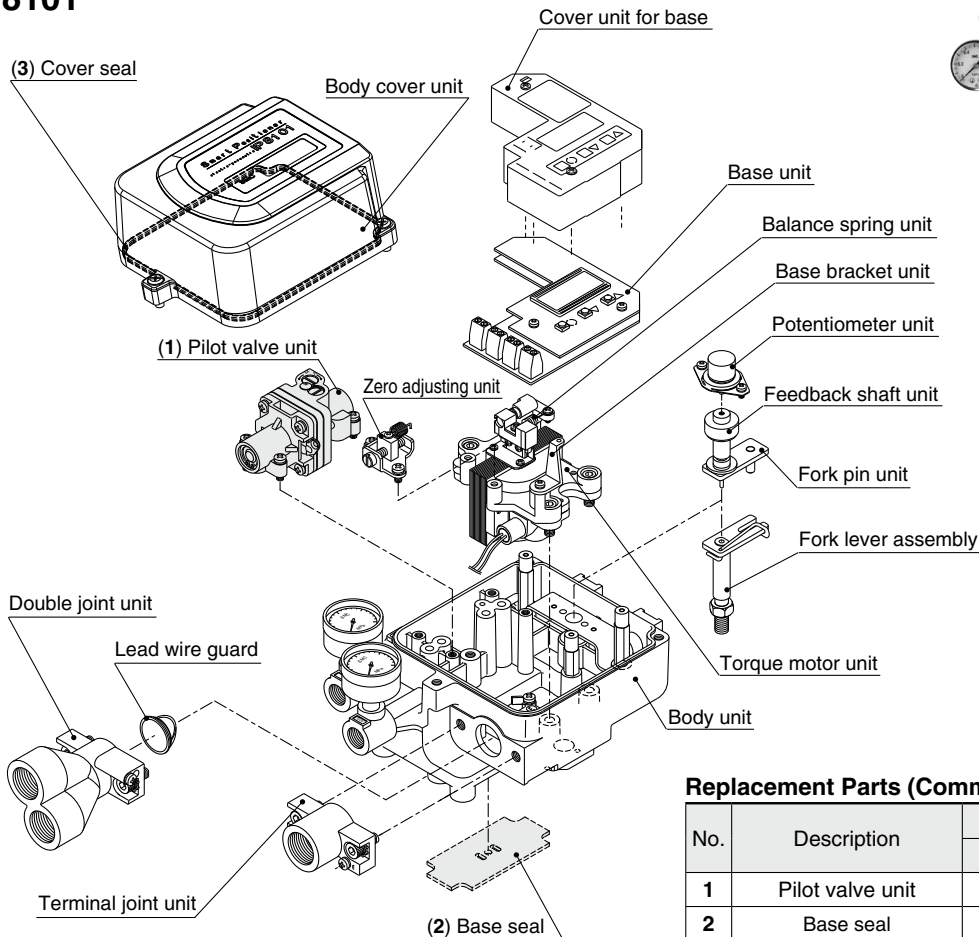

Replacement Parts (Common for IP8001/8101)

No.	Description	Part no.	
		IP8001	IP8101
1	Pilot valve unit	P565010-322	P565010-303
2	Base seal	P56501012-3	
3	Cover seal	P56501013	

Piping Note) When the input signal is discontinued, the pressure of OUT1 decreases, and the pressure of OUT2 increases.

IP8000/Lever type

	Single action		Double action	
Positive operation	<p>When the input signal is increased, the stem moves as allow mark.</p> <p>OUT2 is plugged.</p>	<p>When the input signal is increased, the stem moves as allow mark. (Positive valve operation by its reverse operation mode)</p> <p>OUT1 is plugged.</p>	<p>When the input signal is increased, the cylinder rod moves as allow mark.</p> <p>Span adjusting lever normal position</p>	
	<p>When the input signal is increased, the stem moves as allow mark. (Reverse valve operation by its positive operation mode)</p> <p>OUT1 is plugged.</p>	<p>When the input signal is increased, the stem moves as allow mark.</p> <p>OUT2 is plugged.</p>		<p>When the input signal is increased, the cylinder rod moves as allow mark.</p> <p>Span adjusting lever reverse position</p>

IP8100/Rotary type

	Single action		Double action	
Positive operation	<p>When the input signal is increased, the actuator shaft rotates in a clockwise direction.</p> <p>OUT2 is plugged.</p>	<p>When the input signal is increased, the actuator shaft rotates in a clockwise direction. (Positive valve operation by its reverse operation mode)</p> <p>OUT1 is plugged.</p>	<p>When the input signal is increased, the actuator shaft rotates in a clockwise direction.</p> <p>The cam of the positioner should be set on the DA surface.</p>	
	<p>When the input signal is increased, the actuator shaft rotates in a counter clockwise direction. (Reverse valve operation by its positive operation mode)</p> <p>OUT2 is plugged.</p>	<p>When the input signal is increased, the actuator shaft rotates in a counter clockwise direction.</p> <p>OUT2 is plugged.</p>		<p>When the input signal is increased, the actuator shaft rotates in a counter clockwise direction.</p> <p>The cam of the positioner should be set on the RA surface.</p>

Positioners

Regulators

Relays/Valves

Electro-Pneumatic Transducers

Actuators

Detection Conversion Unit

Solenoid Valves

Air Preparation Equipment

Industrial Filters

Piping Materials

Piping

Note) When the input signal is discontinued, the pressure of OUT1 decreases, and the pressure of OUT2 increases.
Caution is also similarly required when changing the control direction in parameter mode.

IP8001/Lever type

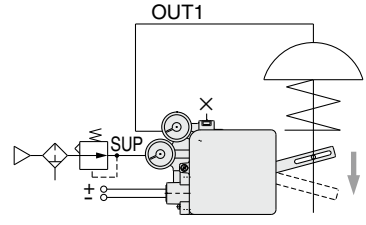
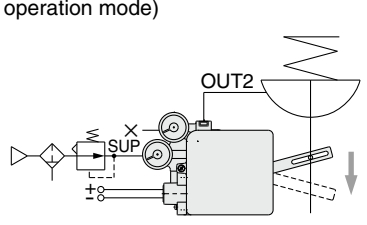
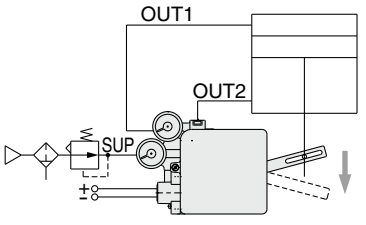
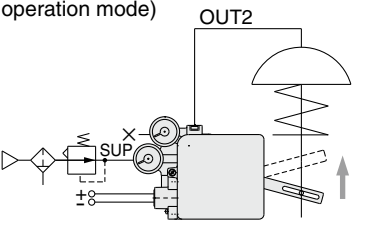
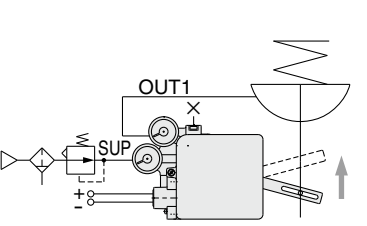
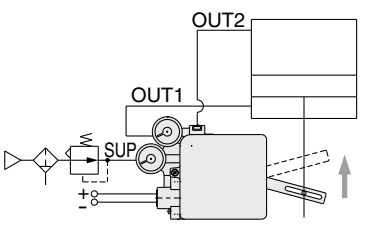
	Single action	Double action	
Positive operation	<p>When the input signal is increased, the stem moves as allow mark.</p>  <p>OUT2 is plugged.</p>	<p>When the input signal is increased, the stem moves as allow mark. (Positive valve operation by its reverse operation mode)</p>  <p>OUT1 is plugged.</p>	<p>When the input signal is increased, the cylinder rod moves as allow mark.</p> 
Reverse operation	<p>When the input signal is increased, the stem moves as allow mark. (Reverse valve operation by its positive operation mode)</p>  <p>OUT1 is plugged.</p>	<p>When the input signal is increased, the stem moves as allow mark.</p>  <p>OUT2 is plugged.</p>	<p>When the input signal is increased, the cylinder rod moves as allow mark.</p> 

IP8101/Rotary type

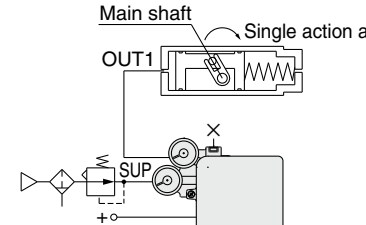
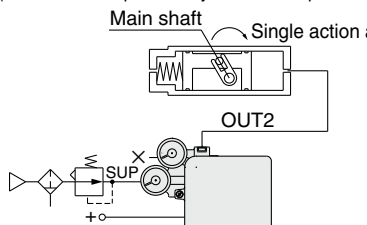
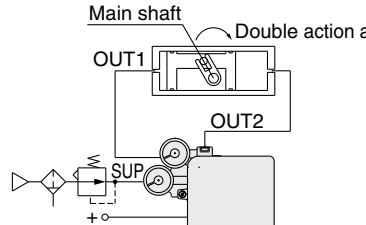
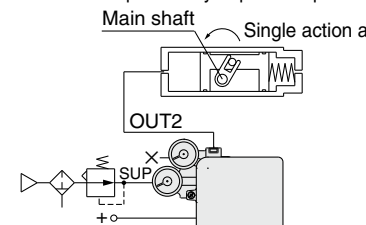
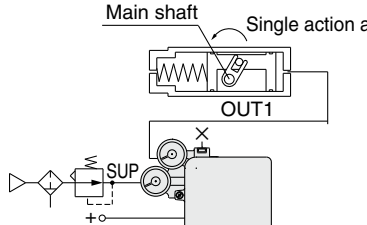
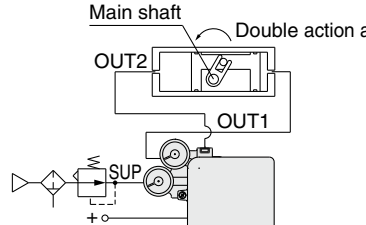
	Single action	Double action	
Positive operation	<p>When the input signal is increased, the actuator shaft rotates in a clockwise direction.</p>  <p>OUT2 is plugged.</p>	<p>When the input signal is increased, the actuator shaft rotates in a clockwise direction. (Positive valve operation by its reverse operation mode)</p>  <p>OUT1 is plugged.</p>	<p>When the input signal is increased, the actuator shaft rotates in a clockwise direction.</p> 
Reverse operation	<p>When the input signal is increased, the actuator shaft rotates in a counter clockwise direction. (Reverse valve operation by its positive operation mode)</p>  <p>OUT1 is plugged.</p>	<p>When the input signal is increased, the actuator shaft rotates in a counter clockwise direction.</p>  <p>OUT2 is plugged.</p>	<p>When the input signal is increased, the actuator shaft rotates in a counter clockwise direction.</p> 

Installation

IP8000/8001 (Lever type)

1. Create brackets that are appropriate for the positioner and diaphragm valve mounting methods, and affix it firmly using the mounting hole on the side or rear surface.

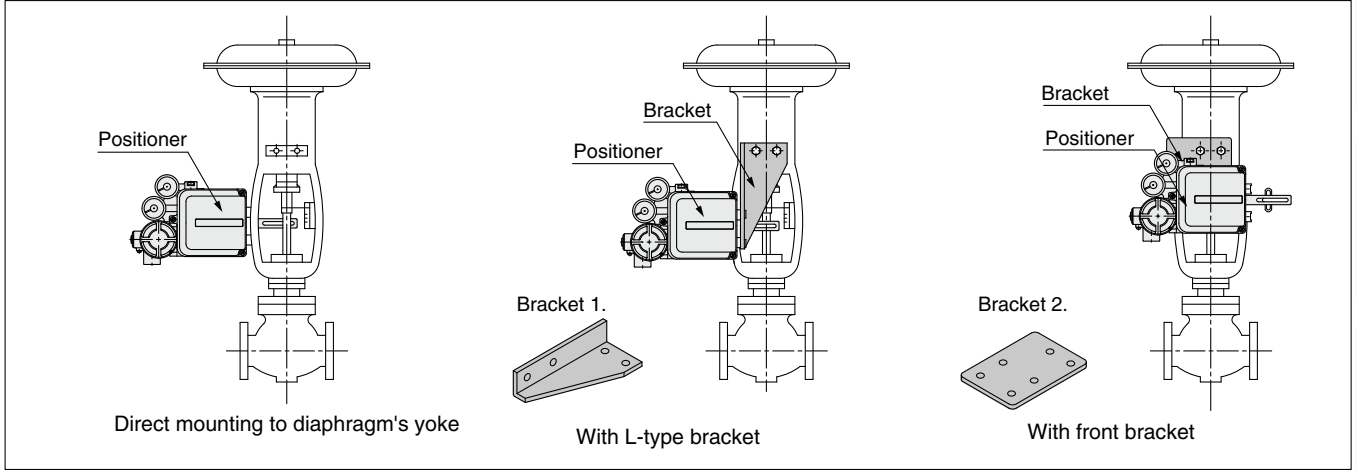

2. The feedback lever that detects the displacement of valve stems should be mounted at a position so that the lever is at right angles to the valve stem for an input current of 50%. The figure is the configuration viewed from the front.

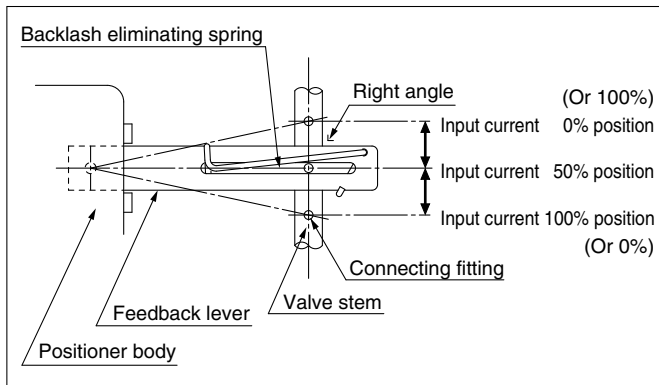

3. Brackets for lever type positioners, which are compliant with NAMUR and DIN/IEC 60534-6-1 are now available.

Description	Part no.
Bracket (NAMUR compliant) single unit	INI-224-0-56

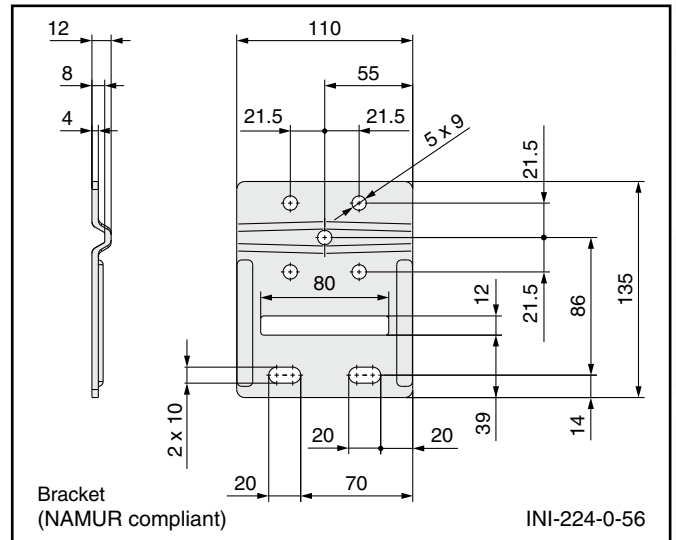

IP8100/8101 (Rotary type)

1. The positioner should be mounted so that the feedback shaft is aligned with the shaft of the rotary actuator.

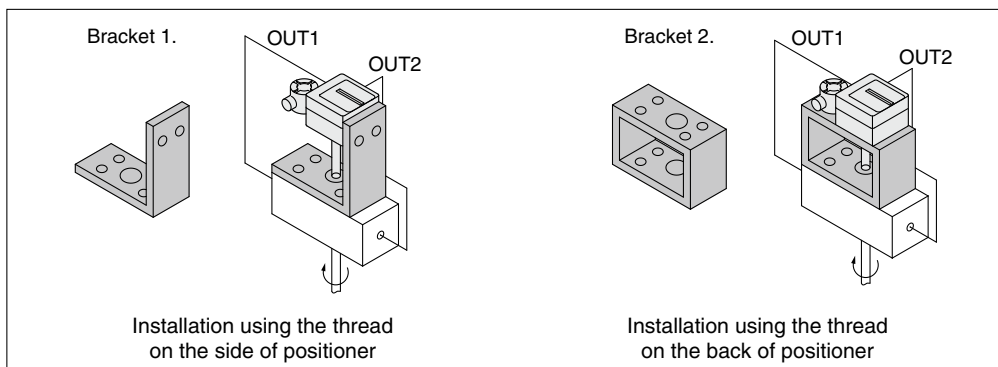

Principle of Operation

IP8000/Lever type

When the input current increases, (11) the plate spring of (12) the torque motor will work as a pivot, (13) armature will receive a counter clockwise torque, (4) the counter weight will be pushed to the left, the clearance between (6) the nozzle and (5) the flapper will increase, and the nozzle back pressure will decrease. Consequently, (7) the exhaust valve of (1) the pilot valve moves to the right, the output pressure of OUT1 increases and (15) the diaphragm moves downwards. The motion of (15) the diaphragm acts on (10) the feedback spring through (8) the feedback lever, (14) the transmission lever and (9) the span adjustment lever to rest at the balance position generated by the input current. (2) The gain suppression spring is for direct feedback of the motion of (7) the exhaust valve to (4) the counter weight to increase the stability of the loop. The zero point should be adjusted by change of (3) the zero adjustment spring tension.

Single action positive operation

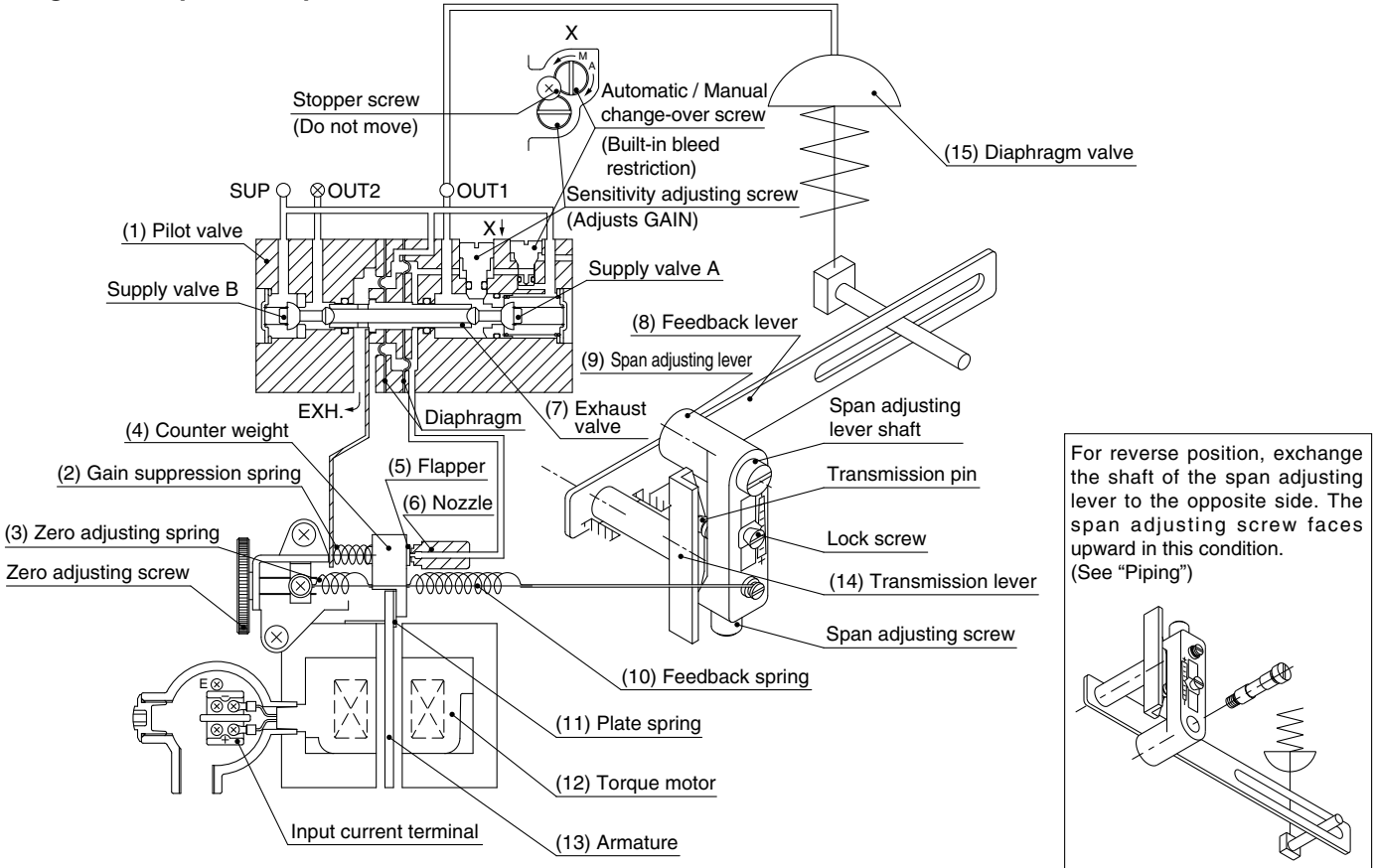

Block diagram

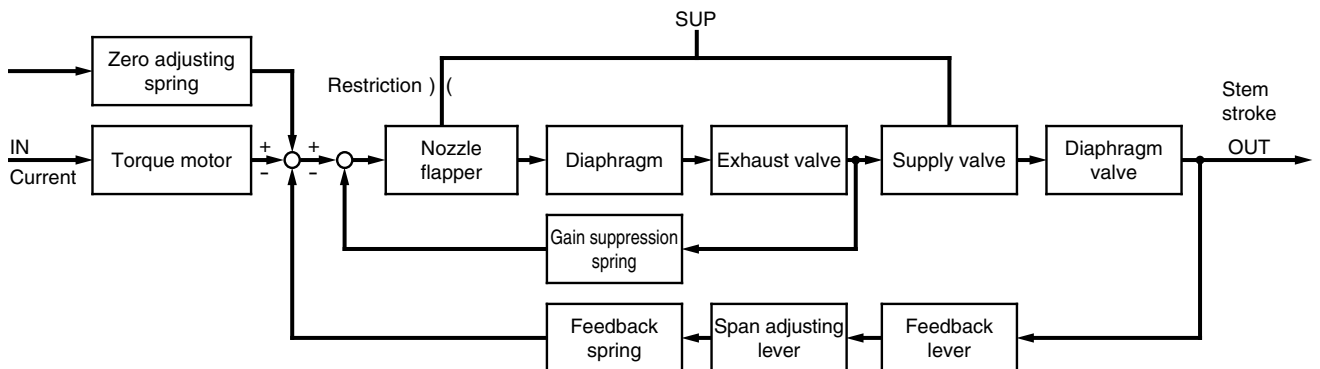

IP8100/Rotary type

When the input current increases, (12) the plate spring of (13) the torque motor will work as a pivot, (14) armature will receive a counter-clockwise torque, (4) the counter weight will be pushed to the left and the clearance between (6) the nozzle and (5) the flapper will increase, and the nozzle back pressure will decrease. Consequently, (7) the exhaust valve of (1) the pilot valve moves to the right, the output pressure of OUT1 increases that of OUT2 decreases and (16) the rotary actuator moves. The motion of (16) the actuator acts on (10) the feedback spring through (11) the feedback shaft, (8) the cam, (9) the span adjustment lever and (15) transmission lever to rest at the balance position generated by the input current. (8) the cam is set on the DA surface and operates positively while (16) the oscillating actuator shaft rotates in a clockwise direction when the input signal is increased. (2) The gain suppression spring is for direct feedback of the motion of (7) the exhaust valve to (4) the counter weight to increase the stability of the loop. The zero point should be adjusted by change of (3) the zero adjustment spring tension.

Double action positive operation

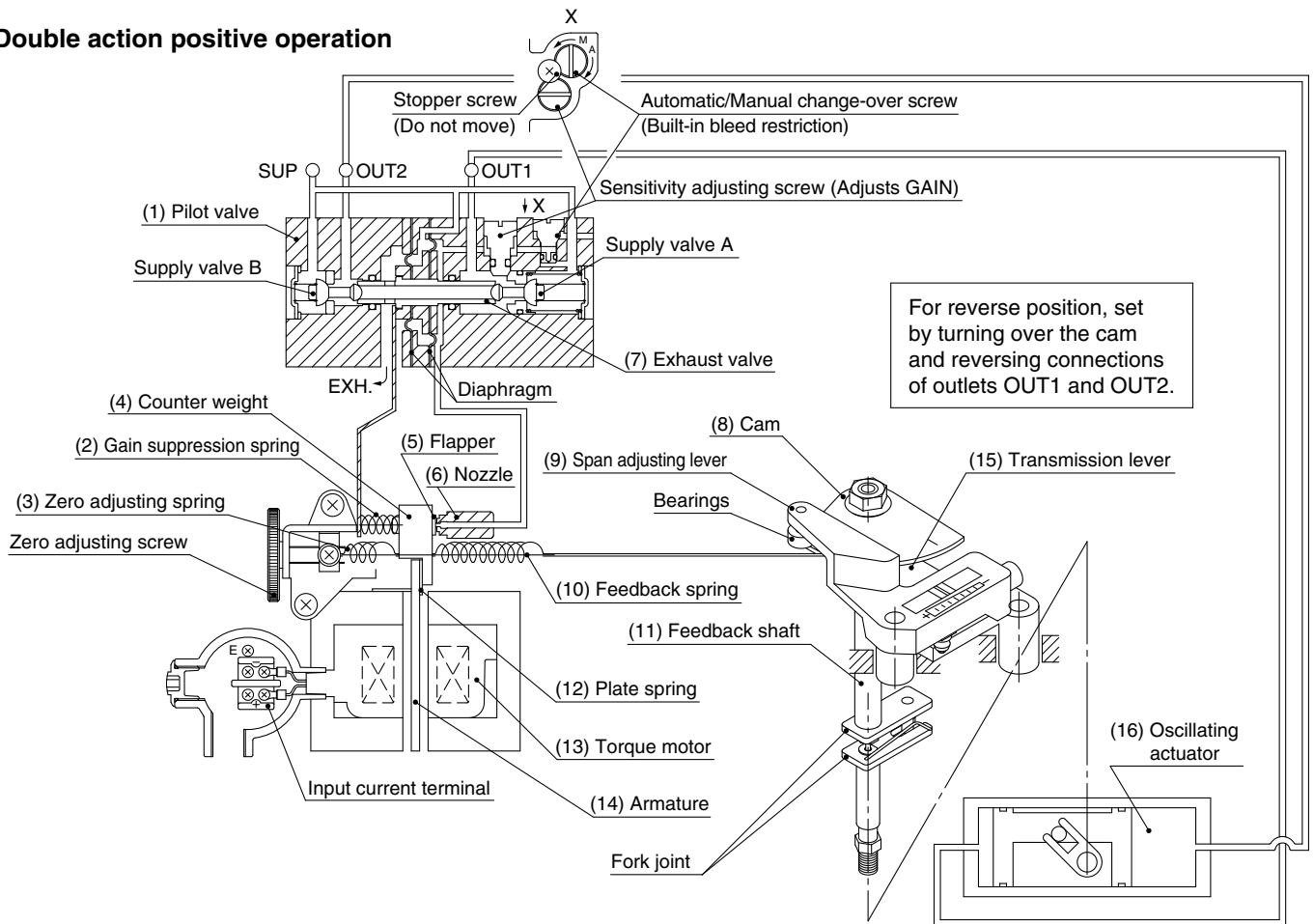

Block diagram

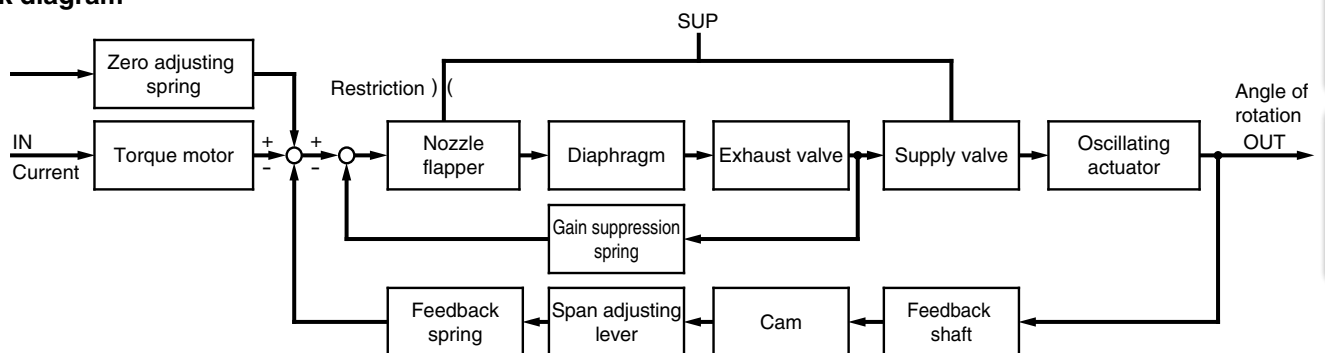

Principle of Operation

IP8001/Lever type

When the input current increases, the electrical current inside (12) the torque motor coil will change through (8) the plate's input process, operation process and output process, and (13) the armature will oscillate, with (11) the plate spring as its base. As a result, the clearance between (6) the nozzle and (5) the flapper will increase, and the nozzle back pressure will decrease. Consequently, (7) the exhaust valve of (1) the pilot valve moves to the right, the output pressure of OUT1 increases and causes (15) the diaphragm valve to move. The motion of (15) the diaphragm valve is transmitted to the displacement output process of (8) the board through (14) the feedback lever, (10) the feedback shaft and (9) angle sensor, and the calculated output position will match the input current.

Single action positive operation

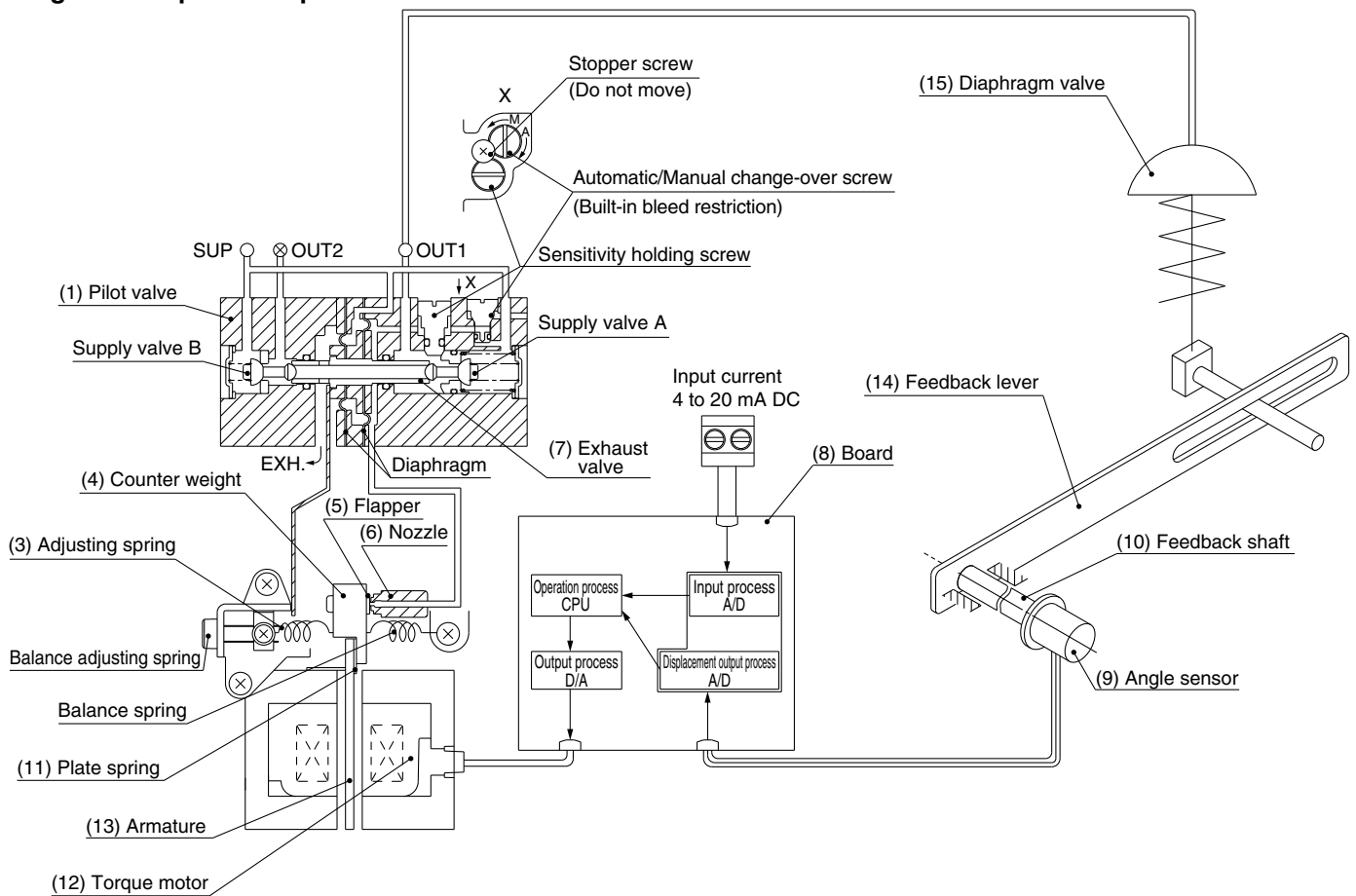

Block diagram

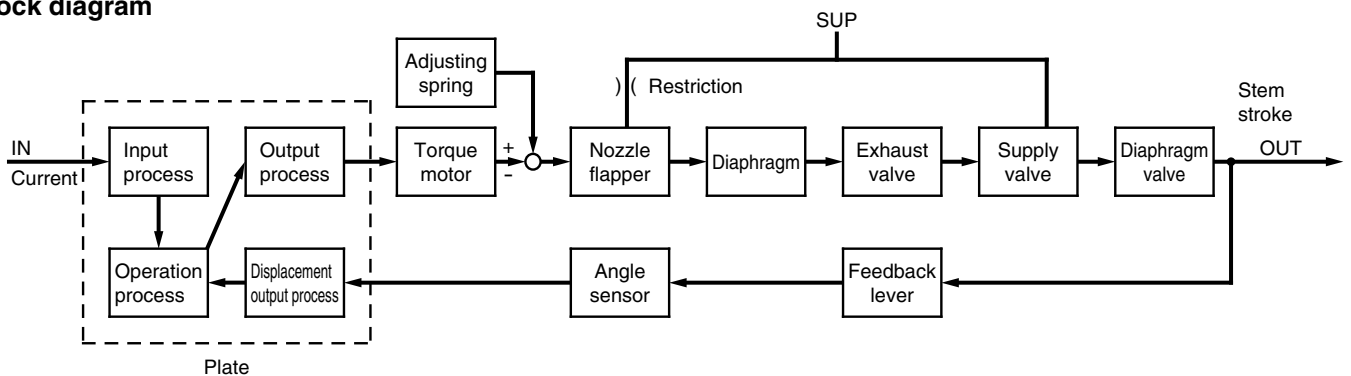

IP8101/Rotary type

When the input current increases, the electrical current inside (12) the torque motor coil will change through (8) the plate's input process, operation process and output process, and (13) the armature will oscillate, with (11) the plate spring as its base. As a result, the clearance between (6) the nozzle and (5) the flapper will increase, and the nozzle back pressure will decrease. Consequently, (7) the exhaust valve of (1) the pilot valve moves to the right, the output pressure of OUT1 increases and causes the output pressure of OUT2 to decrease, causing (14) the oscillating actuator to move. The motion of (14) the oscillating actuator is transmitted to the fork lever-type fitting, (10) the feedback shaft (9) angle sensor, and the displacement output process of (8) the board, and output position will match the input current.

Double action positive operation

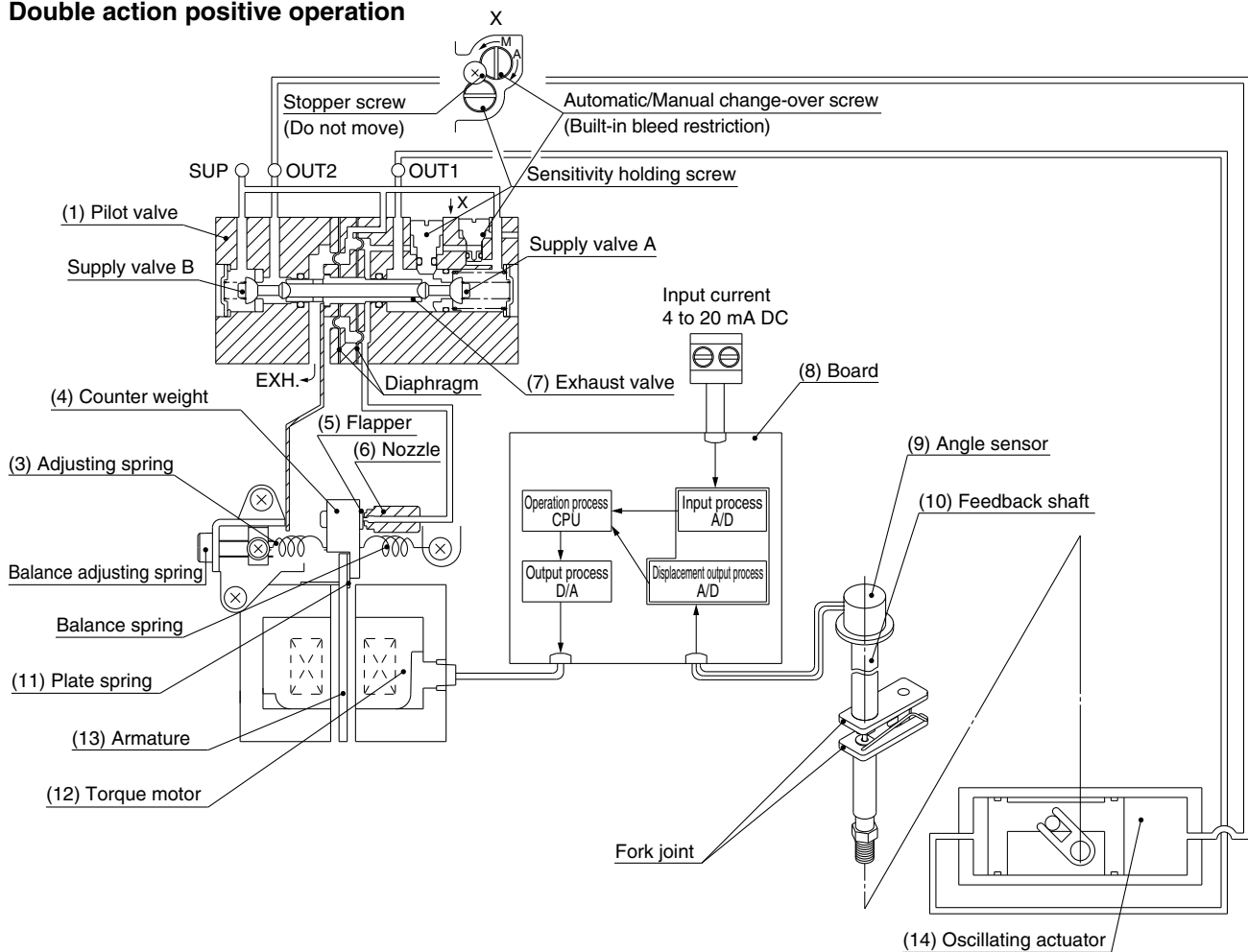

Block diagram

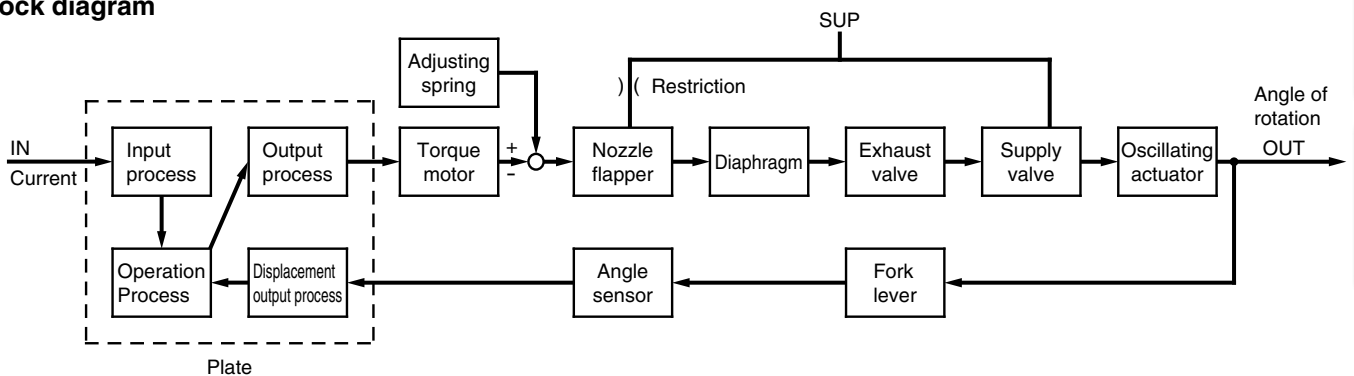

Dimensions/IP8000 (Lever type)

IP8000-00 (Without terminal box)

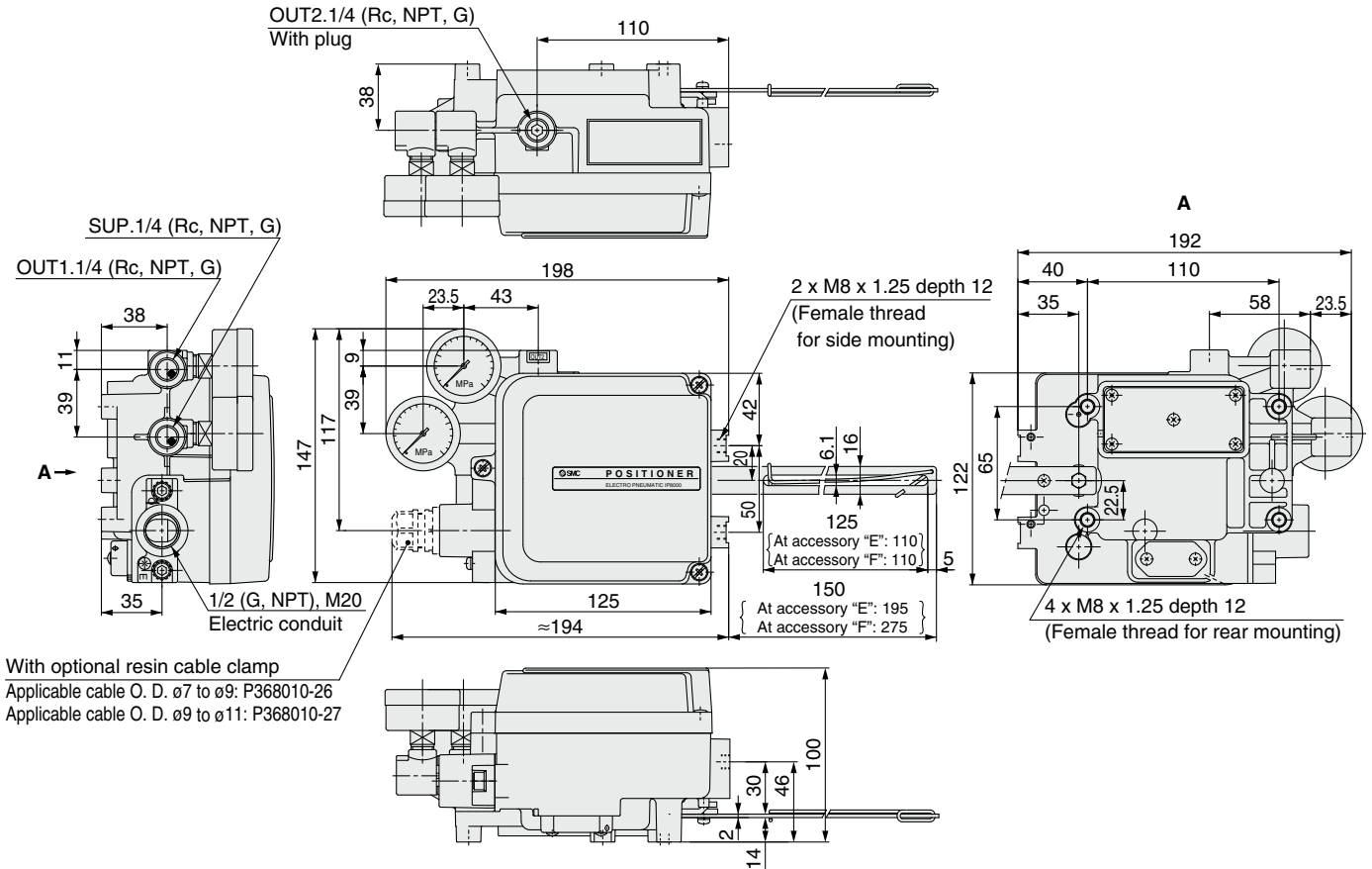

IP8000-01 (With terminal box)

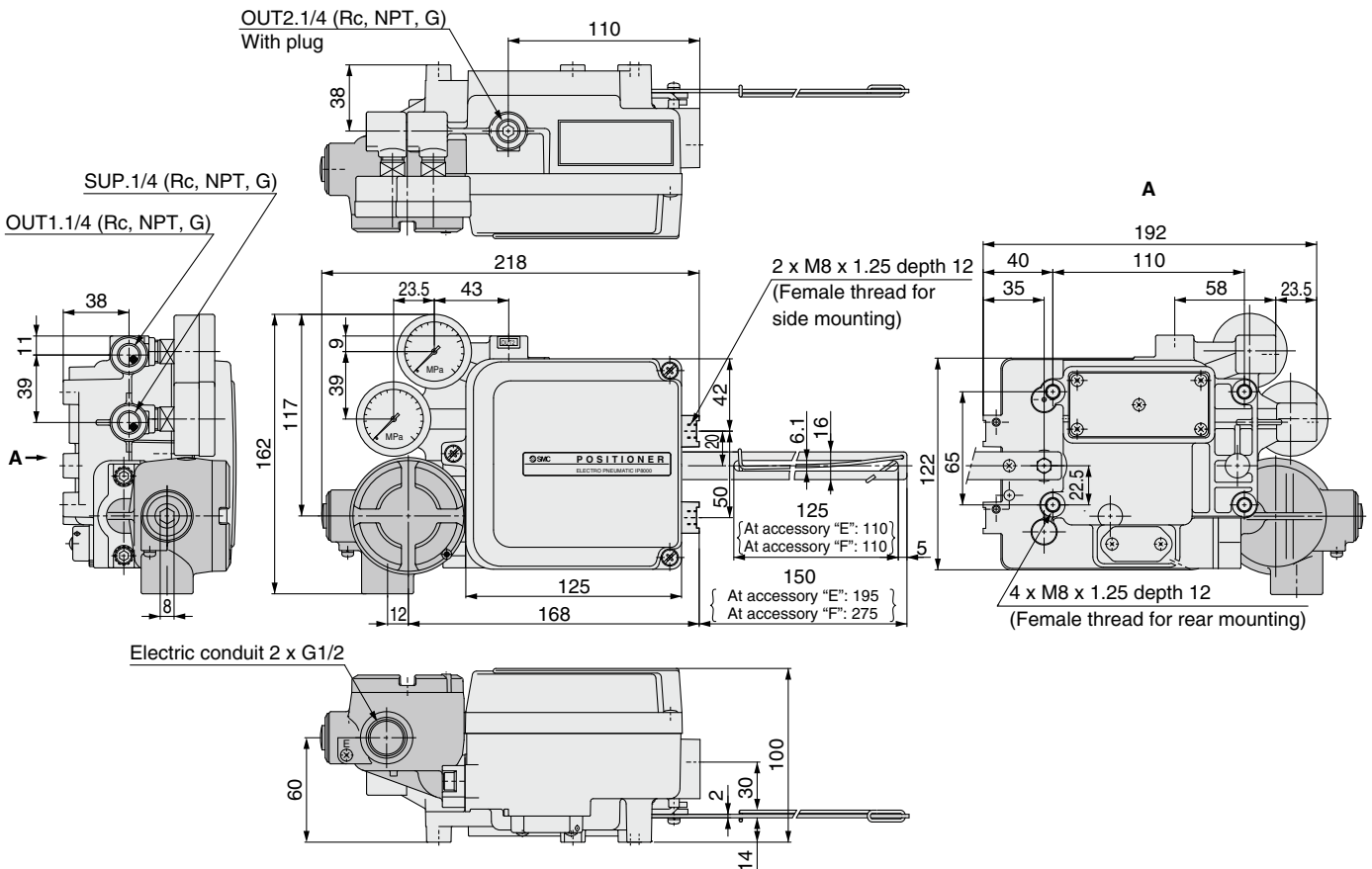

Dimensions/IP8100 (Rotary type)

IP8100-0□0 (Without terminal box)

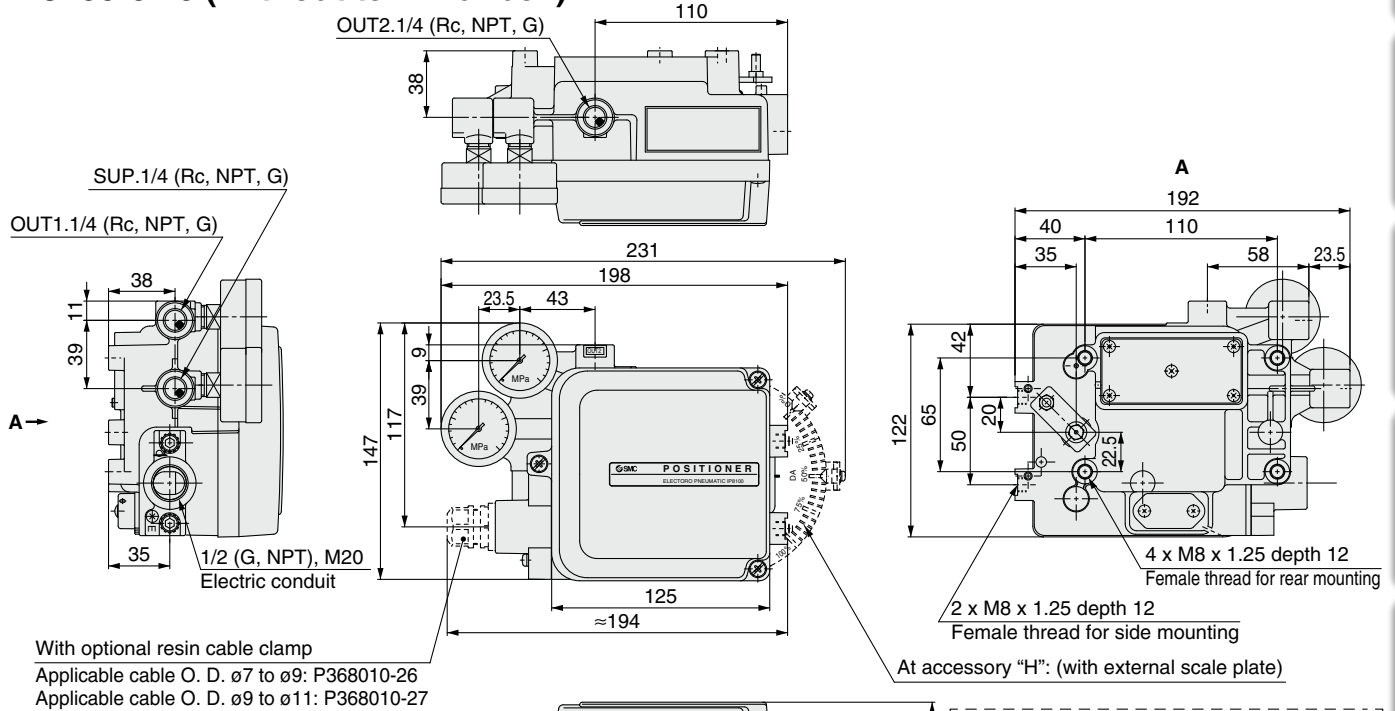

IP8100-0□1 (With terminal box)

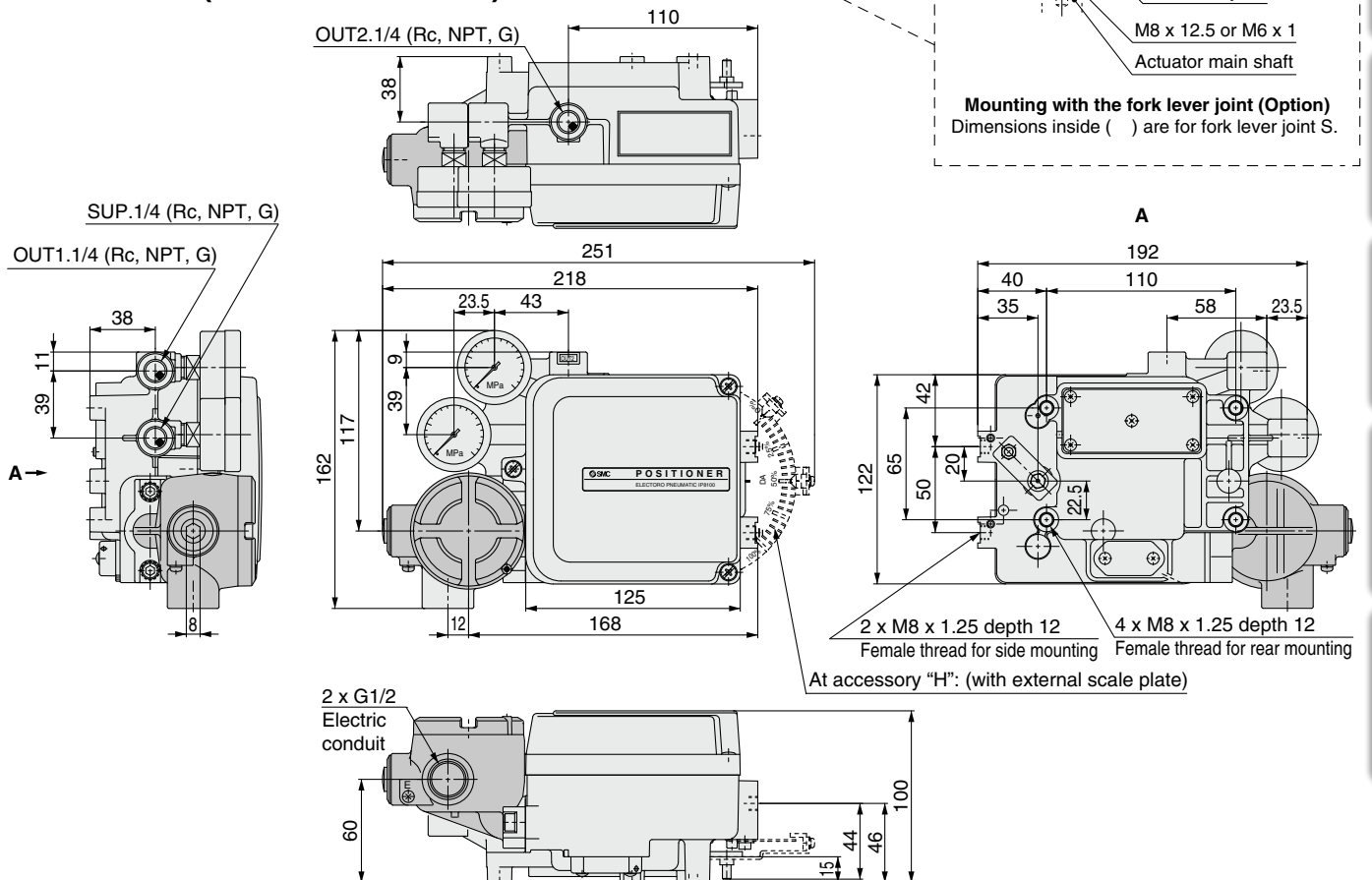

Dimensions/IP8001 (Lever type)

IP8001- $\begin{matrix} 0\Box 0 \\ 0\Box 3 \end{matrix}$

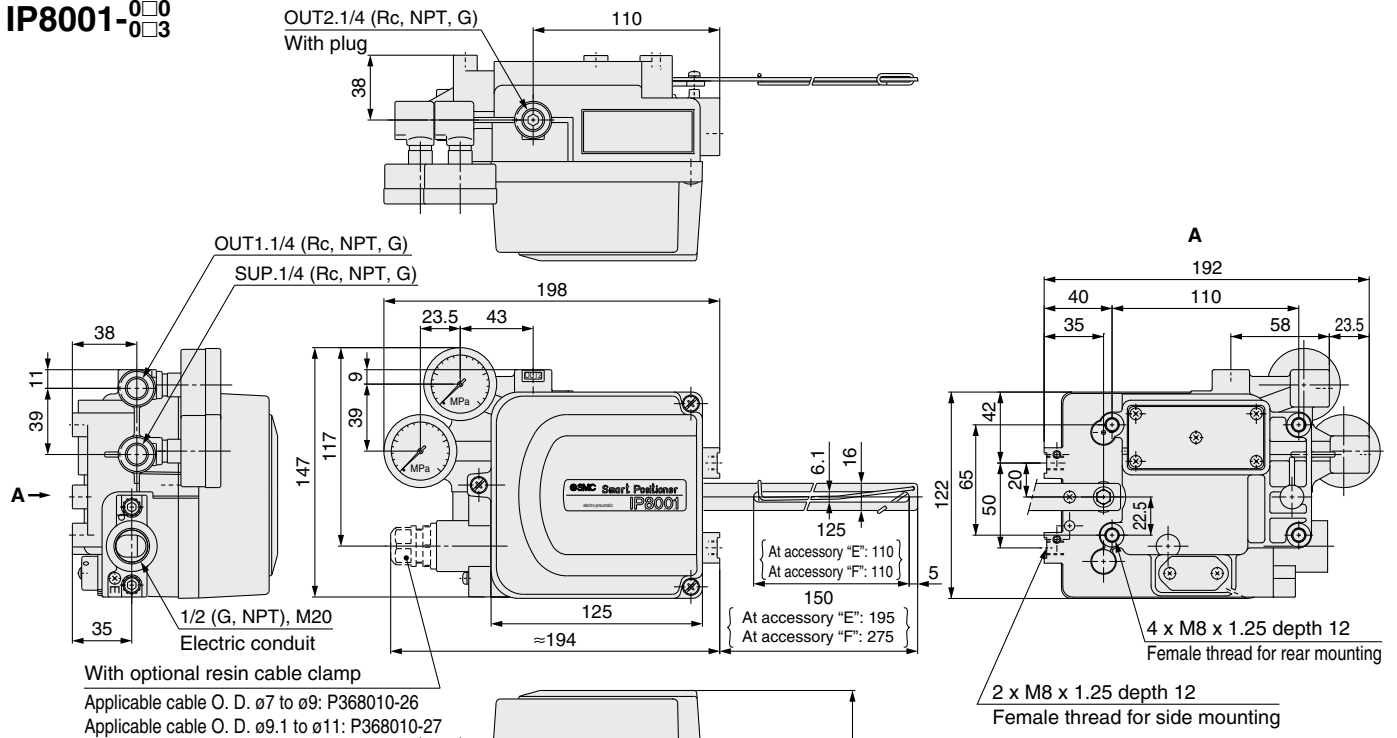

□-IP8001- $\begin{matrix} 0\Box 2 \\ 0\Box 4 \end{matrix}$ -W

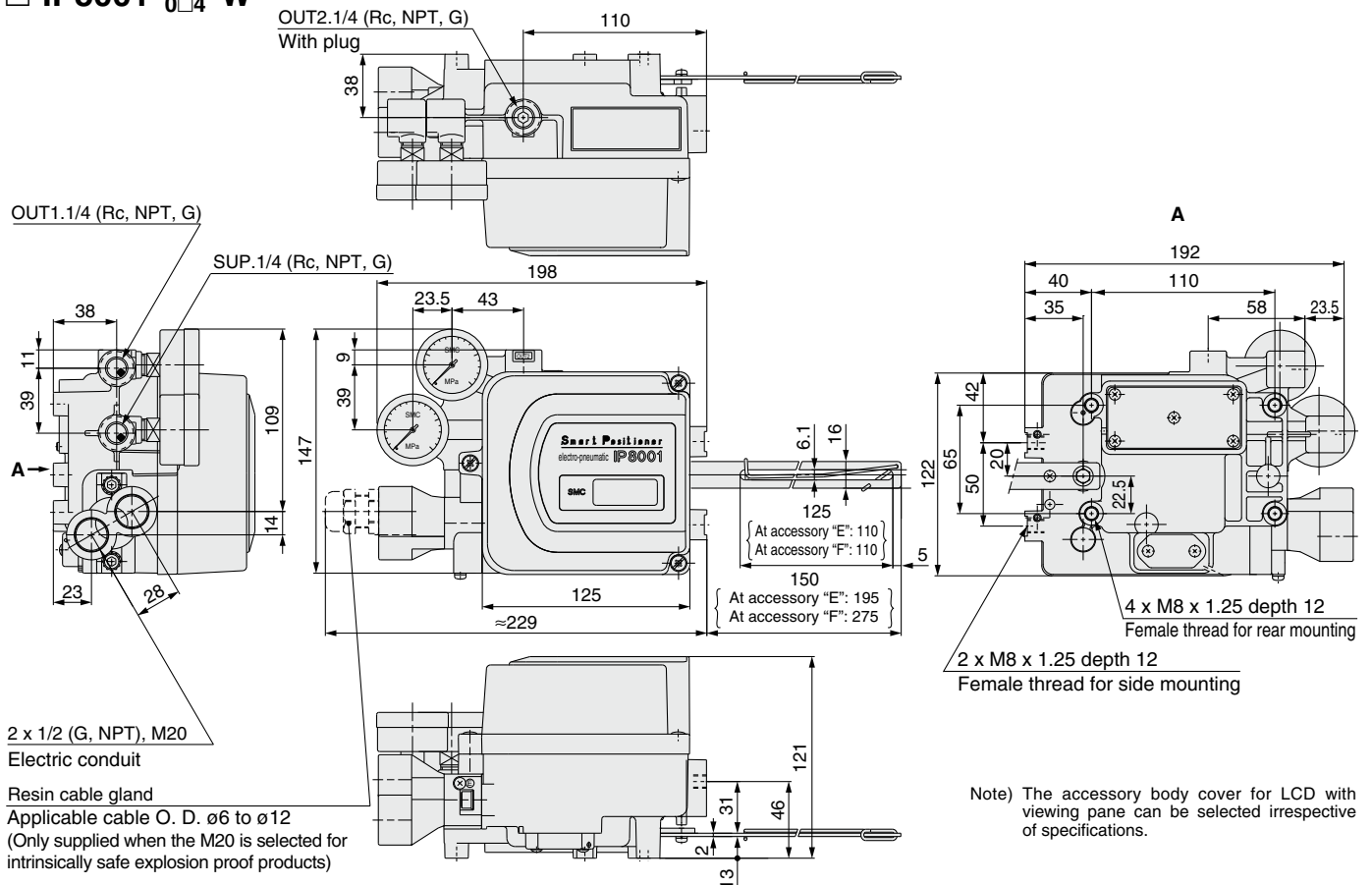

Dimensions/IP8101 (Rotary type)

IP8101-0□0
0□3-W

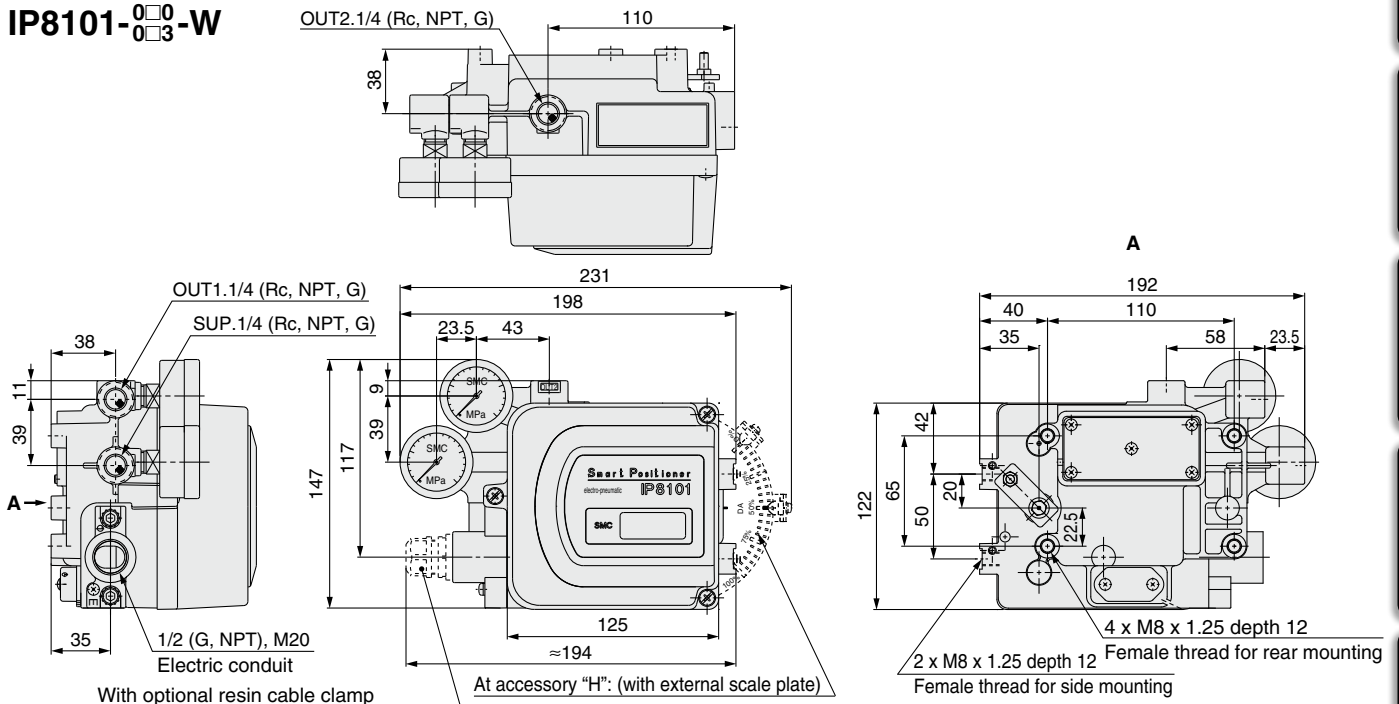

With optional resin cable clamp
Applicable cable O. D. $\phi 7$ to $\phi 9$: P368010-26
Applicable cable O. D. $\phi 9.1$ to $\phi 11$: P368010-27

□-IP8101-0□2
0□4

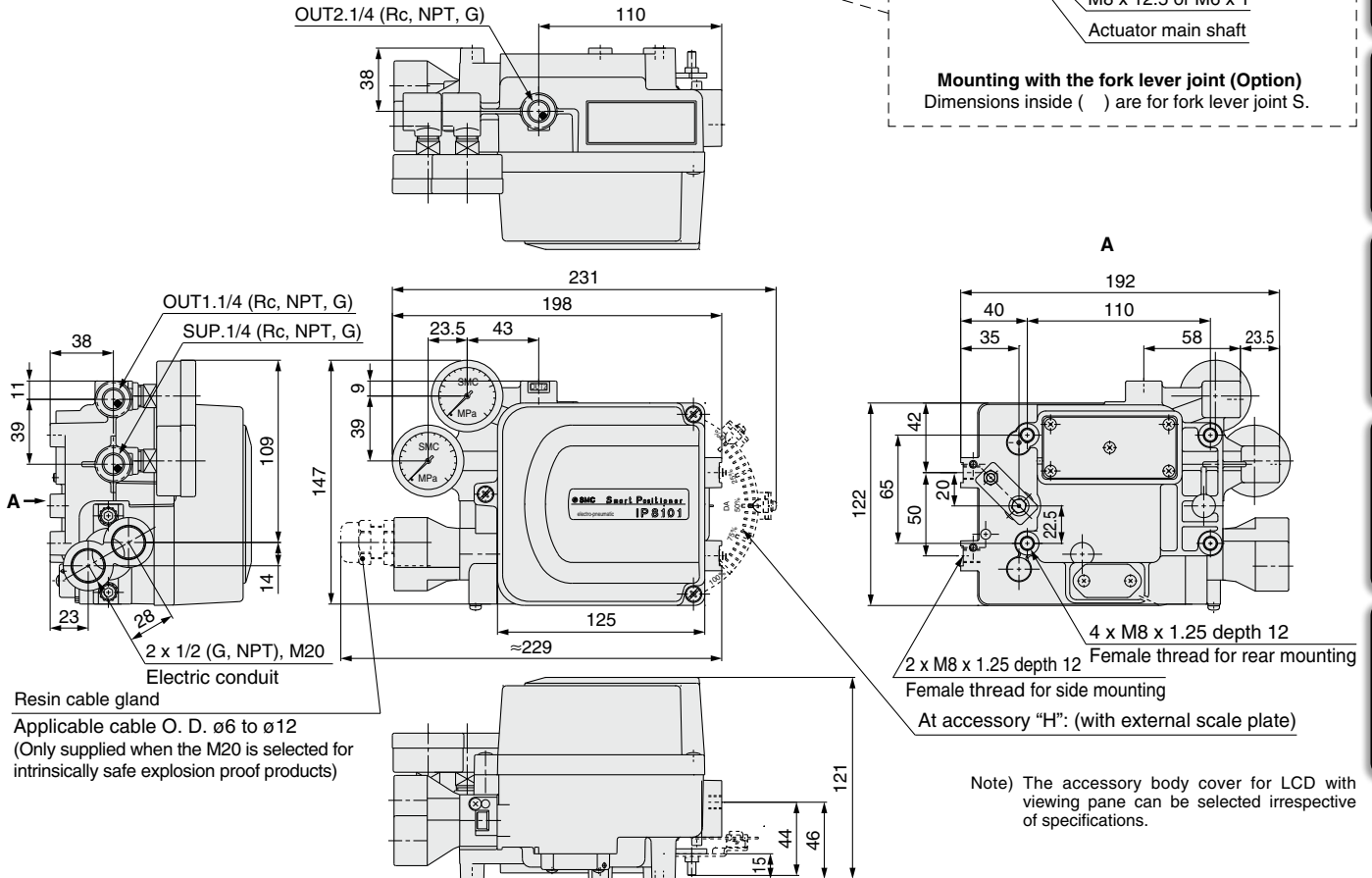

Note) The accessory body cover for LCD with viewing pane can be selected irrespective of specifications.

- Positioners
- Regulators
- Relays/Valves
- Electro-Pneumatic Transducers
- Actuators
- Detection Conversion Unit
- Solenoid Valves
- Air Preparation Equipment
- Industrial Filters
- Piping Materials

Electro-Pneumatic Positioner (Lever type/Rotary type) Made to Order

Please contact SMC for detailed dimensions, specifications, and lead times.



1 Exterior Covering Enclosure: JISF8007 IP66 (Conforms to IEC60529)

* Same as the standard, other than the IP66 compliant protective cover.

How to Order

IP8000/Lever type

IP8000-0 - - - **X310** - **P** -

Lever type
Pressure gauge (SUP, OUT1)
Construction
Accessories
Connection^{Note 2)}
CE marking

Pressure gauge (SUP, OUT1)		Construction		Accessories		Connection ^{Note 2)}		CE marking		
0	None	0	No terminal box (With non-explosive proof connector)	Nil	None (With standard lever)	Nil	Air	Electric	Nil	—
1	0.2 MPa	1	With terminal box (Exd II BT5)	A	∅0.7 Output restriction with pilot valve	M	Rc1/4	G1/2	Q	CE marked product
2	0.3 MPa			B	∅1.0 Output restriction with pilot valve	N	Rc1/4	1/2NPT		
3	1.0 MPa			E	For stroke 35 to 100 mm with lever unit (Standard lever is not attached.)	1	1/4NPT	G1/2		
		F	For stroke 50 to 140 mm with lever unit (Standard lever is not attached.)	2	1/4NPT	M20 x 1.5				
		G	Compensation spring (A) (It is mounted to the body as a replacement of the standard compensation spring.)	3	1/4NPT	1/2NPT				
				4	G1/4	G1/2				
				5	G1/4	M20 x 1.5				
				6	G1/4	1/2NPT				

Note 1) If two or more accessories are required, the part numbers should be given in alphabetical order.
 Note 2) If 1 is selected for Construction, M, N, 2, 3, 5, 6 cannot be selected for Connection.

IP8100/Rotary type

IP8100-0 - - - **X310** - **P** -

Rotary type
Pressure gauge (SUP, OUT1)
Construction
Accessories
Connection^{Note 2)}
CE marking

Pressure gauge (SUP, OUT1)		Construction		Accessories		Connection ^{Note 2)}		CE marking		
0	None	0	No terminal box (With non-explosive proof connector)	Nil	None (With standard lever)	Nil	Air	Electric	Nil	—
1	0.2 MPa	1	With terminal box (Exd II BT5)	A	∅0.7 Output restriction with pilot valve	M	Rc1/4	G1/2	Q	CE marked product
2	0.3 MPa			B	∅1.0 Output restriction with pilot valve	N	Rc1/4	1/2NPT		
3	1.0 MPa			C	Fork lever assembly M	1	1/4NPT	G1/2		
		D	Fork lever assembly S	2	1/4NPT	M20 x 1.5				
		G	Compensation spring (A) (It is mounted to the body as a replacement of the standard compensation spring.)	3	1/4NPT	1/2NPT				
				4	G1/4	G1/2				
				H	With external scale plate	5	G1/4	M20 x 1.5		
				J	With opening current transmission (4 to 20 mA DC, with terminal box, non-explosion proof)/Positive operation	6	G1/4	1/2NPT		
				JR	With opening current transmission (4 to 20 mA DC, with terminal box, non-explosion proof)/Reverse operation					

Note 1) If two or more accessories are required, the part numbers should be given in alphabetical order.
 Note 2) Symbol J/JR is with terminal box, non-explosion proof specification. Select 1 for Construction.
 Note 3) If 1 is selected for Construction, M, N, 2, 3, 5, 6 cannot be selected for Connection.

Dimensions

P8000-X310-P

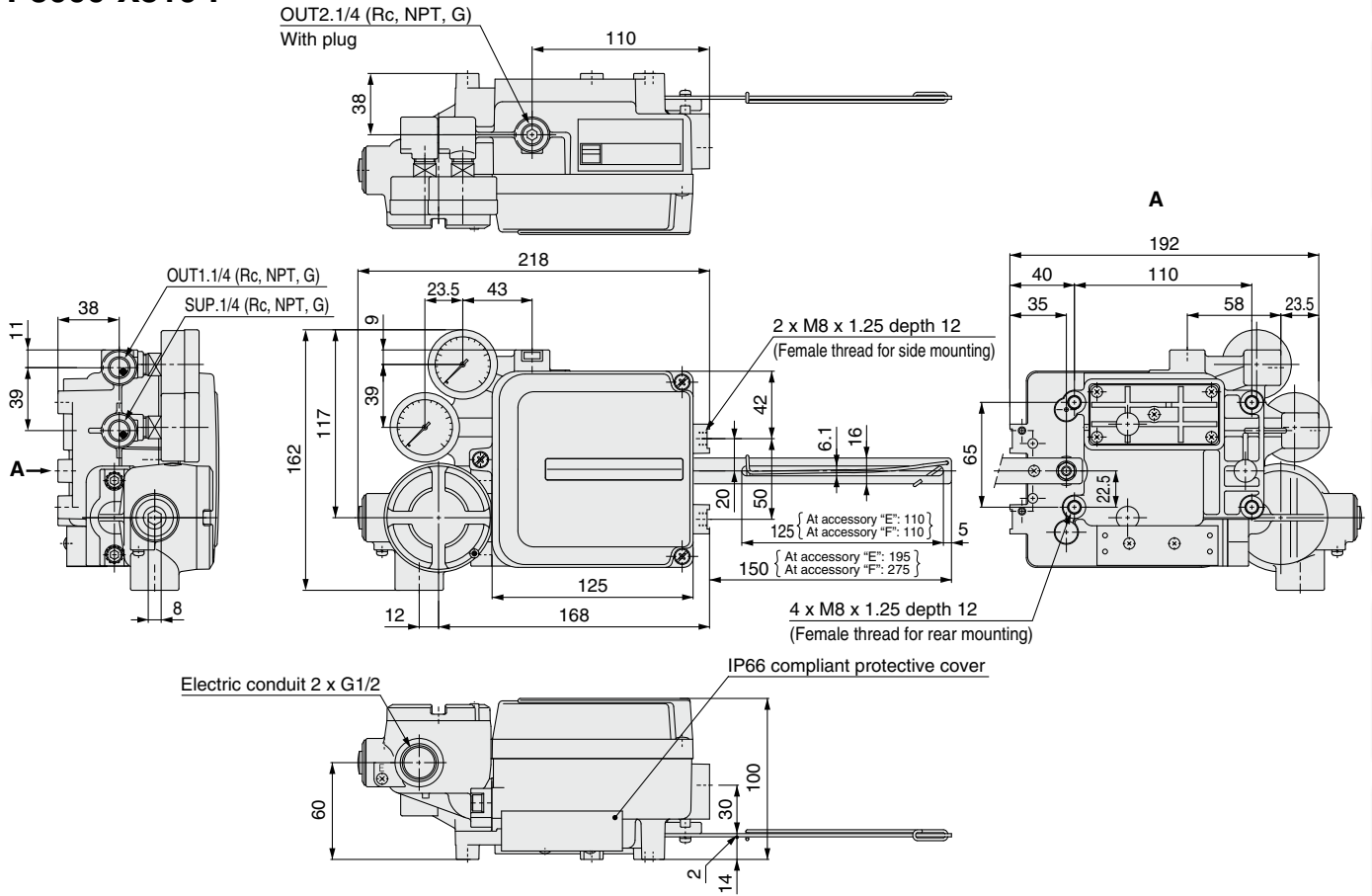

IP8100-X310-P

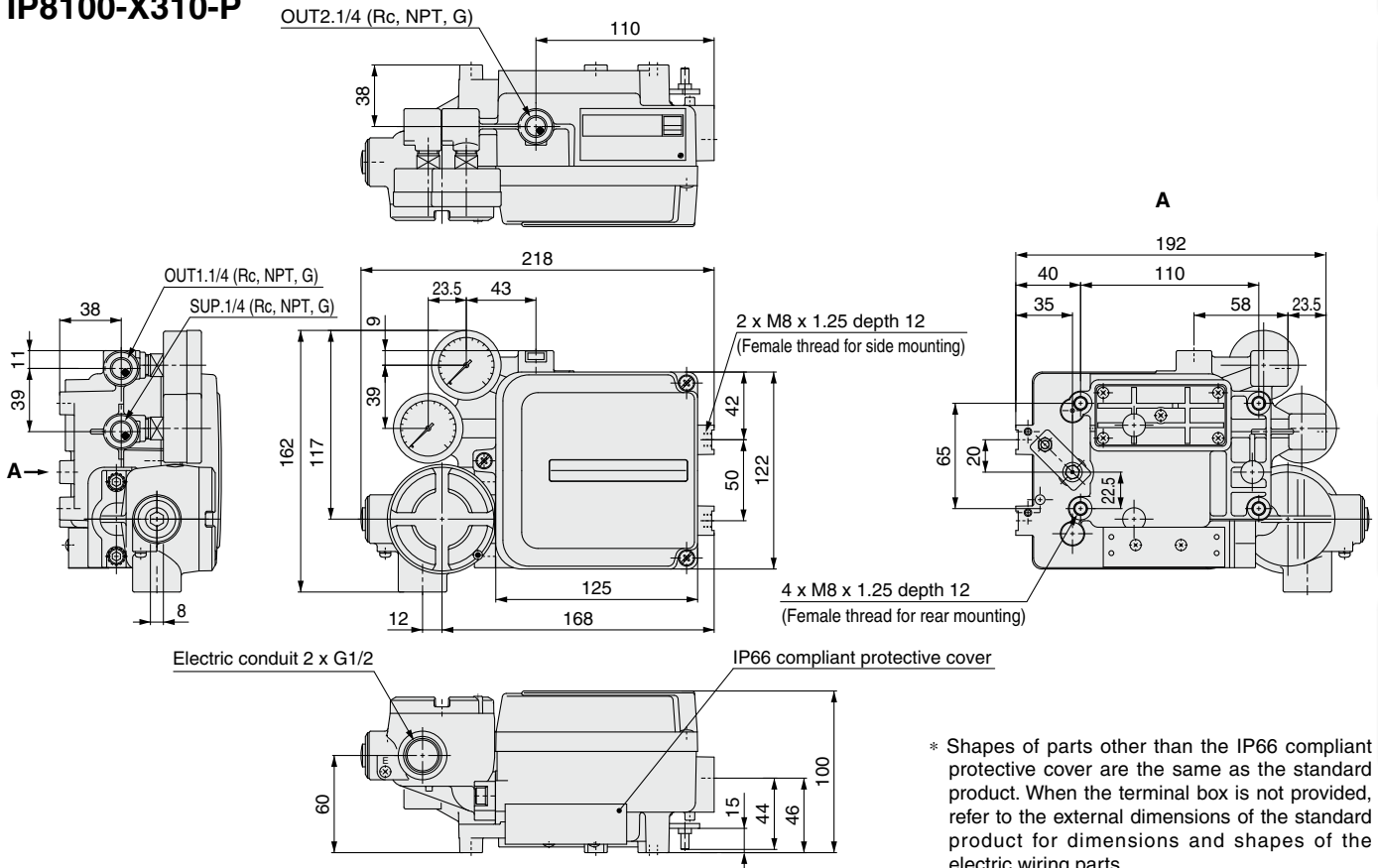

* Shapes of parts other than the IP66 compliant protective cover are the same as the standard product. When the terminal box is not provided, refer to the external dimensions of the standard product for dimensions and shapes of the electric wiring parts.

- Positioners
- Regulators
- Relays/Valves
- Electro-Pneumatic Transducers
- Actuators
- Detection Conversion Unit
- Solenoid Valves
- Air Preparation Equipment
- Industrial Filters
- Piping Materials

2 Exterior Covering Enclosure: JISF8007 IP66 (Conforms to IEC60529)

* Same as the standard, other than the IP66 compliant protective cover.

How to Order

IP8001/Lever type

ATEX directive compliance
 52 ATEX directive category 1

Specifications
 4 Intrinsically safe explosion proof (ATEX) + Output function + HART transmission

ATEX temperature

Nil	T4
T6	T5/T6

52 - IP8001 - 0 **4** - - - - **X405 - P**
IP8001 - 0 - - - **X405 - P** -

Smart lever type

Pressure gauge	Specifications	Accessories	Connection	CE marking
1 0.2 MPa	0 Basic type	Nil None (With standard lever)	Nil Air Electric	Nil —
2 0.3 MPa	2 With output function {Analog (4 to 20 mA DC) output + Alarm output × 2}	E For stroke 35 to 100 mm with lever unit (Standard lever is not attached.)	Nil Rc1/4 G1/2	Q CE marked product
3 1.0 MPa	3 With HART transmission function	F For stroke 50 to 140 mm with lever unit (Standard lever is not attached.)	M Rc1/4 M20 x 1.5	
		W Body with LCD window	N Rc1/4 1/2NPT	
			1 1/4NPT G1/2	
			2 1/4NPT M20 x 1.5	
			3 1/4NPT 1/2NPT	
			4 G1/4 G1/2	
			5 G1/4 M20 x 1.5	
			6 G1/4 1/2NPT	

Note 1) If two or more accessories are required, the part numbers should be given in alphabetical order.
 Note 2) If a connecting port is M20 × 1.5, a blue cable gland is included.

IP8101/Rotary type

ATEX directive compliance
 52 ATEX directive category 1

Specifications
 4 Intrinsically safe explosion proof (ATEX) + Output function + HART transmission

ATEX temperature

Nil	T4
T6	T5/T6

52 - IP8101 - 0 3 **4** - - - - **X405 - P**
IP8101 - 0 3 - - - **X405 - P** -

Smart rotary type

Pressure gauge	Specifications	Accessories	Connection	CE marking
3 1.0 MPa	0 Basic type	Nil None (Standard)	Nil Air Electric	Nil —
	2 With output function {Analog (4 to 20 mA DC) output + Alarm output × 2}	C Fork lever-type fitting M	Nil Rc1/4 G1/2	Q CE marked product
	3 With HART transmission function	D Fork lever-type fitting S	M Rc1/4 M20 x 1.5	
		H With external scale plate	N Rc1/4 1/2NPT	
		W Body with LCD window	1 1/4NPT G1/2	
			2 1/4NPT M20 x 1.5	
			3 1/4NPT 1/2NPT	
			4 G1/4 G1/2	
			5 G1/4 M20 x 1.5	
			6 G1/4 1/2NPT	

Note 1) If two or more accessories are required, the part numbers should be given in alphabetical order.
 Note 2) If a connecting port is M20 × 1.5, a blue cable gland is included.

Dimensions

IP8001-X405-P

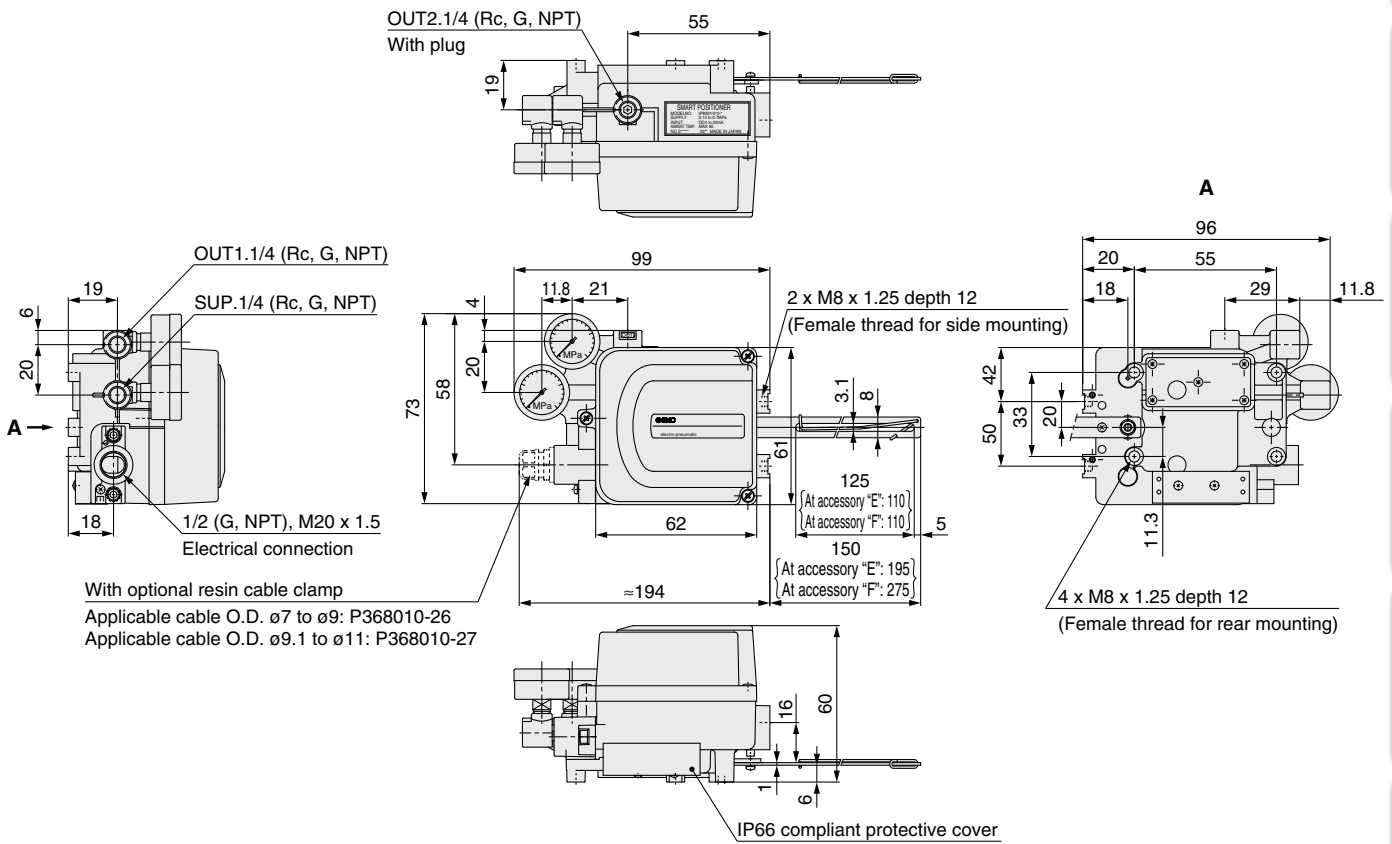

IP8101-X405-P

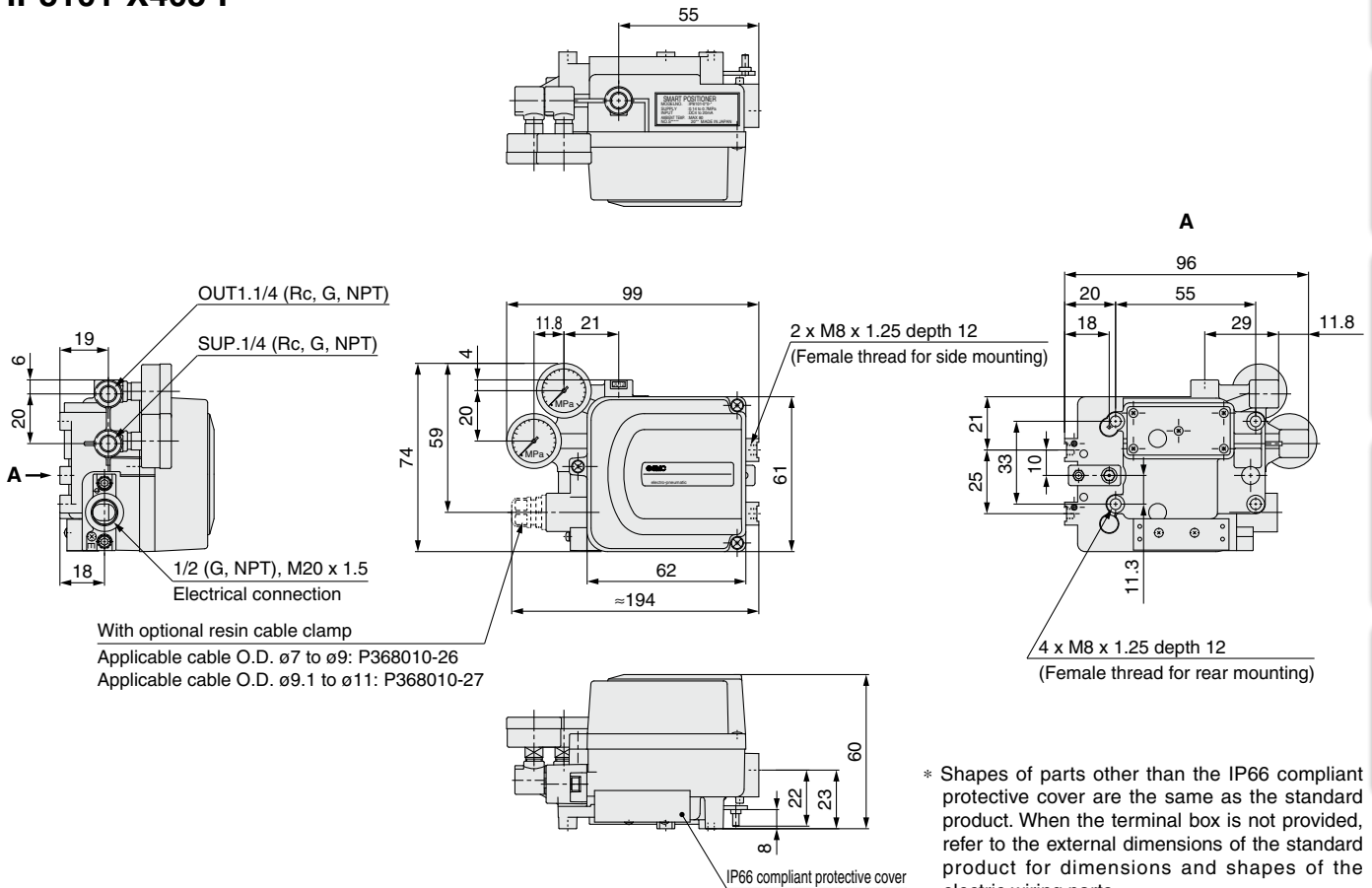

* Shapes of parts other than the IP66 compliant protective cover are the same as the standard product. When the terminal box is not provided, refer to the external dimensions of the standard product for dimensions and shapes of the electric wiring parts.

Technical data

Explosion proof

1. TIIS explosion-proof construction

The electro-pneumatic positioner IP8000/8100 becomes explosion proof, as certified by TIIS, according to the model selected. The explosion-proof grade has the following approval: Exd II BT5.

Take extra care when handling the positioner as explosion-proof equipment

To use as Exd II BT5

A) Pressure-proof packing

As shown below in the chart, use "Cable gland" (Option).

B) Metal piping

Attach the sealant fitting bracket near the cable port.

(For details, refer to "The guideline on electric equipment explosion proof" published by the Technology Institution of Industrial Safety).

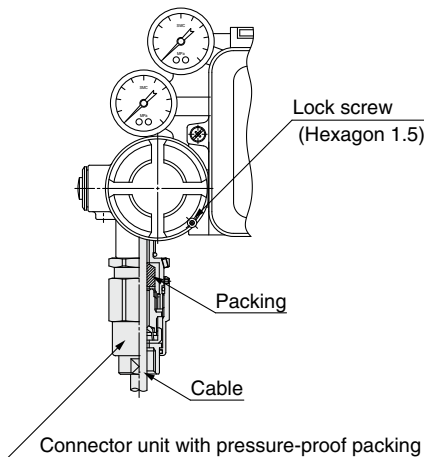

Cable gland with pressure proof packing (Option)

Description	Unit product no.	Applicable outside diameter
Connector unit with pressure proof packing	P368010-32	ø7.0 to ø10.0
	P368010-33	ø10.1 to ø12.0

2. ATEX Intrinsically safe explosion-proof construction

Pneumatic positioners IP8000/8100 and IP8001/8101 Smart Positioners are ATEX compliant, intrinsically safe and explosion proof, as certified by KEMA, the accreditation body for explosion-proof products. Take extra care when handling these explosion-proof products.

In regards to explosion-proof grades,

The Pneumatic Positioner IP8□00 meets II 2G Ex ib II CT5/T6, and

The Smart Positioner IP8□01 meets the II 1G Ex ia II CT4/T5/T6.

Check the positioner's specifications and explosion-proof grades and use in the most optimal environment.

• Wiring

When using the positioner as an intrinsically safe explosion-proof product, always set up a barrier in a **safe environment**, and perform each positioner's wiring through the barrier. Simultaneously, use the provided cable gland (M20 x 1.5) as the extension for the lead wire. If a connecting port other than M20 x 1.5 is selected, the cable gland will not be provided, so use a cable gland with the same or greater explosion-proof grades than this positioner.

• Barrier

Connect the barrier as shown in the diagram below. Moreover, the user must select a barrier that is suitable for each function, based on the ATEX intrinsically safe explosion-proof parameters (current circuit). For IP8001/8101 type smart positioners, use a linear resistant type barrier that is based on the explosion-proof parameters.

Barrier connection diagram

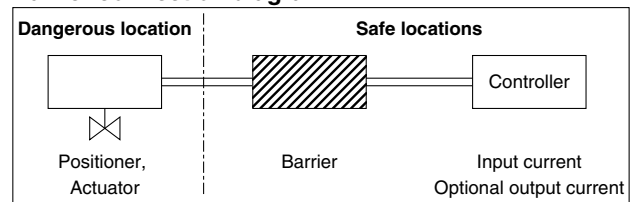

Moreover, at SMC, the barriers listed in the chart below are used to check operations. To purchase, please contact PEPPER + FUCHS Inc. (Germany).

Recommended barriers

	Manufacturer	Model	Note	Applicable model	
				IP8□00-X14	52-IP8□01
For input signal (non HART transmission)	PEPPERL + FUCHS (Germany)	KFD2-CD-Ex1.32	—	○	○
For input signal (for HART transmission)		KFD2-SCD-Ex1.LK KCD2-SCD-Ex1	—	—	○
For analog output		KFD2-STC4-Ex1	—	—	○
For alarm output		KFD2-SOT2-Ex2	Transistor Output passive type	—	○
		KFD2-ST2-Ex2	Transistor Output passive type	—	○
		KFD2-SR2-Ex2.W	Relay output	—	○

HART transmission

With smart positioners IP8001/8101, the user can operate the positioner using buttons and change parameter settings by viewing the LCD display (shown the right). Furthermore, depending on the model selected, the same button operation and parameter settings, and monitoring is possible from a remote location via HART transmission.

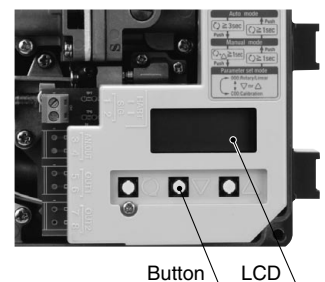

The table below lists an example of applications that are compatible with smart positioner IP8001/8101. Application selection must be made by the user. Please contact Emerson Process Management for further details.

HART transmission compatible application

Product name ^{Note)}	Manufacturer
AMS™ Suite : Intelligent Device Manager®	Emerson Process Management (US)
375 Field Communicator	

Note) AMS™ Suite: Intelligent Device Manager® is a registered trademark of Emerson Electric Co.



Series IP8□

Electro-Pneumatic Positioner/Smart Positioner Specific Product Precautions 1

Be sure to read this before handling.

Operation

⚠ Warning

1. Do not operate the positioner outside the specified range as this may cause problems. (Refer to the specifications.)
2. Design the system to include a safety circuit to avoid the risk of danger should the positioner suffer failure.
3. Be sure that exterior lead-in wiring to the terminal box is based on the guidelines for explosion-protection of manufactory electric equipment when being used as a flame proof, explosion proof construction.
4. Do not remove terminal cover in a hazardous location while the power is on.
5. Covers for the terminal and body should be in place while operating.
6. When using as an intrinsically safe explosion-proof product, do not wire in a hazardous location while the power is on.

⚠ Caution

1. Do not touch the actuator or valve's oscillating section when supply pressure has been added, as this is dangerous.
2. Make sure fingers do not get caught when mounting and aligning the cam.
Cut off the pressure supply and always release the compressed air inside the positioner and actuator before performing this work.
3. Always use with the body cover unit mounted.
Moreover, the positioner may not meet degrees of protection IP65 depending on the body cover mounting conditions. In order to meet degrees of protection IP65, tighten threads using the proper tightening torques (2.8 to 3.0 N·m).
4. Always flush the pipe's insides before piping to ensure foreign objects such as machining chips do not enter the positioner.
5. The actuator opening may become unstable when using the booster relay.
6. Always use a ground connection to prevent noise from the input current and to prevent damage because of static electricity.
7. Use the pressure reading on the supplied pressure gauge as an indication.
8. The supplied pressure gauge's needle will malfunction if the pressure supply to the internal mechanism or positioner freezes.

Ensure that the pressure gauge's internal parts do not freeze if using the pressure gauge in an operating environment with an ambient temperature of less than 0°C.

9. This positioner performs the fixed position control.

Avoid turning ON or OFF the input signal highly frequently.

For Users

⚠ Caution

1. Assemble, operate and maintain the positioners after reading the operation manual thoroughly and understanding the content.

Handling

⚠ Caution

1. Avoid excessive vibration or impact to the positioner body and any excessive force to the armature, as these actions may cause damage to the product. Handle carefully while transporting and operating.
2. If being used in a place where vibration occurs, using a binding band is recommended to prevent broken wires because of the vibration.
3. When exposed to possible moisture invasion, please take the necessary measures. For example, if the positioner is left on-site for long periods, a plug should be put in the piping port and a body cover unit fitted to avoid water penetration.
Take measures to avoid dew condensation inside the positioner if exposed to high temperature and humidity. Take enough measures against condensation especially when packing for export.
4. Keep magnetic field off the positioner, as this affects its characteristics.

Air Supply

⚠ Caution

1. Use only dehumidified and dust extracted clean compressed air as the air supply.
2. Use only dehumidified and dust-extracted clean compressed clean air as the positioner contains extra-fine orifices such as restrictor and nozzle. Do not use a lubricator.
3. Do not use compressed air containing chemicals, organic solvents, salinity or corrosive gases, as this may cause malfunction.
4. When operating below the freezing point, protect the positioner from freezing.

Positioners

Regulators

Relays/Valves

Electro-Pneumatic Transducers

Actuators

Detection Conversion Unit

Solenoid Valves

Air Preparation Equipment

Industrial Filters

Piping Materials



Series IP8□

Electro-Pneumatic Positioner/Smart Positioner Specific Product Precautions 2

Be sure to read this before handling.

Operating Environment

⚠ Caution

1. Do not operate in locations with an atmosphere of corrosive gases, chemicals, sea water, or where these substances will adhere to the regulator.
2. Do not operate out of the indicated operation temperature range as this may cause damage to electronic parts and seal materials to deteriorate.
3. Do not operate in locations where excessive vibration or impact occurs.
4. If the body cover is being installed in a place where the body cover is exposed to direct sunlight, the use of a standard body cover without the LCD window is recommended.

Maintenance

⚠ Warning

1. After installation, repair or disassembly, connect compressed air and conduct tests to confirm appropriate function and leakage.

Do not use the positioner when noise from the bleeder sounds louder compared with the initial state, or when it does not operate normally. If these occur, check immediately if assembled and mounted correctly.

Never modify electrical construction to maintain explosion-proof construction.

⚠ Caution

1. Confirm whether the compressed air is clean.
Dust, oil, or moisture mixed within the equipment may result in malfunction and positioner problems. Perform periodic inspection of the air preparation equipment to ensure clean air is always supplied.
2. Improper handling of compressed air is dangerous. Not only observing the product specifications, but also replacement of elements and other maintenance activities should be conducted by personnel having sufficient knowledge and experience pertaining to instrumentation equipment.
3. Perform annual inspections of the positioner.
Replace badly damaged seals and units such as diaphragm and O-ring during the inspection.
When used in tough environmental and/or service conditions such as seaside locations, replacements should be undertaken more frequently.

Maintenance

⚠ Caution

4. When performing inspections, demounting the positioner, or replacing the elements with the positioner still in its mounted position, first, stop the compressed air, then exhaust the residual pressure before undertaking operation.
5. Should the restrictor become clogged with carbon particles, etc., demount automatic/manual change-over screw (with built-in restrictor) and clean it using a $\varnothing 0.2$ wire.
Stop the compressed air and remove the screw to switch the pilot valve off before replacing the restrictor.
6. Apply just a small amount of grease set by SMC to the sliding parts (O-ring and exhaust valve) when disassembling a pilot valve unit.
Replacing the valve unit every three years is recommended.
7. Check for air leakage from pipes that pass compressed air and connecting parts.

Air leakage from air piping results in reduced operational performance and a decline of characteristics, etc.

It is structurally necessary for air to be released from the bleeder, it is not abnormal as long as the air consumption is within the specified range.

Pneumatic-Pneumatic Positioner (Lever type/Rotary type)

Series IP5000/5100

- JIS F8007 IP55
- Fulfilling options: Opening indicator (IP5100), Built-in bypass (SIG-OUT1) (IP5000), Built-in equalizing valve (OUT1-OUT2) (IP5100)

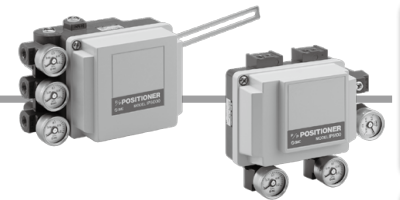

How to Order

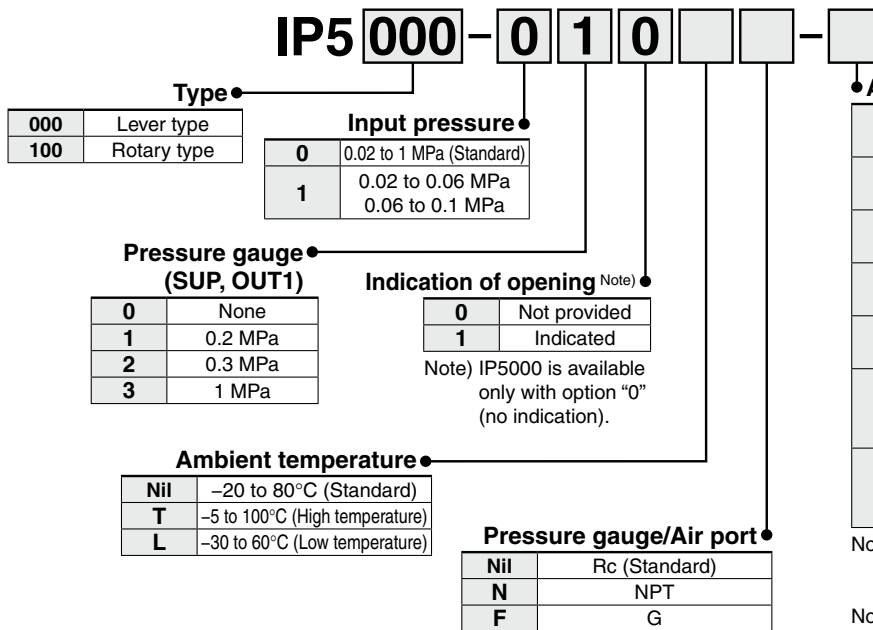

Accessories (Note 1)

Nil	None (Standard)	With standard lever (10 to 85 mm stroke) for IP5000
A	ø0.7 Output restriction with pilot valve	Common to IP5000 and IP5100 small capacity actuators
B	ø1.0 Output restriction with pilot valve	
C	Fork lever-type fitting M	Only for IP5100
D	Fork lever-type fitting S	
E	For stroke 35 to 100 mm with lever unit	Only for IP5000 (Note 2)
F	For stroke 50 to 140 mm with lever unit	

Note 1) If two or more accessories are required, the part numbers should be given in alphabetical order. Ex.) IP5000-010-AD

Note 2) For "E" and "F", standard lever is not provided.

Specifications

Item	Type	IP5000		IP5100	
		Lever type lever feedback		Rotary type cam feedback	
		Single action	Double action	Single action	Double action
Supply pressure		0.14 to 0.7 MPa			
Input pressure		0.02 to 0.1 MPa			
Standard stroke		10 to 85 mm		60° to 100°	
Sensitivity		Within 0.1% F.S.		Within 0.5% F.S.	
Linearity		Within ±1% F.S.		Within ±2% F.S.	
Hysteresis		Within 0.75% F.S.		Within 1% F.S.	
Repeatability		Within ±0.5% F.S.			
Air consumption		5 L/min (ANR) or less (SUP = 0.14 MPa) ^{Note}		11 L/min (ANR) or less (SUP = 0.4 MPa) ^{Note}	
Output flow rate		80 L/min (ANR) or more (SUP = 0.14 MPa) ^{Note}		200 L/min (ANR) or more (SUP = 0.4 MPa) ^{Note}	
Ambient and fluid temperature		-20°C to 80°C (Standard)			
Coefficient of temperature		Within 0.1% F.S./°C			
Air connection port		Rc1/4 (Standard)			
Main component parts		Aluminum die-cast, Stainless steel, Brass, Nitrile rubber			
Weight		Approx. 1.4 kg		Approx. 1.2 kg	
Dimensions		118 x 102 x 86 (Body)		118 x 92 x 77.5 (Body)	

Note) Standard air temperature: 20°C (293 K), Absolute pressure: 760 mmHg (101.3 kPa), Relative humidity: 65%

Replacement Parts

Part no.	Description	Note
P378010-10	Pilot valve unit	For IP5000
P378020-11	Pilot valve unit	For IP5100
P368010-24	Fork lever assembly M	For IP5100 (Accessory: C)
P368010-25	Fork lever assembly S	For IP5100 (Accessory: D)
P378010-11	Feedback lever	For IP5000/10 to 85 mm (Accessory: Nil)
P378010-12	Feedback lever	For IP5000/35 to 100 mm (Accessory: E)
P378010-13	Feedback lever	For IP5000/50 to 140 mm (Accessory: F)

Precautions

1. Avoid impact to positioner while transporting and handling.
2. Operate within specified temperature range to prevent deterioration of seals.
3. Attach a body cover to the positioner when it is in use or left in the field in order to avoid rain water.
4. Take measures to avoid dew condensation if the positioner is exposed to high temperature and humidity during transportation or storage or when it is left on the site.
5. The zero point is subject to the mounting position. Adjust zero point after installation on the site.

Series IP5000/5100

Principle of Operation

IP5000 type

When the input pressure applied to the SIG port of the positioner increases, bellows ① press balance lever ② to the left. As this movement moves flapper ④ to the left through connecting spring ③, the gap between nozzle ⑤ and flapper ④ widens, and the nozzle back pressure of pilot valve ⑥ drops. As a result, the pressure balance in the constant pressure chamber is broken, and exhaust valve ⑬ presses inlet valve B ⑭ to the right, thus opening inlet port B. Then, output pressure OUT1 rises, and driven diaphragm ⑦ moves downward.

The movement of diaphragm valve ⑦ deflects feedback arm ⑪ to the right through feedback lever ⑧, transmission lever ⑨, and roller ⑩. Such deflection increases the tension of feedback spring ⑫ and acts on balance lever ②.

Since driven diaphragm ⑦ moves until the tensile force of feedback spring ⑫ and the force generated by bellows ① balance, it is always set in the position proportional to the input pressure. When the signal air pressure decreases, the operation is reversed.

IP5000 principle of operation

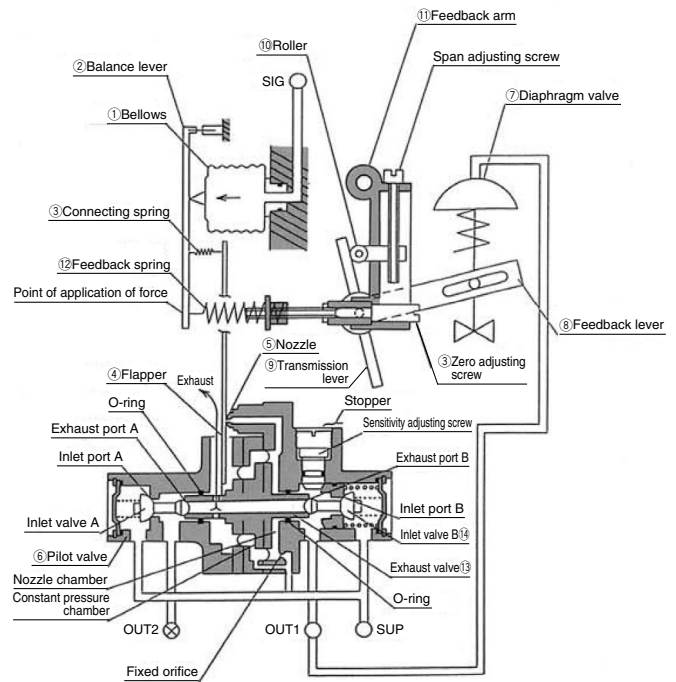

IP5100 type

When the input pressure applied to the SIG port of the positioner increases, bellows ① press balance lever ② to the left. As this movement moves flapper ④ to the left through connecting spring ③, the gap between nozzle ⑤ and flapper ④ widens, and the nozzle back pressure of pilot valve ⑥ drops. As a result, the pressure balance in the constant pressure chamber is broken, and exhaust valve ⑭ presses inlet valve B ⑮ to the right. Then, inlet port B opens, and output pressure OUT1 increases.

In the meantime, the movement of exhaust valve ⑭ to the right opens exhaust port A, and output pressure OUT2 decreases. Therefore, pressure difference is generated between pressure chamber 1 and pressure chamber 2 of oscillating actuator ⑦, and actuator shaft ⑧ turns in the direction of the arrow. The movement of actuator shaft ⑧ deflects feedback arm ⑫ to the right through feedback shaft ⑨, cam ⑩, and bearing ⑪. Such deflection increases the tension of feedback spring ⑬ and acts on balance lever ②.

Since oscillating actuator ⑦ moves until the tensile force of feedback spring ⑬ and the force generated by bellows ① balance, it is always set in the position proportional to the input pressure. When the signal air pressure decreases, the operation is reversed.

IP5100 principle of operation

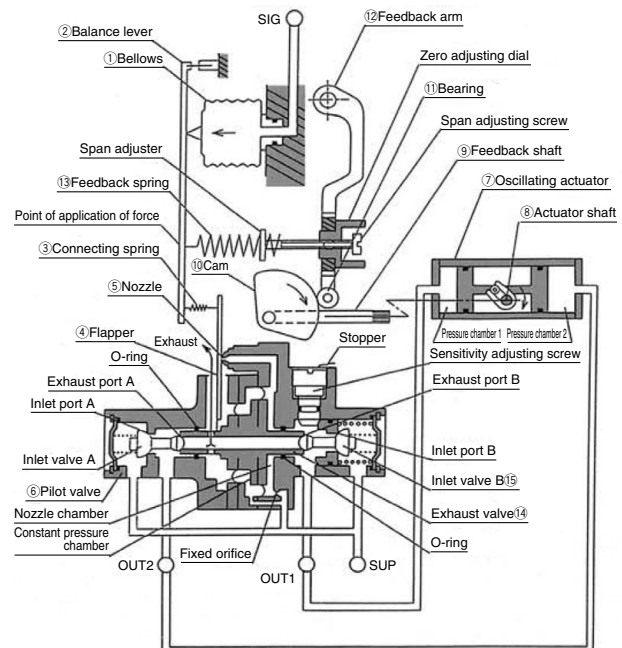

Dimensions

IP5000 type (Lever type lever feedback)

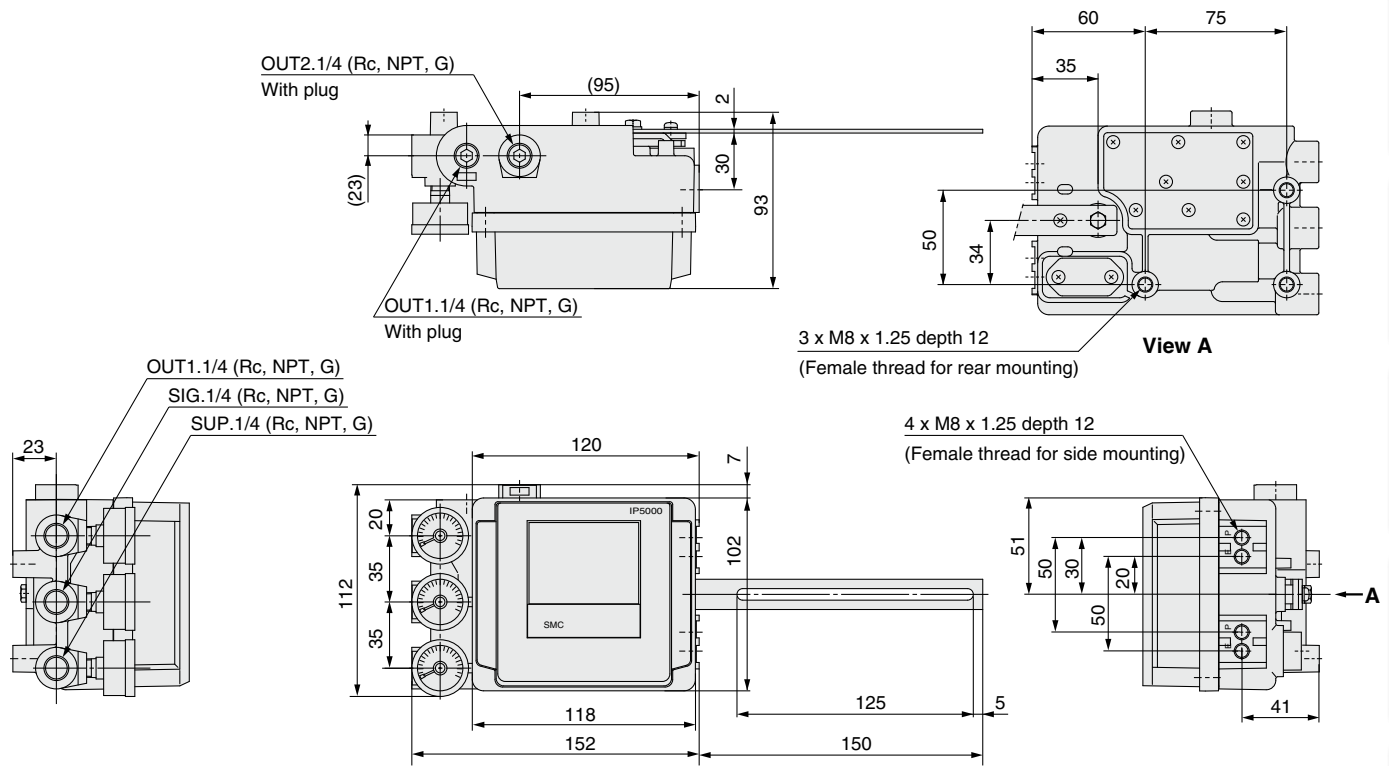

IP5100 type (Rotary type cam feedback)

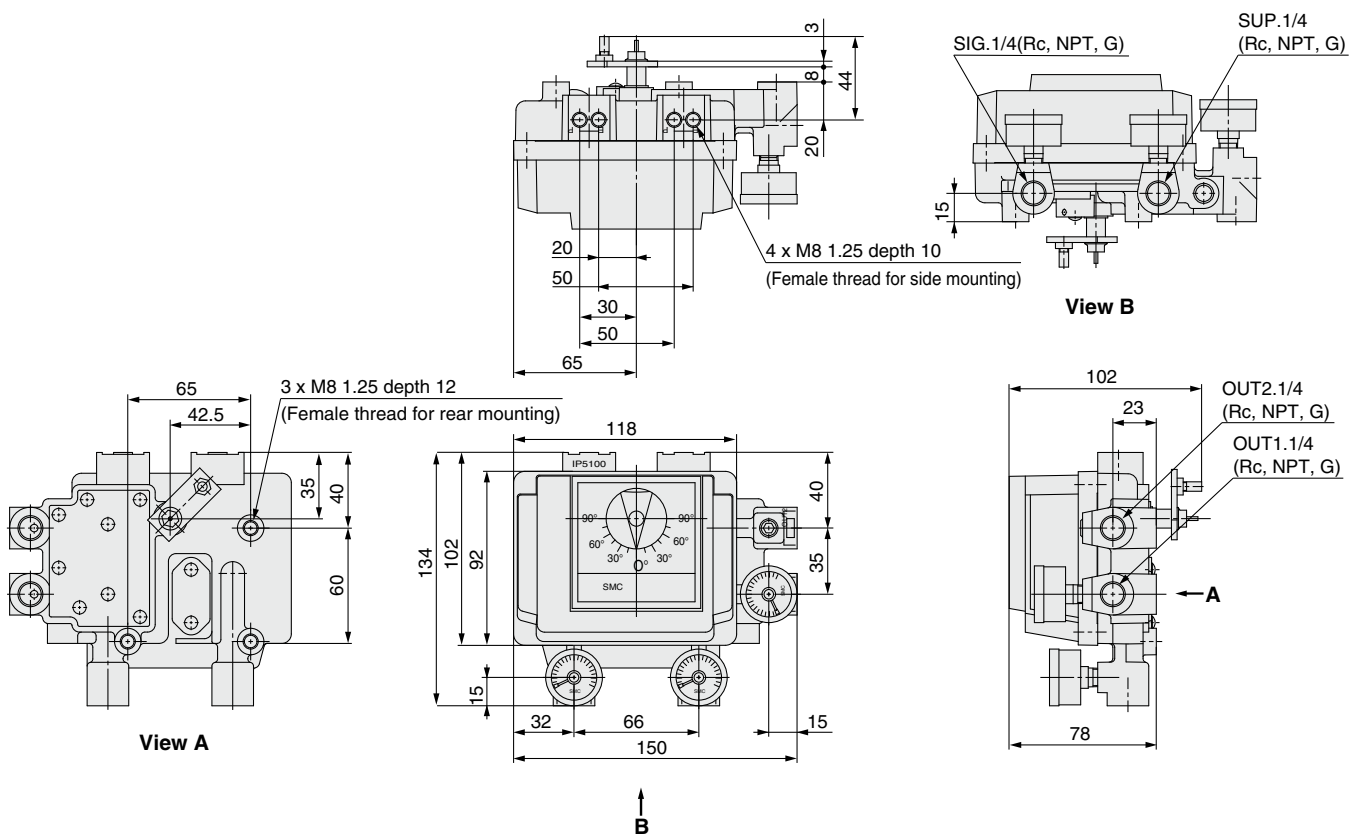

B



- Positioners
- Regulators
- Relays/Valves
- Electro-Pneumatic Transducers
- Actuators
- Detection Conversion Unit
- Solenoid Valves
- Air Preparation Equipment
- Industrial Filters
- Piping Materials

Cylinder Positioner Series IP200

- Servo-mechanism allows precise and stable position control of cylinders.
- Can be used as a cylinder position control unit for general industrial machines.

How to Order

IP200 - 100

• Applicable stroke

25 to 300 mm

* Manufacture of strokes at 1 mm intervals is possible.

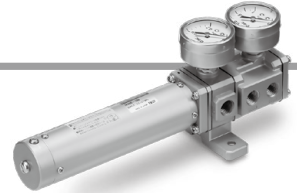

Specifications (No load)

Supply pressure	0.3 to 0.7 MPa
Input pressure	0.02 to 0.1 MPa
Applicable bore size	ø50 or more
Applicable stroke	25 to 300 mm or less
Sensitivity	Within 0.5% F.S.
Linearity	Within ±2% F.S.
Hysteresis	Within 1% F.S.
Repeatability	Within ±1% F.S.
Air consumption*	18 L/min (ANR) or less (SUP = 0.5 MPa)
Influence by change in supply pressure	Within 1% F.S./0.05 MPa
Ambient and fluid temperature	-5°C to 60°C
Port size	Rc1/4 (Gauge port Rc1/8)
Weight	Approx. 700 g

* Air consumption is due to exhaust from nozzle.

Replacement Parts

Part no.	Description	Note
IP200-02	Pilot valve unit	
39020-23	Seal kit	Ambient temperature: Standard (-5° to 60°)

Construction/Principle of Operation

When signal pressure enters input chamber ①, the input diaphragm ③ is deflected left. Clearance of the nozzle ⑥ is reduced causing higher back pressure at diaphragm A ⑦. This diaphragm A ⑦ has larger area than diaphragm B ⑧ resulting in movement of the spool to the left. Supply pressure then flows to OUT1 ① and partial exhaust from OUT2 ② takes place resulting in cylinder rod ⑤ movement to the right. The movement is linked via connecting rod ④ and feedback spring ② to the input diaphragm ③ balancing the higher pressure. When this occurs nozzle ⑥ clearance increases allowing centralizing of the spool ⑨ to take place. This holds the piston rod in the new position. Input signal increase results in proportional movement of the piston rod.

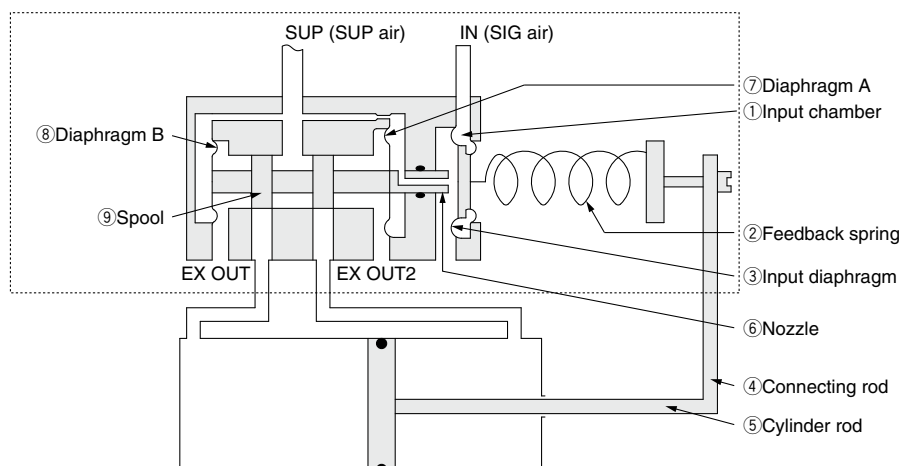

Dimensions

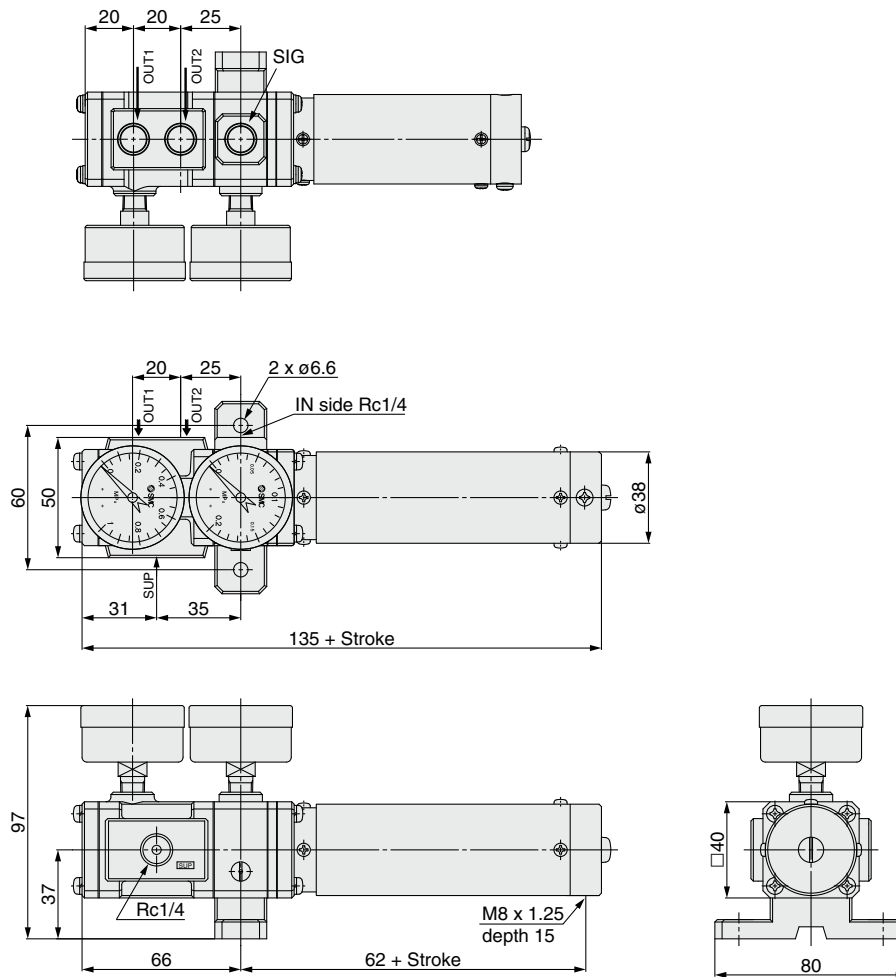

⚠ Precautions

Caution

⚠ Caution

1. Positioner has a restrictor and a nozzle which has fine paths in it. Therefore, use clean air which is dehydrated and filtered, and also avoid employing a lubricator which causes malfunction.
2. Be sure to flush the piping to prevent foreign matter from entering the positioner before connecting them.

Positioners

Regulators

Relays/Valves

Electro-Pneumatic Transducers

Actuators

Detection Conversion Unit

Solenoid Valves

Air Preparation Equipment

Industrial Filters

Piping Materials

Pneumatic Instrumentation Equipment

Regulators



Filter Regulator/IW	Page 38
Filter Regulator/1301	Page 42
Filter Regulator for Low Temperature Environment (−30 to 60°C)/ High Temperature Environment (−5 to 80°C)/ AW-X430/-X440	Page 45
Filter Regulator: Stainless Steel 316 and Special Temperature Environment (−40°C) Specifications/ AW30/40-X2622	Page 47
Precision Regulator/IR	Page 51

Filter Regulator Series IW

- Two types are available: adjustable set pressure type and fixed set pressure type.
- Low/High temperature and external parts copper-free types can be selected.
- Pressure gauge connecting direction: 2 directions (Front/Back)
- Weight: 0.66 kg (Adjustable type), 0.58 kg (Fixed type)



How to Order

IW 2 1 2 - 02 -

Filter regulator

Type of setting

1	Adjustable type (Handle)
2	Fixed type (0.14 MPa)

Set pressure

2	0.02 to 0.2 MPa
3	0.02 to 0.3 MPa
5	0.02 to 0.5 MPa

* Fixed type is IW222 only.

Accessories

Nil	None
B	With bracket
G	With pressure gauge

Port size

02	1/4
----	-----

Thread type

Nil	Rc
N	NPT*

* Semi-standard

Suffix

	Low temperature (-30 to 60°C)	High temperature* (-10 to 100°C)	External parts copper-free
Nil	—	—	—
T	—	●	—
L	●	—	—
S	—	—	●
ST	—	●	●
SL	●	—	●

* With pressure gauge type: Max. 80°C.

Standard Specifications

Model	IW212	IW213	IW215	IW222
	Adjustable type (Basic)			Fixed type
Maximum supply pressure	Max. 1.0 MPa			0.3 to 1.0 MPa
Set pressure	0.02 to 0.2 MPa	0.02 to 0.3 MPa	0.02 to 0.5 MPa	0.14 MPa
Air consumption (At maximum set pressure)	1 L/min (ANR) or less			0.5 L/min (ANR) or less
Ambient and fluid temperature	-10 to 60°C (No freezing)			
Filtration accuracy	5 μm			
Port size	Rc1/4			
Pressure gauge port	Rc1/4 (2 locations)			
Weight	0.66 kg			0.58 kg

Positioners

Regulators

Relays/Valves

Electro-Pneumatic Transducers

Actuators

Detection Conversion Unit

Solenoid Valves

Air Preparation Equipment

Industrial Filters

Piping Materials

Flow-rate Characteristics (Representative values)

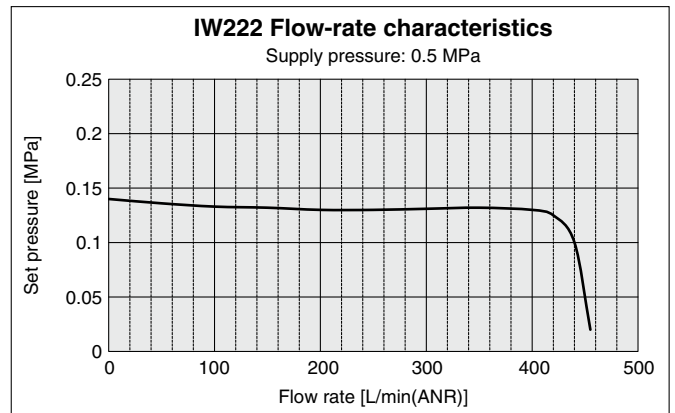
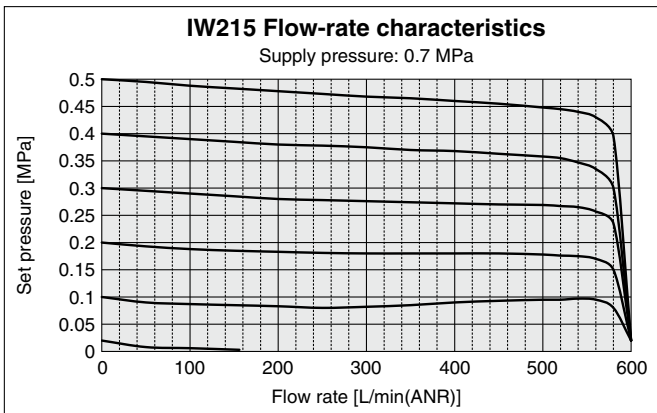
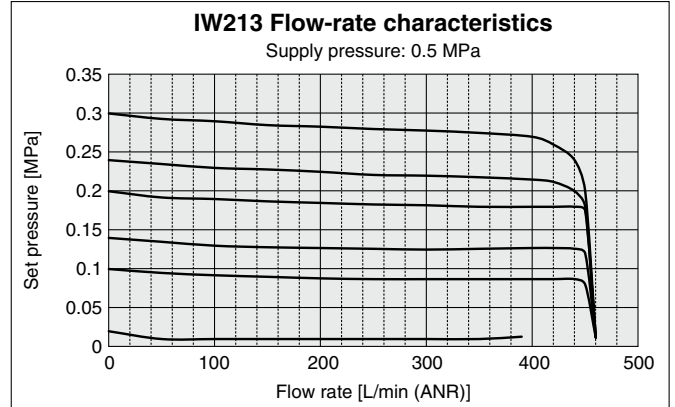
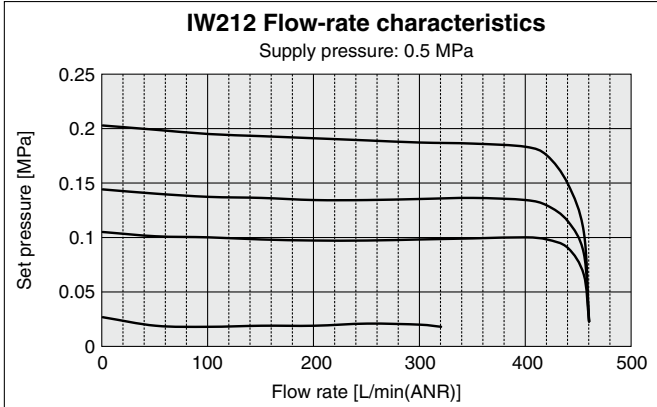

Pressure Characteristics (Representative values)

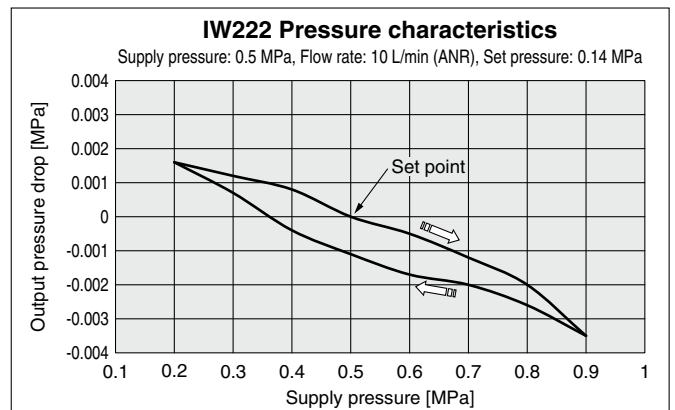
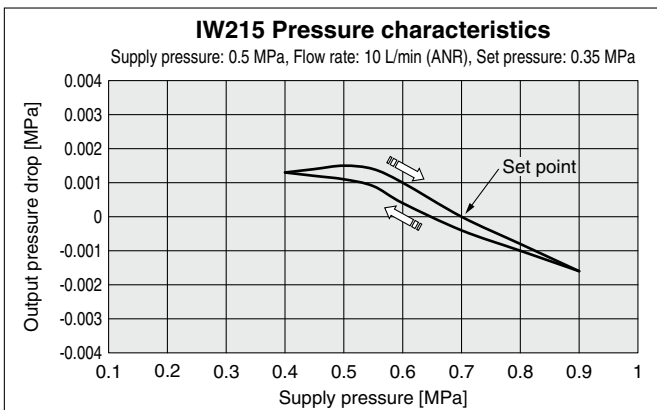
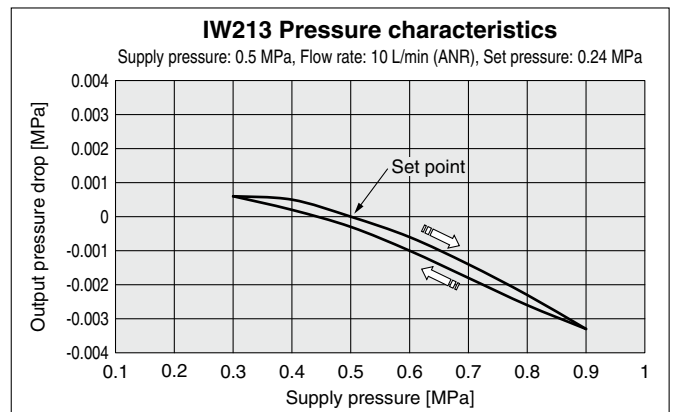
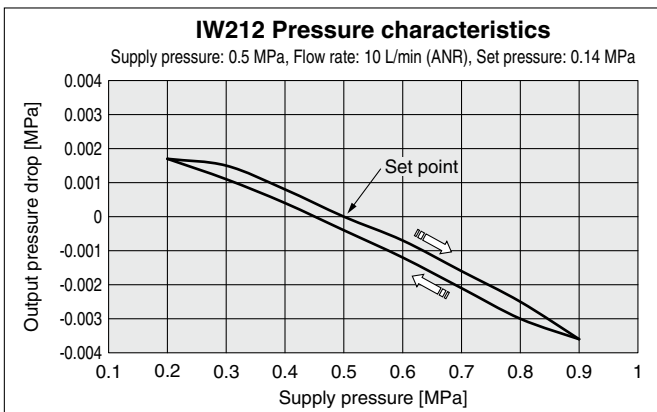

Principle of Operation

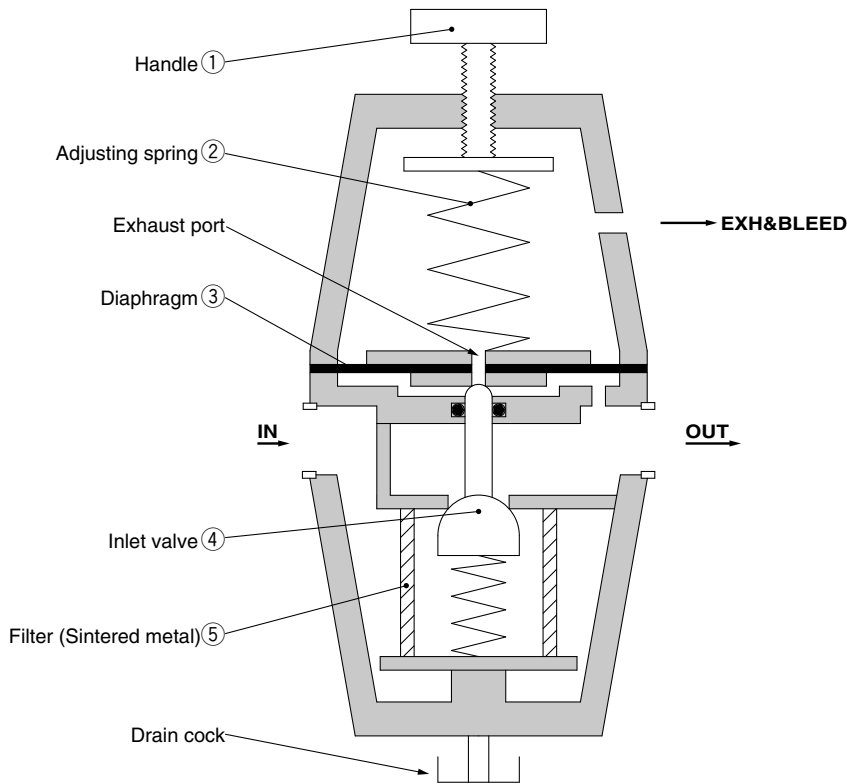

Air flow from the inlet passes through filter (sintered metal) ⑤ where solids are removed. When handle ① is adjusted downwards, adjusting spring ② is compressed. The inlet valve ④ is opened allowing air flow to the outlet. Air outlet pressure balances against diaphragm ③ and adjusting spring ②. When the outlet pressure is higher than the set pressure, the inlet valve ④ is closed and exhaust of the excess outlet pressure takes place through the adjusting spring cover bleed. This ensures constant outlet pressure is maintained.

Construction

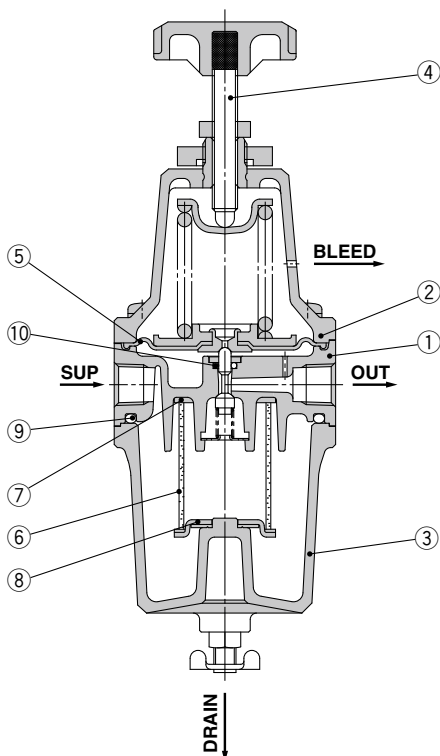

Component Parts

No.	Description	Material	Note
1	Body assembly	Aluminum die-casted/Aluminum	Silver color
2	Bonnet	Aluminum die-casted/Brass	Silver color
3	Bowl assembly	Aluminum die-casted/Brass	Silver color
4	Handle	ABS/Stainless steel	—

Replacement Parts

No.	Description	Material	Part no.
5	Diaphragm assembly	Aluminum die-casted/Brass/NBR	P218010-1
6	Element	Bronze	1301111-5B
7	Seal	NBR	1301510
8	Filter disk assembly	Brass/NBR	P218010-16
9	O-ring	NBR	AS568-228
10	O-ring	NBR	JISB2401 P4

Series IW

Dimensions

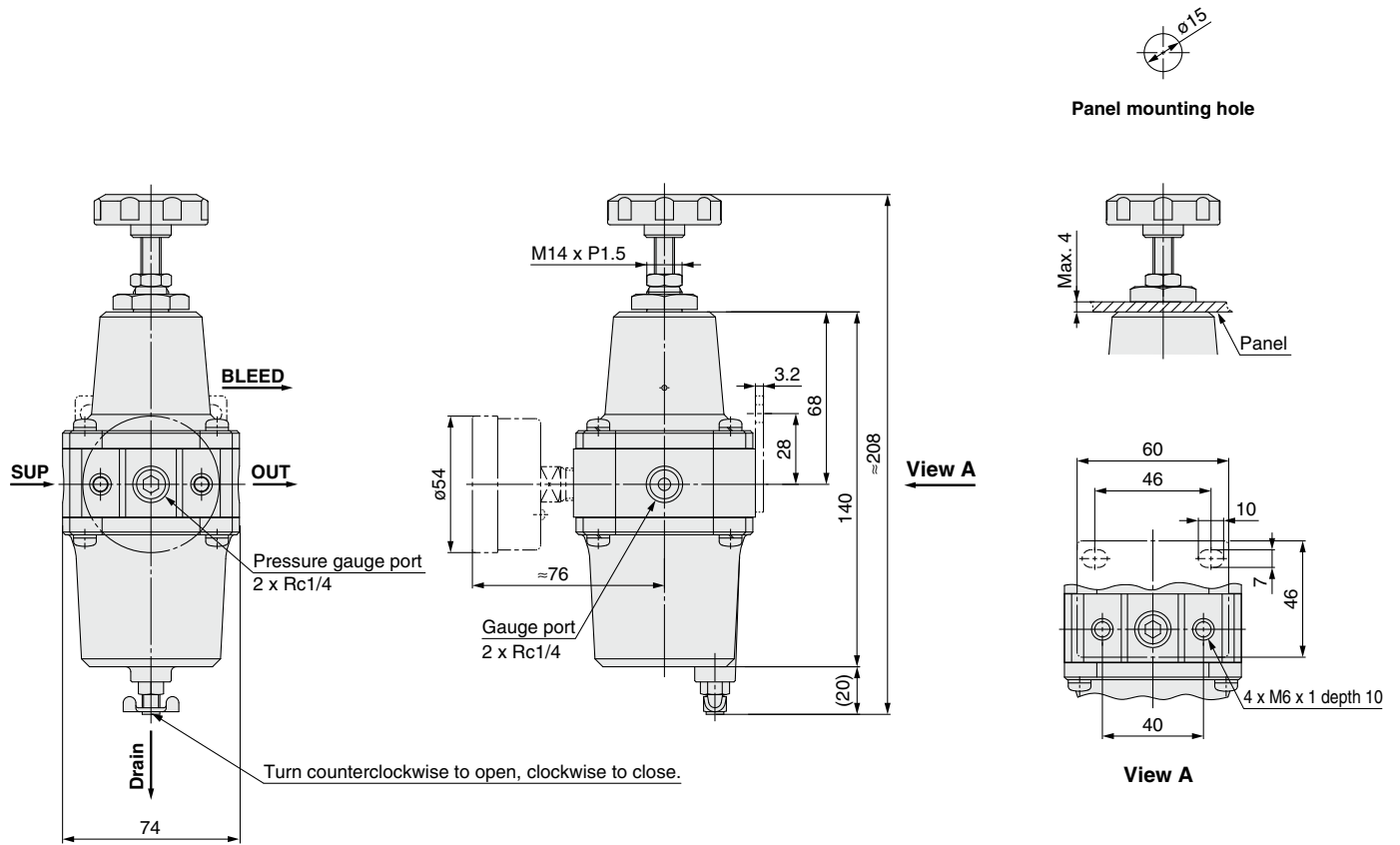

Filter Regulator Series 1301

- External main parts: Stainless steel type is available.
- Low temperature/High temperature type is available.
(Made-to-Order products of Series AW on page 45)



How to Order

1301 - 002

Filter regulator • Accessories •

Set pressure	
002	0.02 to 0.2 MPa
1202	0.02 to 0.29 MPa
2502	0.02 to 0.49 MPa
902*	0.02 to 0.2 MPa

Nil	None
B	With bracket
G	With pressure gauge

* External main parts are made of stainless steel. For details, refer to page 43.

Standard Specifications

Model	Basic type			External main parts: Stainless steel
	1301-002	1301-1202	1301-2502	1301-902
Maximum supply pressure	Max. 1.0 MPa			
Set pressure	0.02 to 0.2 MPa	0.02 to 0.29 MPa	0.02 to 0.49 MPa	0.02 to 0.2 MPa
Ambient and fluid temperature	-5 to 60°C (No freezing)			
Filtration accuracy	5 μm			
Port size	Rc1/4			
Pressure gauge port	Rc1/8 (1 location)			
Weight	1.07 kg			

Flow-rate Characteristics (Representative values)

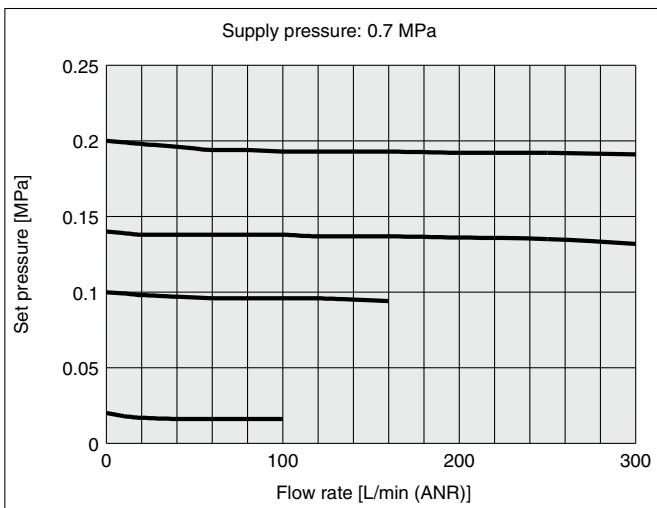

Pressure Characteristics (Representative values)

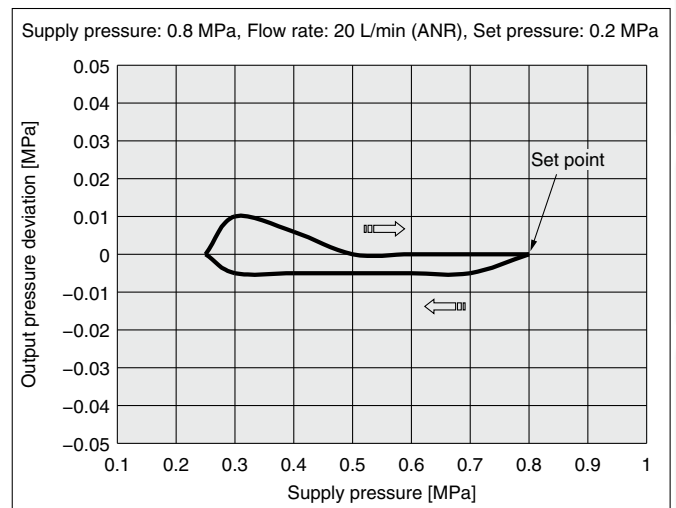

Series 1301

Principle of Operation

1301

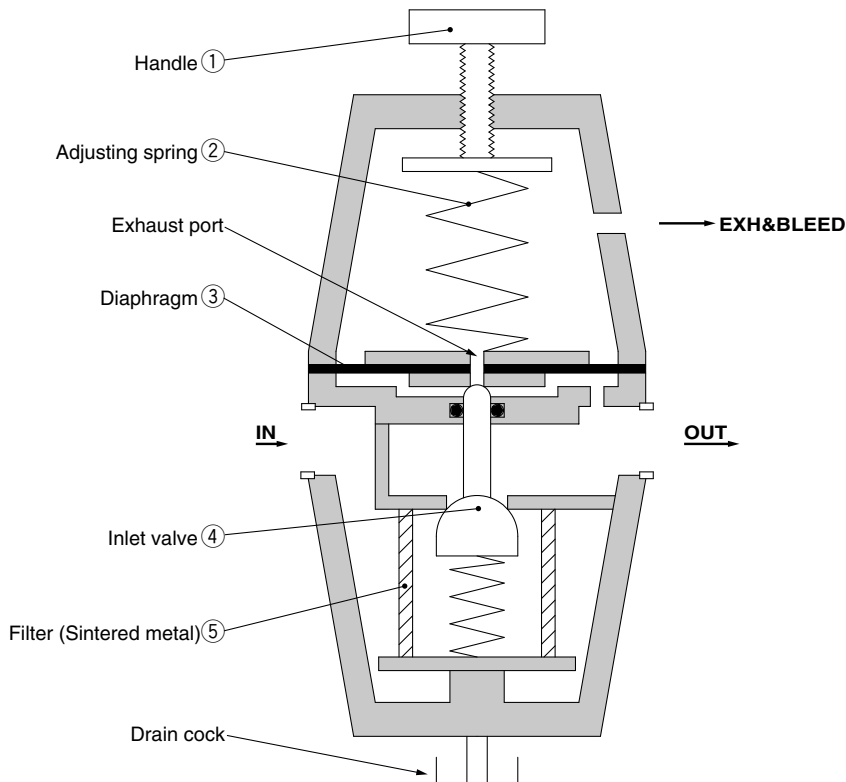

Air flow from the inlet passes through filter (sintered metal) ⑤ where solids are removed. When handle ① is adjusted downwards, adjusting spring ② is compressed. The inlet valve ④ is opened allowing air flow to the outlet. Air outlet pressure balances against diaphragm ③ and adjusting spring ②. When the outlet pressure is higher than the set pressure, the inlet valve ④ is closed and exhaust of the excess outlet pressure takes place through the adjusting spring cover bleed. This ensures constant outlet pressure is maintained.

Construction

1301

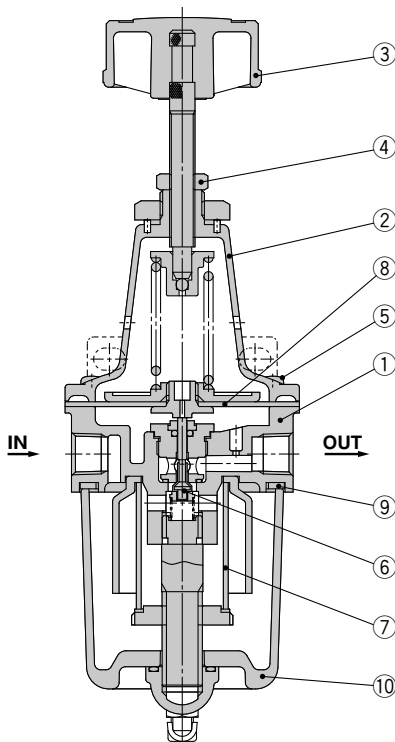

Component Parts

No.	Description	Material				Note
		Basic type			External main parts: Stainless steel	
		1301-002	1301-1202	1301-2502		
1	Decompression chamber	Zinc die-casted				Silver color
2	Bonnet	Zinc die-casted				Silver color
3	Handle	ABS/Brass		ABS/Stainless steel		—
4	Lock nut	Brass		Stainless steel		—
5	Round head Phillips screw	Brass		Stainless steel		—

Replacement Parts

No.	Description	Material	Part no.			
			Basic type			External main parts: Stainless steel
			1301-002	1301-1202	1301-2502	
6	Pilot valve	Stainless steel/NBR	1301207#1			1301207#1
7	Element	Bronze	1301111-5B			1301111-5B
8	Diaphragm assembly	Weather resistant NBR/ Brass/ADC	13014A			13014A
9	Bowl seal	NBR	130124			130124
10	Bowl assembly	ZDC/Brass	130191A			—
		ZDC/Stainless steel	—			130191A-S

Dimensions

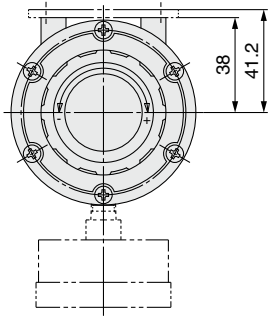

View A

Model	1301-002(BG) 1202(BG), 2502(BG)	1301-902(BG)
Dimensions		

	Horizontal mounting	Vertical mounting
Panel mounting hole		

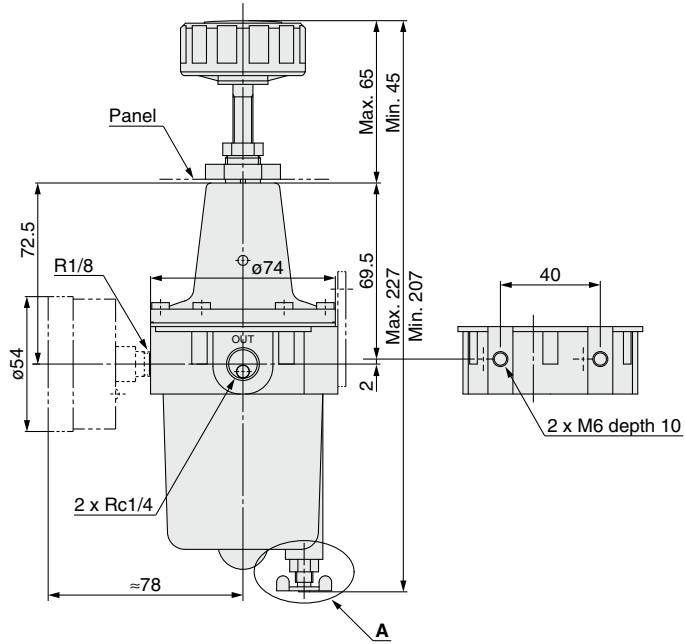
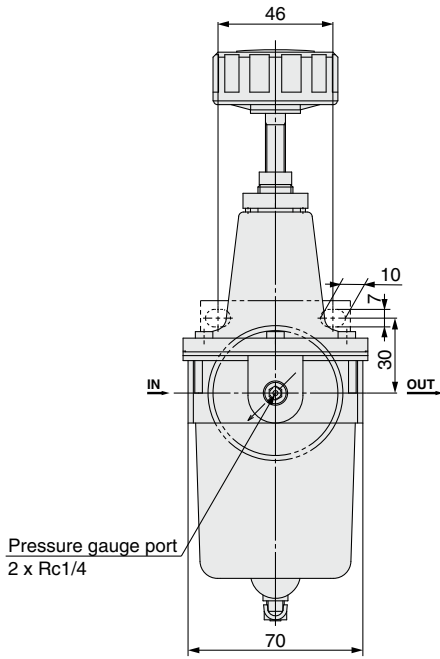

Positioners

Regulators

Relays/Valves

Electro-Pneumatic Transducers

Actuators

Detection Conversion Unit

Solenoid Valves

Air Preparation Equipment

Industrial Filters

Piping Materials

Filter Regulator AW30 to AW60 Made to Order



Please contact SMC for detailed dimensions, specifications, and lead times.

Special Temperature Environment

Special materials are used in the manufacturing of seals and resin parts to allow them to withstand various temperature conditions in cold or tropical (hot) climates.

Specifications

Made-to-Order part no.	-X430	-X440
Environment	Low temperature	High temperature
Ambient temperature (°C)	-30 to 60	-5 to 80
Fluid temperature (°C)	-5 to 60 (with no freezing)	
Material	Rubber parts	Special NBR / FKM
	Main parts	Metal (Aluminum die-cast, etc.)
Nominal filtration rating	5 μm	



Applicable Model

Model	AW30	AW40	AW40-06	AW60
Port size	1/4, 3/8	1/4, 3/8, 1/2	3/4	3/4, 1

AW30-03G-2-X440

- Option/Semi-standard: Select one each for **a** to **g**.
- Option/Semi-standard symbol: When more than one specification is required, indicate in alphanumeric order.
Example) AW30-03BG-2N-X430

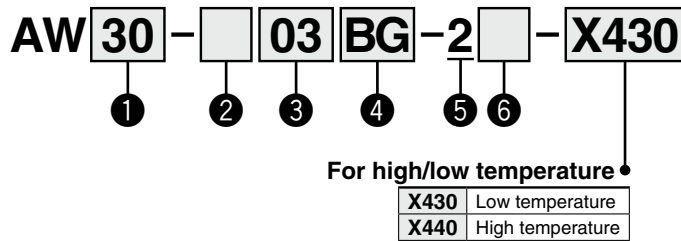

	Symbol	Description	① Body size				
			30	40	60		
② Thread type	Nil	Rc	●	●	●		
	N	NPT	●	●	●		
	F	G	●	●	●		
③ Port size	+						
	02	1/4	●	●	—		
	03	3/8	●	●	—		
	04	1/2	—	●	—		
	06	3/4	—	●	●		
④ Option	+	1	—	—	●		
	a	Mounting	●	●	●		
	B	With bracket	●	●	●		
	H	With set nut (for panel fitting)	●	●	—		
b	+						
	Pressure gauge	●	●	●			
G	Nil	Without pressure gauge	●	●	●		
	Note 3	Round type pressure gauge (without limit indicator)	●	●	●		
⑤ Bowl	Note 4	2	●	●	●		
⑥ Semi-standard	c	Set pressure	Nil	0.05 to 0.85 MPa setting	●	●	●
		Note 5	1	0.02 to 0.2 MPa setting	●	●	●
	d	Drain port	Nil	With drain cock	●	●	●
			Note 6	J	Drain guide 1/4	●	●
	e	Exhaust mechanism	Nil	Relieving type	●	●	●
			N	Non-relieving type	●	●	●
	f	Flow direction	Nil	Flow direction: Left to right	●	●	●
			R	Flow direction: Right to left	●	●	●
	g	Pressure unit	Nil	Name plate, caution plate for bowl, and pressure gauge in imperial units: MPa	●	●	●
			Note 7	Z	Name plate, caution plate for bowl, and pressure gauge in imperial units: psi, °F	○ Note 8)	○ Note 8)

Note 1) Option B, G, H are not assembled and supplied loose at the time of shipment.

Note 2) Assembly of a bracket and set nuts (AW30 to AW40)

Including 2 mounting screws for the AW60

Note 3) Mounting thread for pressure gauge: 1/8 for the AW30, 1/4 for the AW40 and AW60. Pressure gauge type: G43

Note 4) Only metal bowl 2 is available.

Note 5) The only difference from the standard specifications is the adjusting spring for the regulator. It does not restrict the setting of 0.2 MPa or more. When the pressure gauge is attached, a 0.2 MPa pressure gauge will be fitted.

Note 6) Without a valve function

Note 7) For thread type: NPT. This product is for overseas use only according to the new Measurement Law. (The SI unit type is provided for use in Japan.)

Note 8) ○: For thread type: NPT only

Dimensions

AW30-X430, -X440

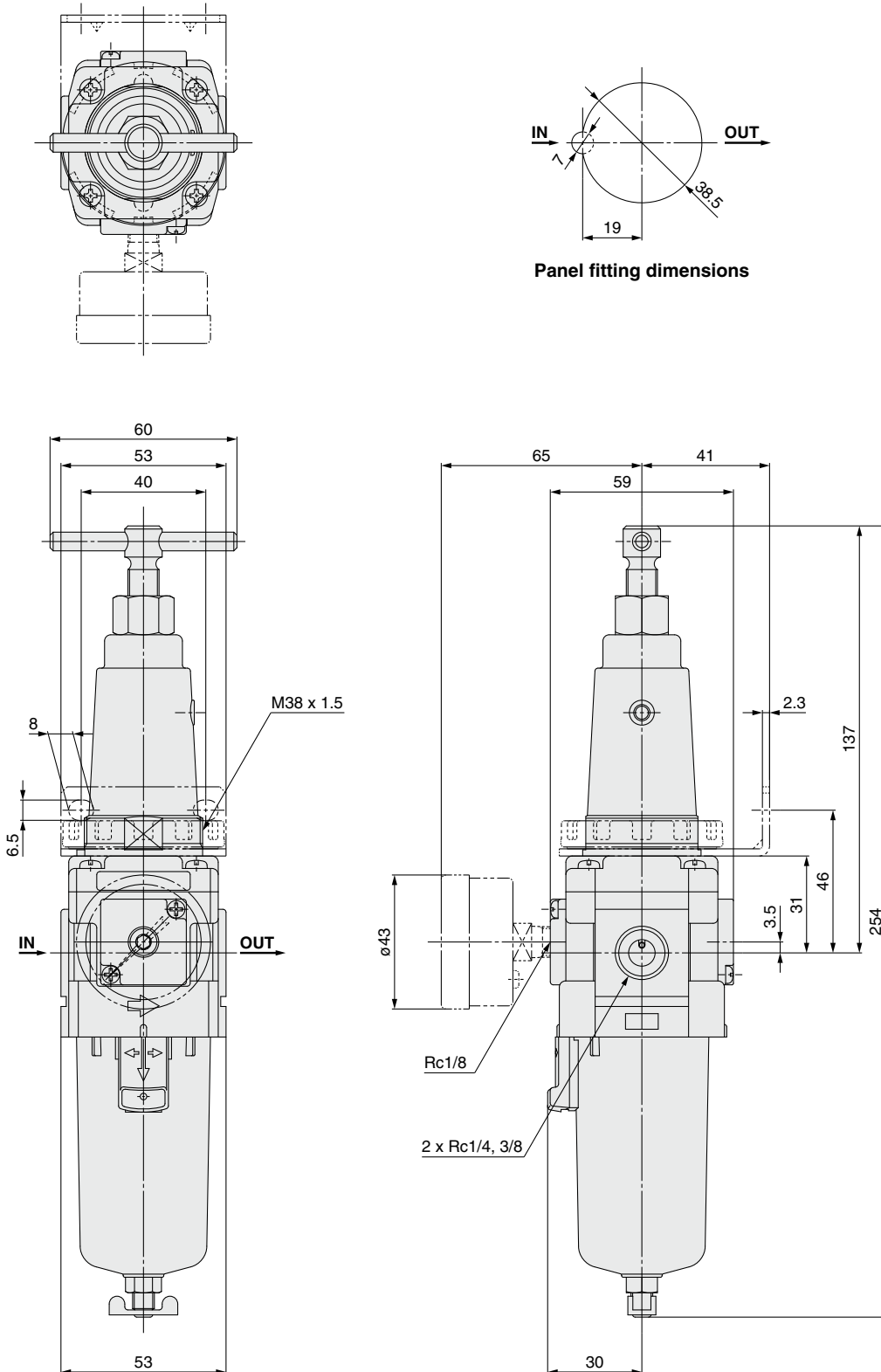

Positioners

Regulators

Relays/Valves

Electro-Pneumatic Transducers

Actuators

Detection Conversion Unit

Solenoid Valves

Air Preparation Equipment

Industrial Filters

Piping Materials

Filter Regulator

Stainless Steel 316 and Special Temperature Environment (-40°C) Specifications

AW30/40-X2622

- External parts material: Stainless steel 316
- Ambient and fluid temperature: -40 to 80°C
- NACE International Standards compliant

The JIS component standards of the external parts and the component measurement results of the certificate for materials are within the ANSI/NACE standards.



How to Order

AW **30** - **03** - **2** - X2622

① ② ③ ④ ⑤ ⑥

Stainless steel 316 specification ●

· Option/Semi-standard: Select one each for a to d.
 · Option/Semi-standard symbol: When more than one specification is required, indicate in alphanumeric order.
 Example) AW30-03C-2R-X2622A

		Symbol	Description	① Body size	
				30	40
②	Thread type	Nil	Rc	●	●
		N	NPT	●	●
		F	G	●	●
+					
③	Port size	02	1/4	●	●
		03	3/8	●	●
		04	1/2	—	●
		06	3/4	—	●
+					
④	Option i	a	Float type auto drain	●	●
		Nil	Without option	●	●
		C ^{Note 1)}	Float type auto drain (N.C.)	●	●
+					
⑤	Semi-standard	b	Bowl	●	●
		2 ^{Note 2)}	Metal bowl	●	●
		+			
⑥	Option ii	d	Pressure gauge ^{Note 3)}	●	●
			Bracket	●	●
		Nil	Without option	●	●
		A	Round type pressure gauge (without limit indicator)	●	●
		B	With bracket	●	●
		C	Round type pressure gauge (without limit indicator), With bracket	●	●

Note 1) When the float type auto drain is selected, the fluid temperature range is -5 to 60°C (with no freezing), and the maximum operating pressure is 1.0 MPa. Take measures if the fluid temperature is likely to be out of the specified range due to the ambient temperature.

Note 2) Only metal bowl is available.

Note 3) The pressure gauge is shipped together, but not assembled. AW30: G43-10-□01-X3 or AW40: G43-10-□02-X3 is included.

Specifications

Fluid	Air
Ambient and fluid temperature	-40 to 80°C (with no freezing)
Proof pressure	3.0 MPa
Maximum operating pressure	2.0 MPa
Set pressure range	0.05 to 0.85 MPa
Nominal filtration rating	5 μm
Drain capacity (cm ³)	AW30: 20, AW40: 80
Construction	Relieving type
Weight (kg)	AW30: 1.19, AW40: 3.40

Applicable Model

Model	AW30	AW40
Port size	1/4, 3/8	1/4, 3/8, 1/2, 3/4

Flow-rate Characteristics (Representative values)

Condition: Inlet pressure 0.7 MPa

AW30-02-2-X2622

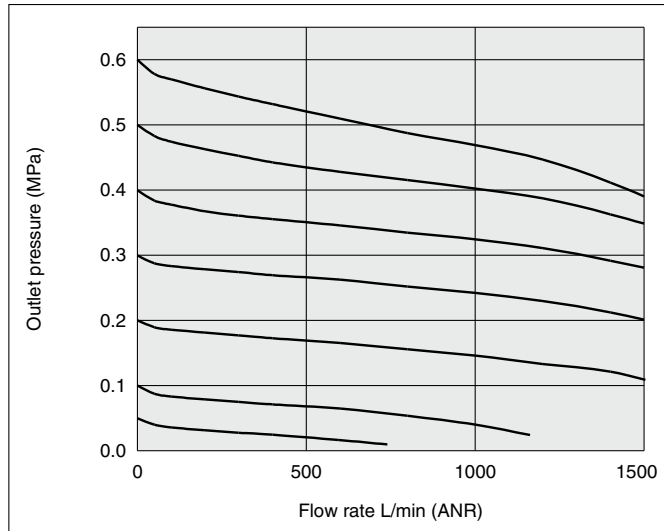

AW40-04-2-X2622

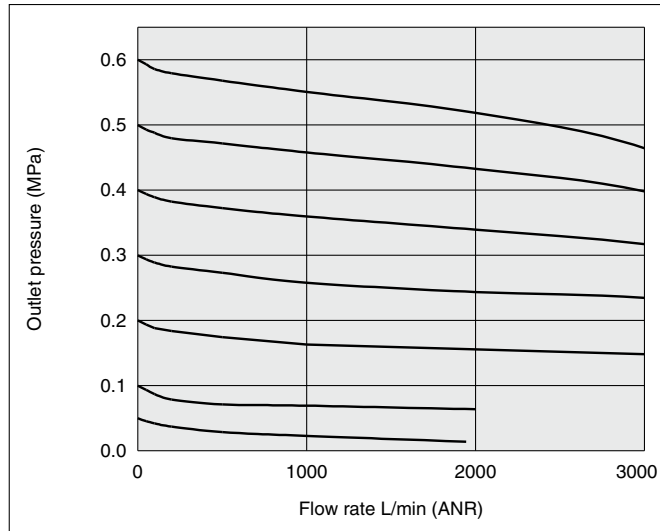

Pressure Characteristics (Representative values)

Conditions: Inlet pressure 0.7 MPa, Outlet pressure 0.2 MPa, Flow rate 20 L/min (ANR)

AW30-02-2-X2622

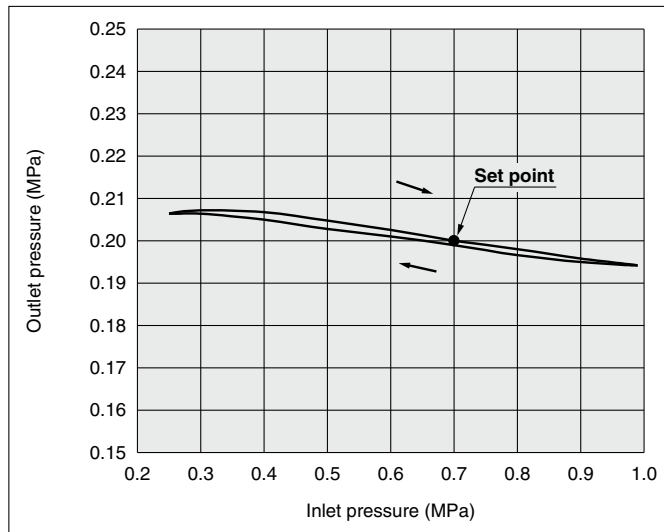

AW40-04-2-X2622

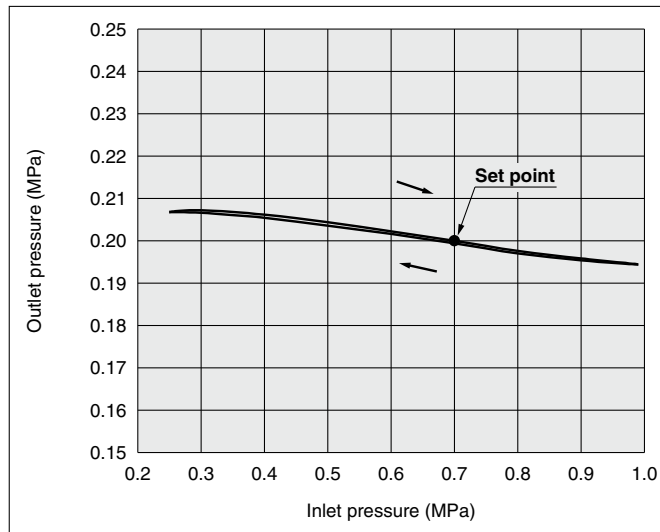

Positioners

Regulators

Relays/Valves

Electro-Pneumatic Transducers

Actuators

Detection Conversion Unit

Solenoid Valves

Air Preparation Equipment

Industrial Filters

Piping Materials

AW30/40-X2622

Construction

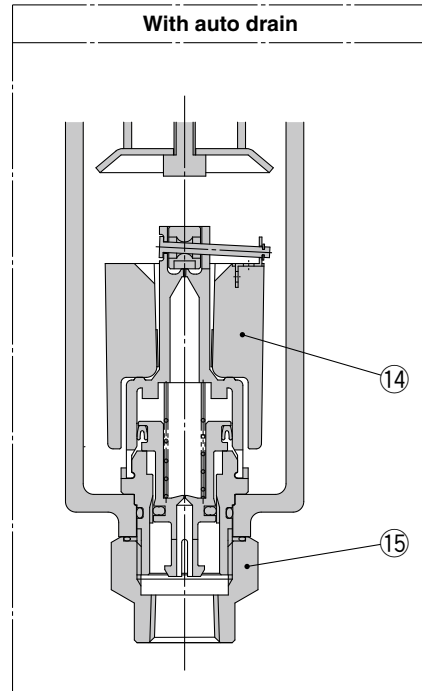
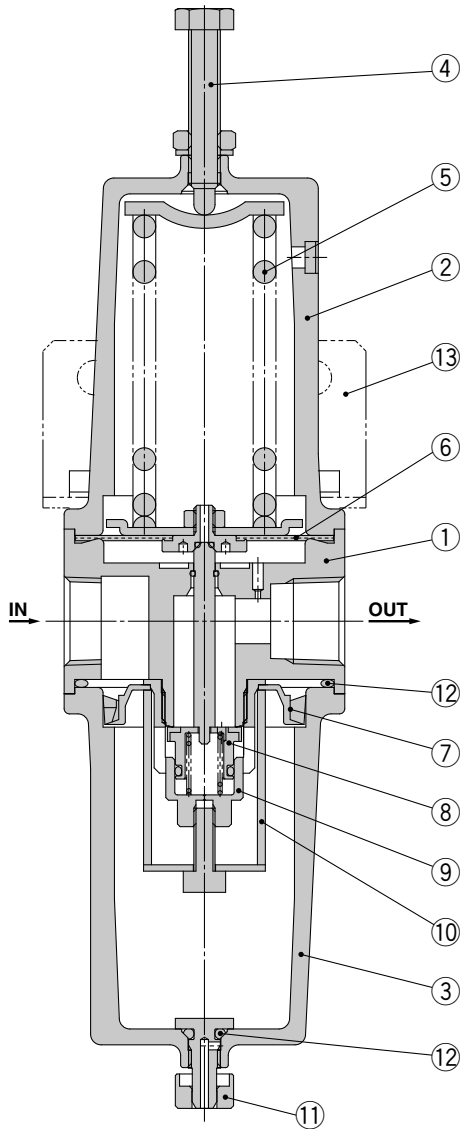

Component Parts

No.	Description	Material
1	Body	SCS14A (Equivalent to Stainless steel 316)
2	Bonnet	SCS14A (Equivalent to Stainless steel 316)
3	Bowl	SCS14A (Equivalent to Stainless steel 316)
4	Pressure adjustment screw	Stainless steel 316L
5	Adjusting spring	Stainless steel 304
6	Diaphragm	CR
7	Deflector	PBT
8	Valve	Stainless steel 316/Low-temperature NBR
9	Valve guide	Stainless steel 316
10	Element	Stainless steel 316L
11	Drain cock	Stainless steel 316
12	O-ring	Low-temperature NBR
13	Bracket	Stainless steel 316
14	Auto drain	POM/PBT/Foamed phenol/NBR etc.
15	Drain guide	Stainless steel 316

Dimensions

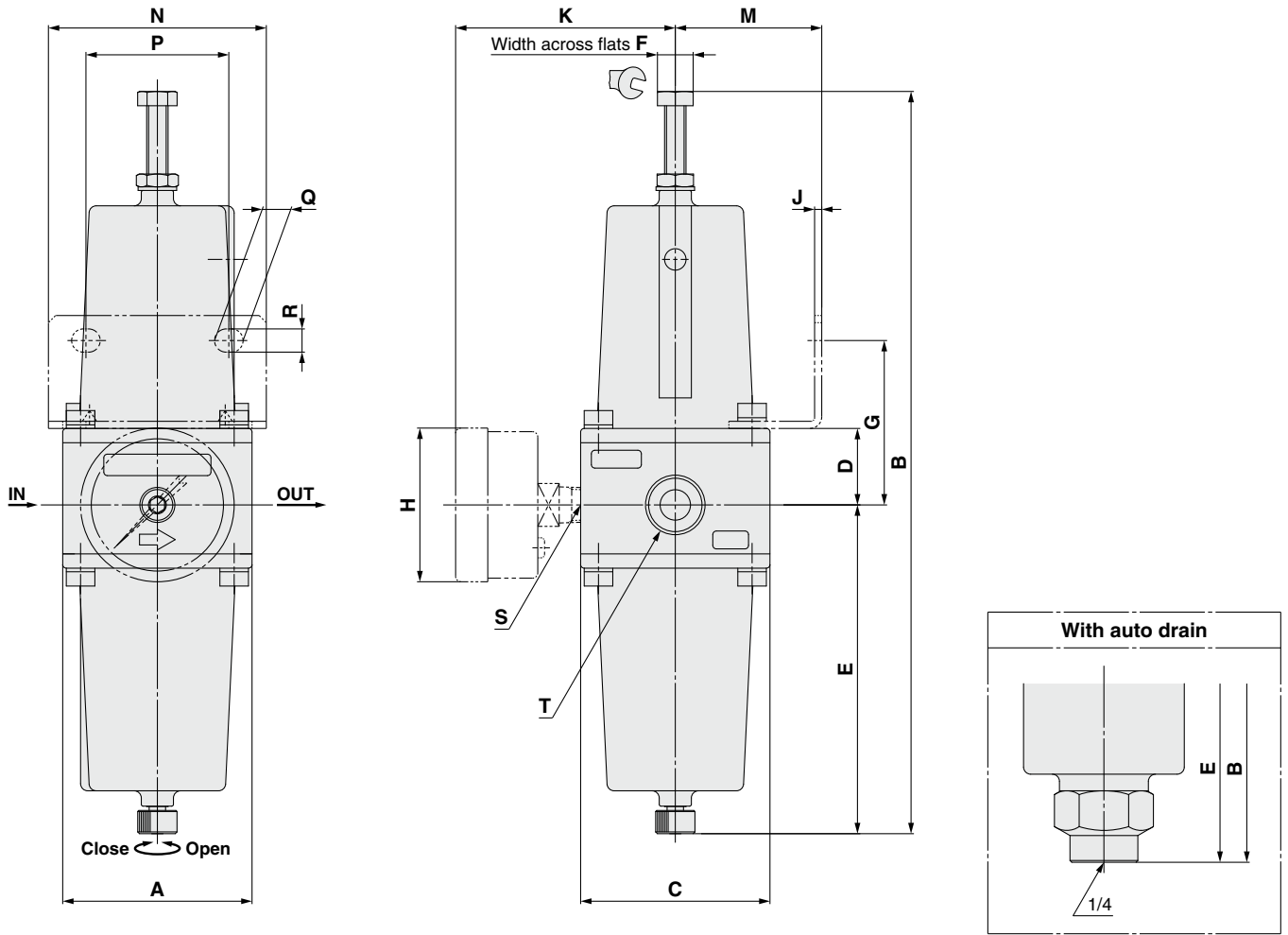

Model	T	A	B	C	D	E	F	G	H	J	K	M	N	P	Q	R	S	With auto drain	
																		B	E
AW30-X2622	1/4, 3/8	53	208	53	21.4	92	10	46	ø43	2	61.5	41	61	40	8	6.5	1/8	255	139.5
AW40-X2622	1/4, 3/8, 1/2, 3/4	75	334	72	29.8	146	13	56	ø43	2.5	73	50	80	54	10.5	8.5	1/4	366	178

- Positioners
- Regulators
- Relays/Valves
- Electro-Pneumatic Transducers
- Actuators
- Detection Conversion Unit
- Solenoid Valves
- Air Preparation Equipment
- Industrial Filters
- Piping Materials



Precision Regulator *IR*

Pressure Control
Equipment

- Setting sensitivity: Within 0.2% F.S.
- Repeatability: Within $\pm 0.5\%$ F.S.



Series	Port size	Set pressure (MPa)
IR1000	1/8	0.005 to 0.2
IR2000	1/4	0.01 to 0.4 0.01 to 0.8
IR3000	1/4, 3/8, 1/2	0.01 to 0.2 0.01 to 0.4 0.01 to 0.8

Pneumatic Instrumentation Equipment

Relays/Valves



Relay

Booster Relay/IL100 Page 53

Valves

Lock-Up Valve/IL201/211/220 Page 56

Positioners

Regulators

Relays/Valves

Electro-Pneumatic Transducers

Actuators

Detection Conversion Unit

Solenoid Valves

Air Preparation Equipment

Industrial Filters

Piping Materials

Booster Relay

Series IL100

- Used when the piping distance between instrumentation and operational area is long, or when operational area has large capacity.
- Can help accelerate actuation speed considerably.

How to Order

IL 100 - [] 02 [] - []

Booster relay

Thread type

Nil	Rc
N	NPT*
F	G*

* Semi-standard

Port size

02	1/4
03	3/8

Suffix

Nil	Standard
T	High temperature (-5 to 100°C)
L	Low temperature (-30 to 60°C)
S	Copper-free
ST	Copper-free/ High temperature (-5 to 100°C)
SL	Copper-free/ Low temperature (-30 to 60°C)

Accessories

Nil	None
B	With bracket



Standard Specifications

Supply pressure	Max. 1.0 MPa
Input pressure	Max. 0.7 MPa
Output pressure	Max. 0.7 MPa
Pressure ratio	1 : 1
Air consumption	3 L/min (ANR) or less (OUT = 0.5 MPa)
Linearity	Within $\pm 1\%$
Hysteresis	Within 1%
Ambient and fluid temperature	-5 to 60°C
Port size	1/4, 3/8
Weight	0.56 kg

Flow-rate Characteristics

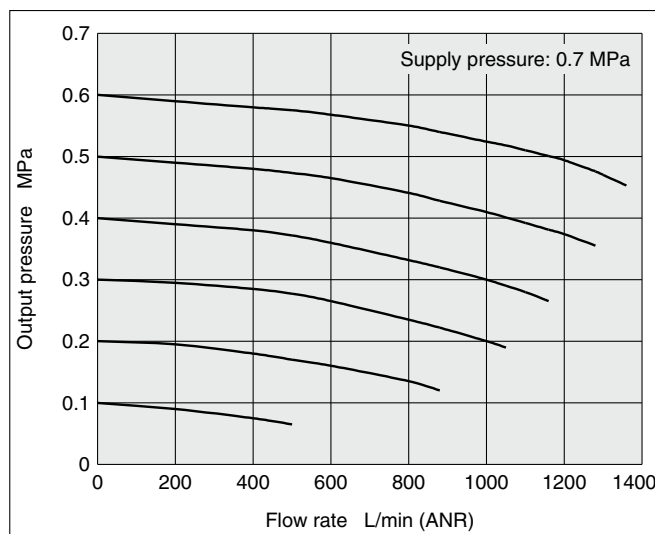

Principle of Operation

IL100

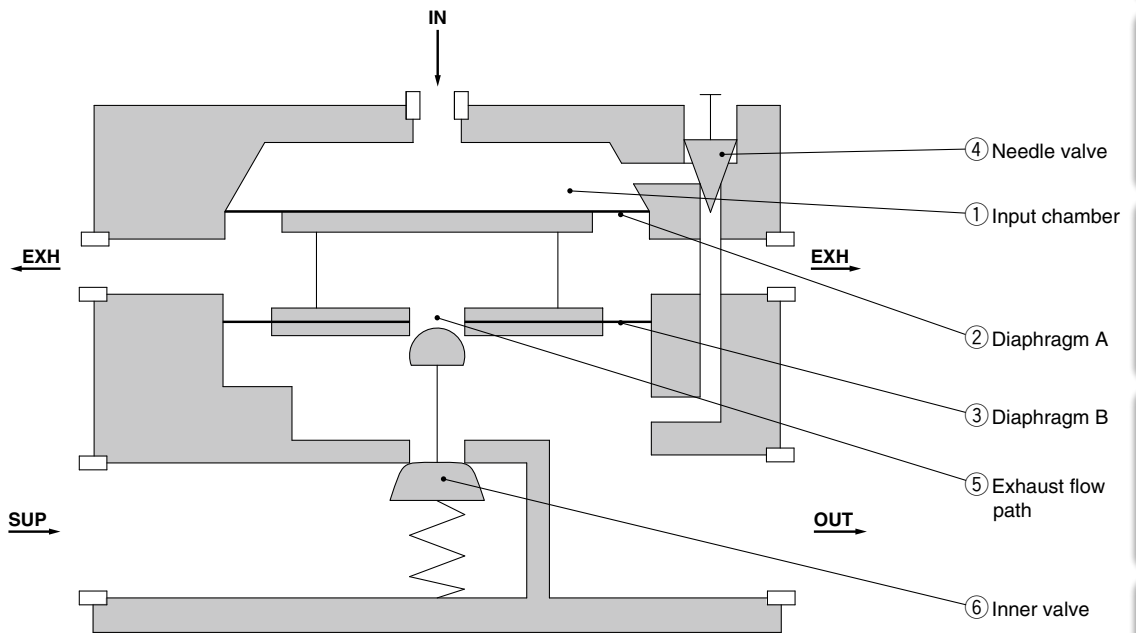

Signal pressure enters the input chamber ① and diaphragm A ② and exerts a downward force on diaphragm B ③. When the force of the input chamber ① exceeds the force of diaphragm B ③, inner valve ⑥ is inserted allowing air flow out the secondary supply port. On signal pressure exhaust the supply valve closes and exhaust flow path ⑤ is opened to allow vent of the secondary air supply to atmosphere. Input and output ports are connected by a needle valve ④. Adjustment ensures that exact equalization occurs between the signal and output supply. The above function allows a low volume signal to provide high volume output with pressure ratio remaining (1:1) for signal to output.

Construction

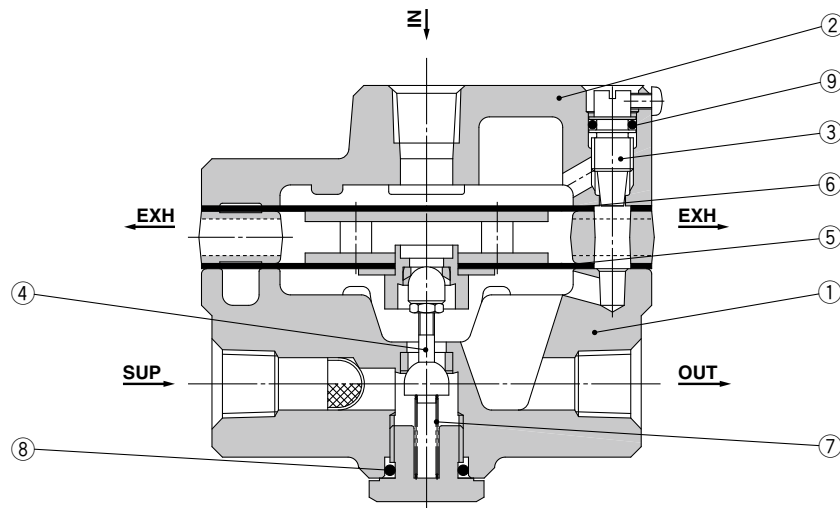

Component Parts

No.	Description	Material	Note
1	Valve	Aluminum alloy	Silver baking finish
2	Cover	Aluminum alloy	Silver baking finish
3	Throttle valve	Stainless steel	
4	Inner valve	Stainless steel	
5	Diaphragm assembly	Aluminum alloy/NBR/Resin	Chromated
6	Diaphragm	NBR	
7	Valve spring	Stainless steel	
8	O-ring	NBR	
9	O-ring	NBR	

Replacement Parts

Model	Order no.	Contents
IL100	KT-IL100	Set of left nos. ⑤, ⑥, ⑦, ⑧, ⑨

Series IL100

Dimensions

IL100

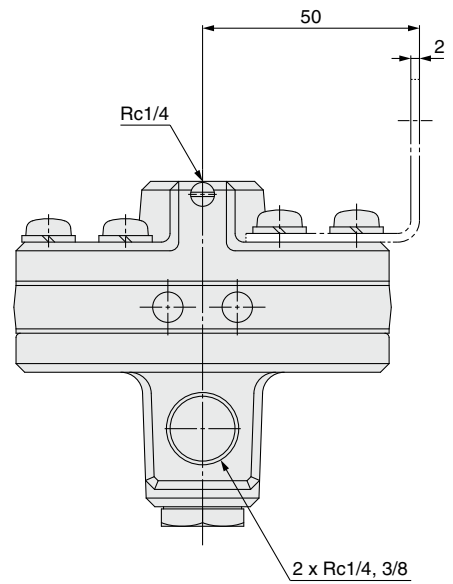
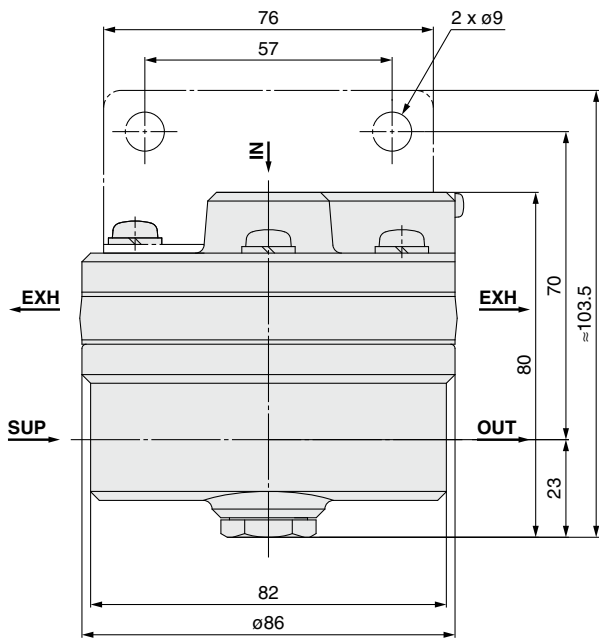

Lock-Up Valve

Series IL201/211/220

- The lock-up valve is used if any air source or air supply piping line failure occurs in the air operated process control line.

Single acting, Double acting: Retains pressure at the operating area as emergency operation until the air source is recovered to its normal state.

3 Port: Changes the supply port if a trouble occurs.

How to Order

IL 201 - [] 02 [] - []

Action

201	Single acting
211	Double acting
220	3 Port

Thread type

Nil	Rc
N	NPT*
F	G*

* Semi-standard

Port size

02	1/4
----	-----

Accessories

Nil	None
B	With bracket

Suffix

Nil	Standard
T	High temperature (-5 to 100°C)
L	Low temperature (-30 to 60°C)
S	External parts copper-free
ST	External parts copper-free/ High temperature (-5 to 100°C)
SL	External parts copper-free/ Low temperature (-30 to 60°C)

Standard Specifications

Model	IL201	IL211	IL220
Action	Single acting	Double acting	3 Port
Signal pressure	Max. 1.0 MPa <small>Note 1)</small>		
Set pressure range	0.14 to 0.7 MPa <small>Note 1)</small>		
Shut-off pneumatic circuit pressure	Max. 0.7 MPa		
Ambient and fluid temperature	-5 to 60°C		
Port size	Rc1/4		
Differential <small>Note 2)</small>	0.01 MPa		
Weight	0.45 kg	0.64 kg	0.7 kg

Note 1) Provide a differential pressure of 0.1 MPa or more between the signal pressure and set pressure. If the differential pressure is small, the internal part is worn out due to the structure of this product and the bleed amount from the exhaust port increases, which may affect the characteristics.

Note 2) Pressure difference between lock activated and lock released

Principle of Operation

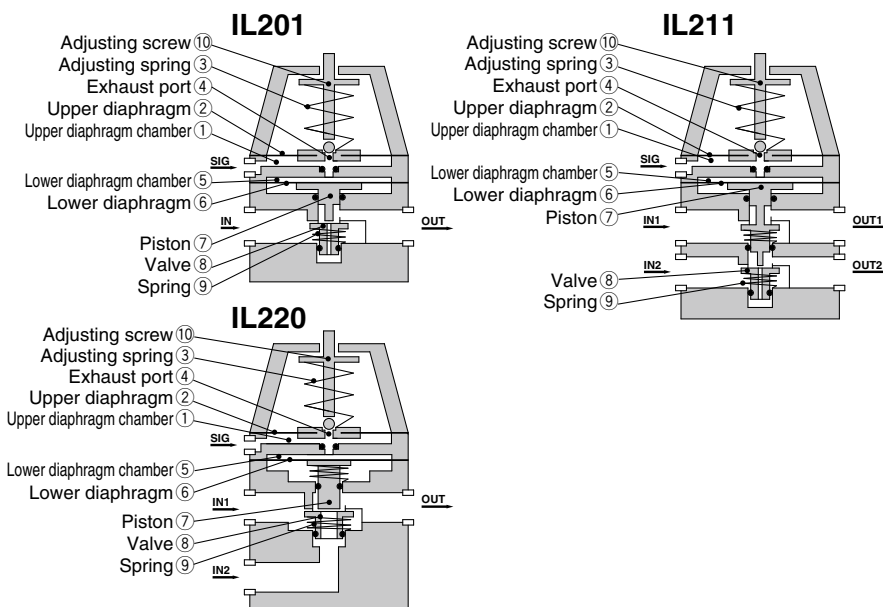

The signal air pressure enters the upper diaphragm chamber ① to generate a force. When this force is larger than the force generated by compressing the adjusting spring ③, the upper diaphragm ② is pushed up, the exhaust port ④ is closed, and the signal air pressure enters the lower diaphragm chamber ⑤ and acts the lower diaphragm ⑥. This pushes down the piston ⑦ to open the valve. IL201 and IL211 enter the status, in which the flow path between IN and OUT is opened. IL220 enters the status, in which the flow path between IN1 and OUT is opened. If the signal air pressure drops to a level below the set pressure for some reason, the upper diaphragm ② is pushed down, the pressure inside the lower diaphragm chamber ⑤ is exhausted from the exhaust port ④, and the valve ⑧ is closed by the force of the spring ⑨. At this time, IN and OUT are shut down in IL201 and IL211. In IL220, IN1 and OUT are shut down, and the flow path between IN2 and OUT is opened. The set pressure is adjusted with the adjusting screw ⑩.

Series IL201/211/220

Construction

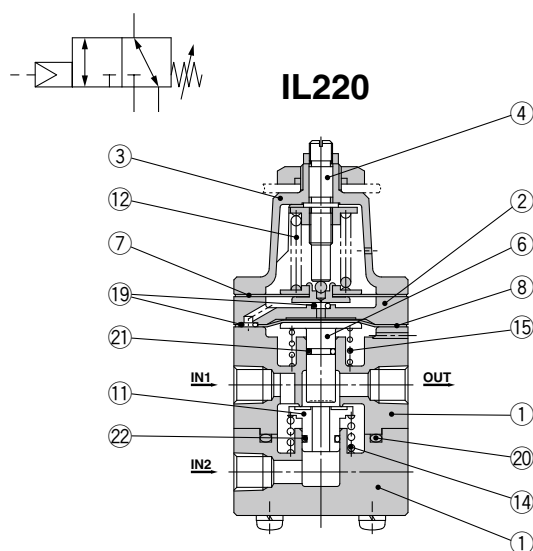
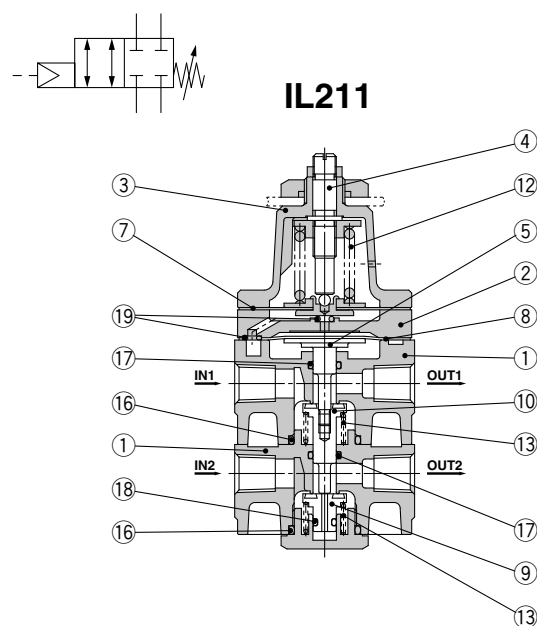
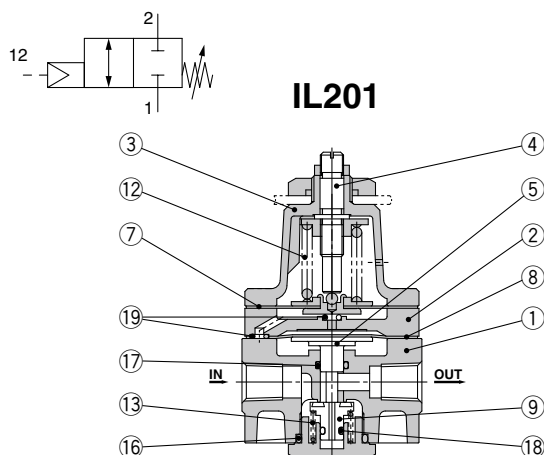

Component Parts

No.	Description	Material	Note
1	Body	Aluminum alloy	Silver baking finish
2	Pilot body	Aluminum alloy	Silver baking finish
3	Bonnet	Aluminum alloy	Silver baking finish
4	Adjusting screw	Stainless steel	
5	Piston	Brass	
6	Piston rod	Brass	
7	Diaphragm assembly	Aluminum alloy/Brass/NBR	Chromated
8	Diaphragm	NBR	
9	Piston valve	Brass/NBR	
10	Piston valve	Brass/NBR	
11	Valve	Brass/NBR	
12	Adjusting spring	Steel wire	Zinc chromated
13	Valve spring	Stainless steel	
14	Valve spring	Stainless steel	
15	Piston spring	Stainless steel	
16	O-ring	NBR	
17	O-ring	NBR	
18	O-ring	NBR	
19	O-ring	NBR	
20	O-ring	NBR	
21	O-ring	NBR	
22	O-ring	NBR	

Replacement Parts

Model	Order no.	Contents
IL201	KT-IL201	Set of left nos. ⑦, ⑧, ⑨, ⑫, ⑬, ⑯, ⑰, ⑱
IL211	KT-IL211	Set of left nos. ⑦, ⑧, ⑨, ⑩, ⑫, ⑬, ⑯, ⑰, ⑱
IL220	KT-IL220	Set of left nos. ⑦, ⑧, ⑪, ⑫, ⑭, ⑮, ⑰, ⑲, ⑳, ㉑, ㉒

Dimensions

IL201

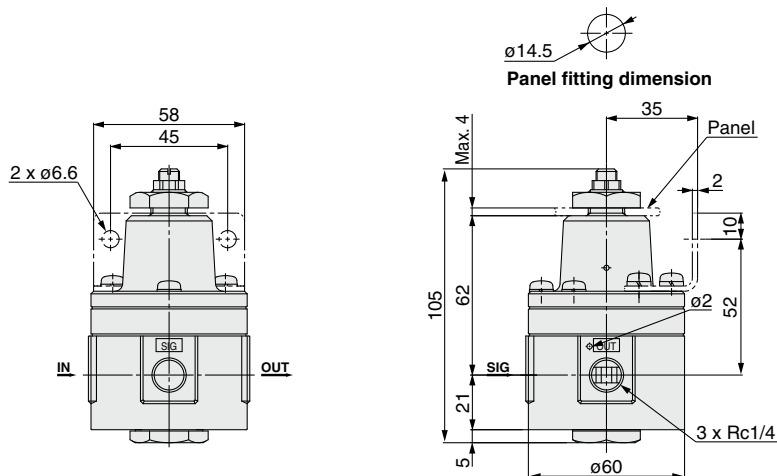

IL211

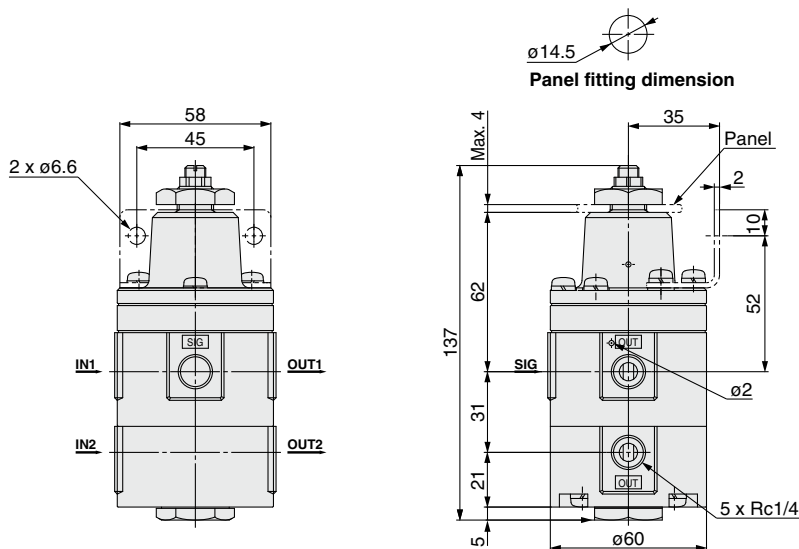

IL220

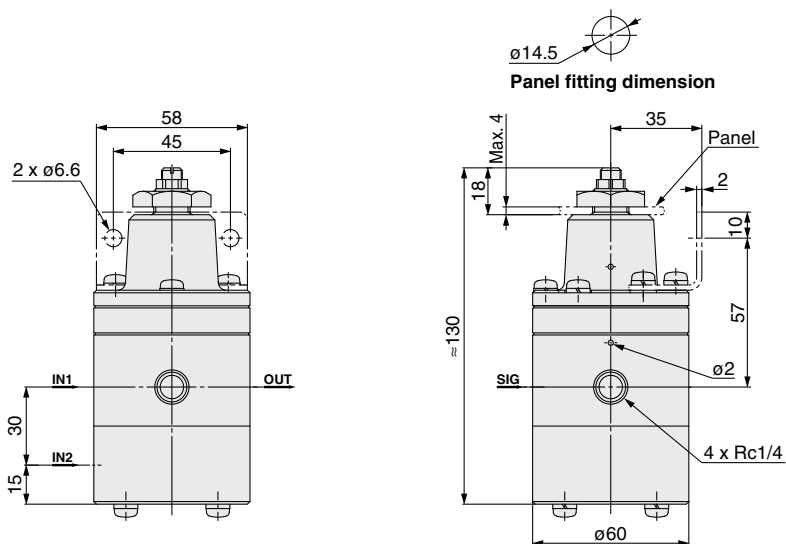

Pneumatic Instrumentation Equipment

Electro-Pneumatic Transducers



Electro-Pneumatic Transducer/IT600 Page 60

Electro-Pneumatic Transducer

Series IT600

- **The air pressure in proportion to the current signal can be output.**
Can be used as input pressure signal in combination with the pneumatic-pneumatic positioner.
- **Wide output pressure range/0.02 to 0.6 MPa**
The maximum pressure can be set freely through the span adjustment.
- **Fast response**
The pilot valve capacity is large and the large flow can be obtained. Therefore, the response is excellent when operating the actuator directly or controlling the inner pressure of the tank with a large capacity.
- **Independent electric unit/Explosion-proof (flameproof) construction**
The span adjustment, zero-point adjustment, and inspection maintenance can be performed with the body cover removed even in a hazardous place where the explosion or fire may occur.
- **Easy span adjustment**
As the span adjustment mechanism uses a vector mechanism, the span adjustment can be performed smoothly.

Output pressure setting range

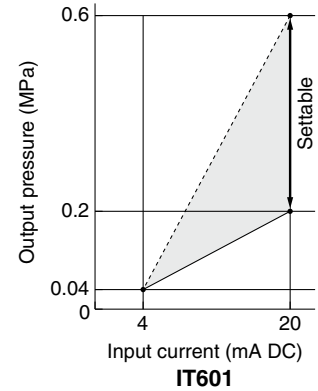
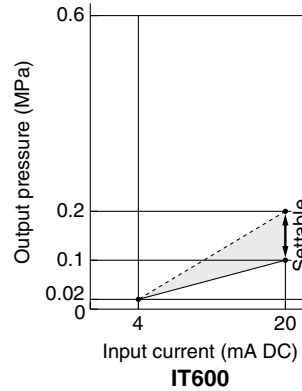

How to Order

IT60 0 - 0 0 0 - 0

Output pressure

0	0.02 to 0.2 MPa
1	0.04 to 0.6 MPa

Input current

0	4 to 20 mA DC
---	---------------

Options

Nil	None
B	Bracket (2 ^B pipe installation)
J	Hexagon wrench (for tightening terminal cover)

Pressure gauge*

0	None
1	0.2 MPa
2	0.3 MPa
3	1 MPa
4	0.4 MPa
6	0.6 MPa

External wiring connection

0	Flameproof threaded-joint metal conduit and normal joint not requiring explosion-proof design
1	Flameproof packing type cable gland

Seal type

0	None
1	Applicable cable O.D. 7 to 7.9 mm
2	Applicable cable O.D. 8 to 8.9 mm
3	Applicable cable O.D. 9 to 9.9 mm
4	Applicable cable O.D. 10 to 10.9 mm
5	Applicable cable O.D. 11 to 11.5 mm
6	A complete set of 5 types of flameproof packing

Specifications

Item	Model	
	IT600	IT601
Input current	4 to 20 mA DC	
Input impedance	235 Ω (4 to 20 mA, 20°C)	
Supply air pressure	0.14 to 0.24 MPa	0.24 to 0.7 MPa
Output pressure	0.02 to 0.1 MPa (Max. 0.2 MPa)	0.04 to 0.2 MPa (Max. 0.6 MPa)
Linearity	Within ±1.0% F.S.	
Hysteresis	Within 0.75% F.S.	
Repeatability	Within ±0.5% F.S.	
Air consumption	7 L/min (ANR) (SUP = 0.14 MPa)	22 L/min (ANR) (SUP = 0.7 MPa)
Ambient and fluid temperature	-10 to 60°C	
Air connection port	Rc1/4 female thread	
Electrical connection	Rc1/2 female thread	
Explosion-proof construction	Explosion-proof (flameproof) construction d2G4 (Certificate no. T28926)	
Material	Aluminum die-cast body	
Weight	3 kg	

Replacement Parts

Part no.	Description	Note
P255010-1	Pilot valve unit	IT600
P255010-19	Pilot valve unit	IT601

Series IT600

Principle of Operation

When the input current increases, armature ① in the torque motor will be subjected to a clockwise torque, pushing flapper lever ② to the left. As a result, the clearance of nozzle flapper ③ will increase and the nozzle back pressure will decrease. This moves exhaust valve ⑩ of pilot valve ⑤ to the left, causing the output air pressure of OUT1 to increase.

The output pressure thus increased is passed through the path inside the pilot valve to pressure sensing bellows ⑥, where it is converted to the force. This force acts on vector mechanism ⑦ via lever ⑪. Because the force will balance the force

generated by means of the input current at lever fulcrum ⑫, the output air pressure proportional to the input current will be obtained.

Gain suppressing spring ⑧ functions to immediately feedback the movement of the exhaust valve to the flapper lever, thereby contributing to loop stability.

Zero point and span adjustments are performed by varying the tension force of zero adjusting spring ⑨ and the angle of the vector mechanism, respectively.

Block diagram illustrating operating principle

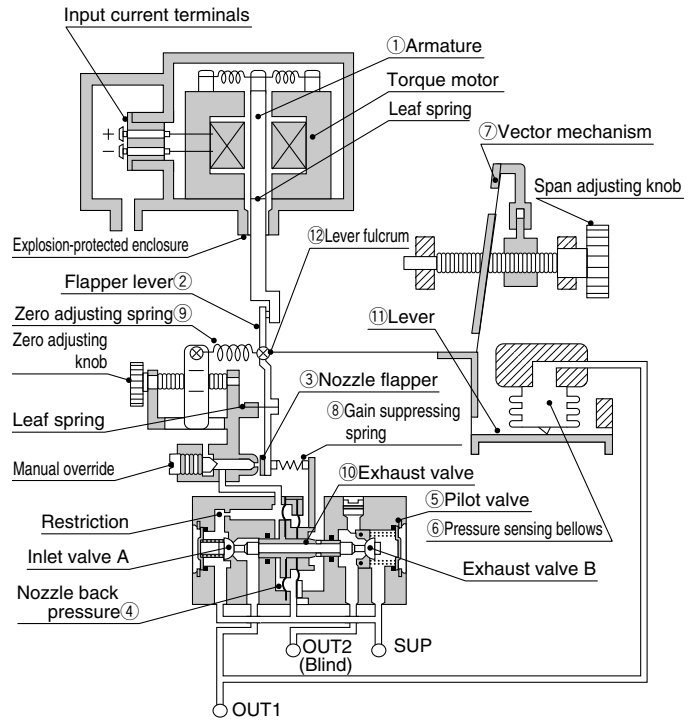
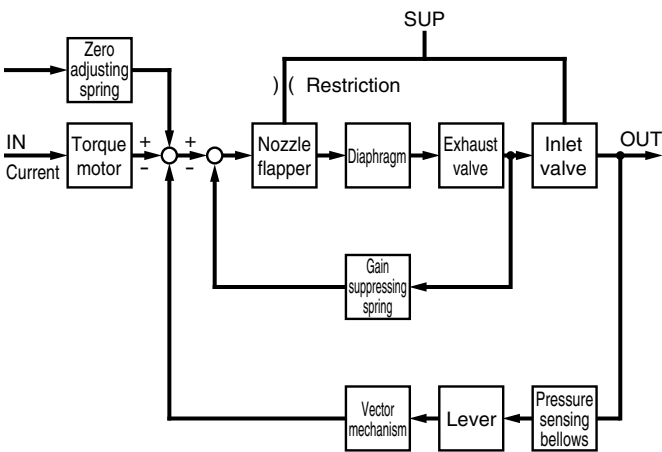

Dimensions

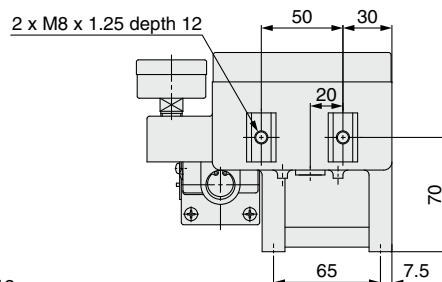
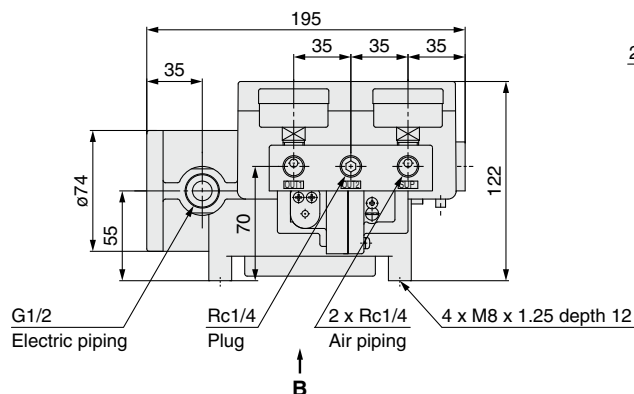
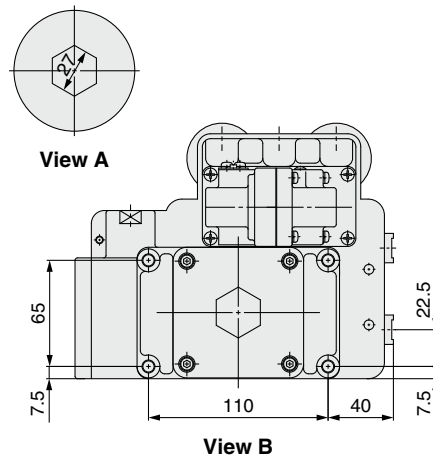
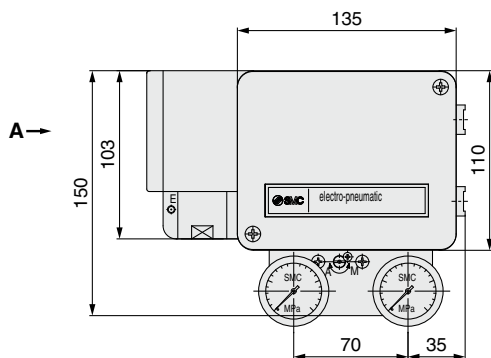

P Cylinder (Cylinder with Positioner)

Series CPA2/CPS1

CPA2 \varnothing 50, \varnothing 63, \varnothing 80, \varnothing 100

CPS1 \varnothing 125, \varnothing 140, \varnothing 160, \varnothing 180, \varnothing 200, \varnothing 250, \varnothing 300

- The cylinder positioning in proportion to the input signal (air pressure) is possible.
- Correction operation function: Returns to the initial setting position even when the position deviates due to load variations.

How to Order

Bore size \varnothing 50 to 100

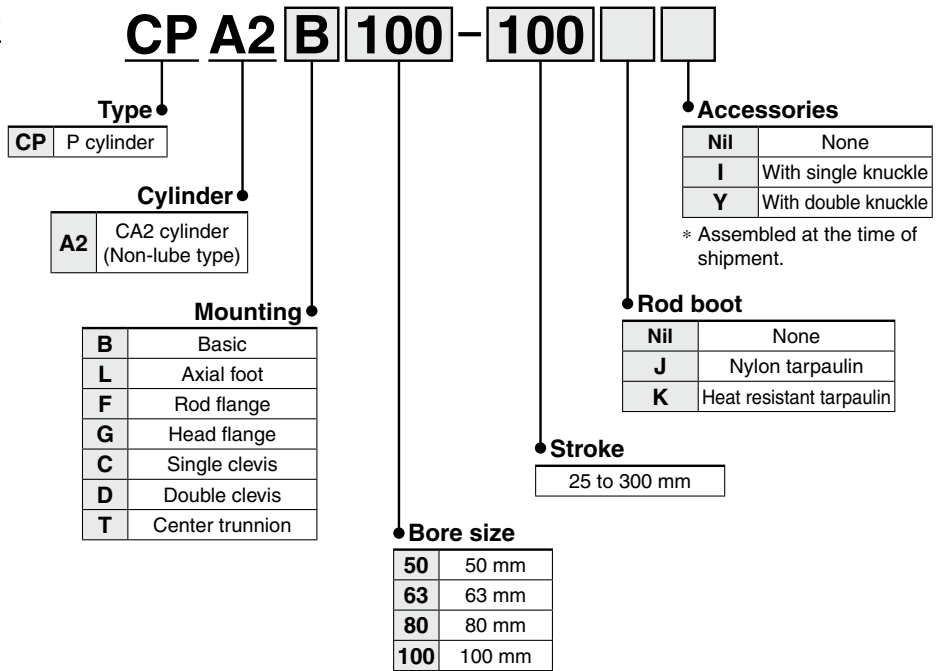
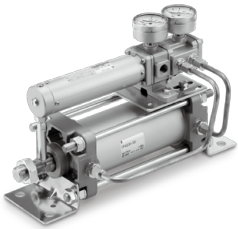

Bore size \varnothing 125 to 300

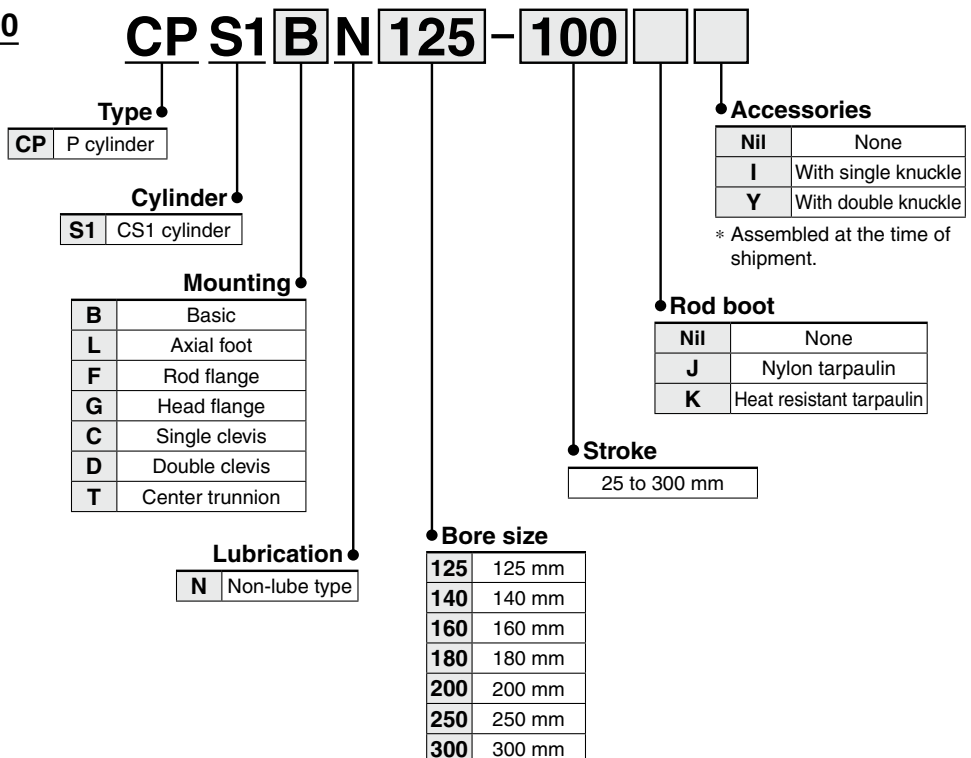

Specifications

Item	Model	
	CPA2	CPS1
Input pressure	0.02 to 0.1 MPa	
Supply pressure	0.3 to 0.7 MPa	
Linearity	Within $\pm 2\%$ F.S.	
Hysteresis	Within 1% F.S.	
Repeatability	Within $\pm 1\%$ F.S.	
Sensitivity	Within 0.5% F.S.	
Air consumption	18 L/min (ANR) or less (SUP = 0.5 MPa) ^{Note 1)}	
Ambient and fluid temperature	-5°C to 60°C (No freezing)	0°C to 60°C (No freezing)
Coefficient of temperature	0.1% F.S./°C	
Stroke adjustment margin	Within 10% F.S.	
Applicable cylinder stroke	25 mm (Min.) to 300 mm (Max.)	
Air connection port	Rc1/4 female thread ^{Note 2)}	

Note 1) (ANR) indicates JIS B0120 standard air.

Note 2) Please contact SMC for connection ports other than the standard.

Construction/Principle of Operation

When input pressure enters input chamber ①, the input diaphragm ③ is deflected left. Clearance of the nozzle ⑥ is reduced causing higher back pressure at diaphragm A ⑦.

This diaphragm A ⑦ has larger area than diaphragm B ⑧ resulting in movement of the spool to the left. Supply pressure then flows to OUT1 ① and the air inside the cylinder is exhausted from OUT2, resulting in cylinder rod ⑤ movement to the right. The movement is linked via connecting rod ④ and feedback spring ② to the input diaphragm ③ balancing the higher pressure. When this occurs nozzle ⑥ clearance increases allowing centralizing of the spool ⑨ to take place. This holds the piston rod in the new position. Input signal increase results in proportional movement of the piston rod.

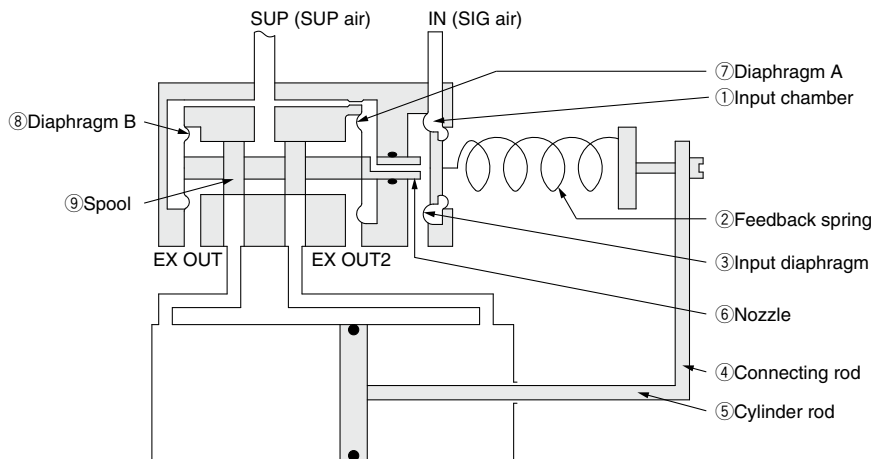

Series CPA2

Dimensions

Basic: CPA2B

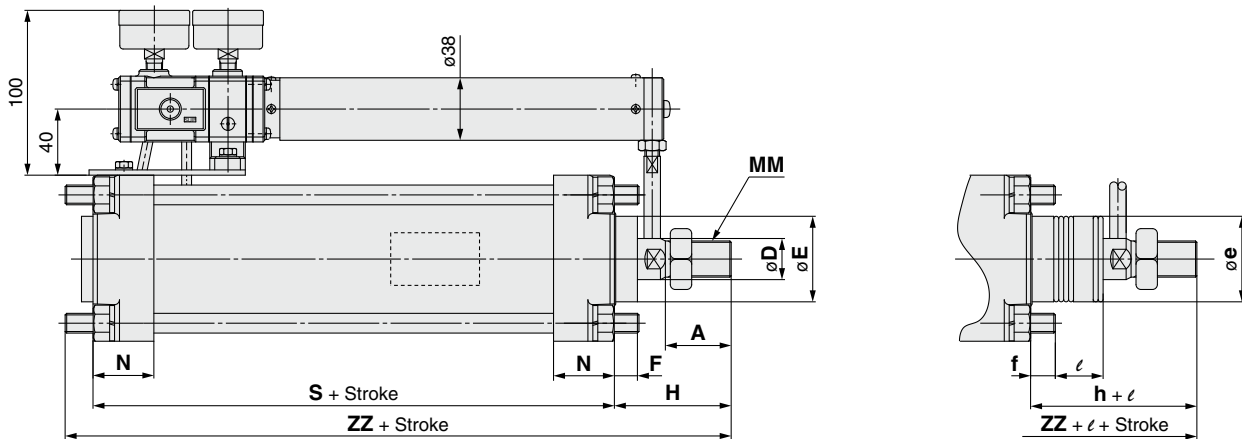
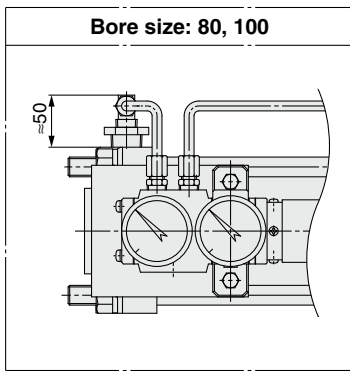
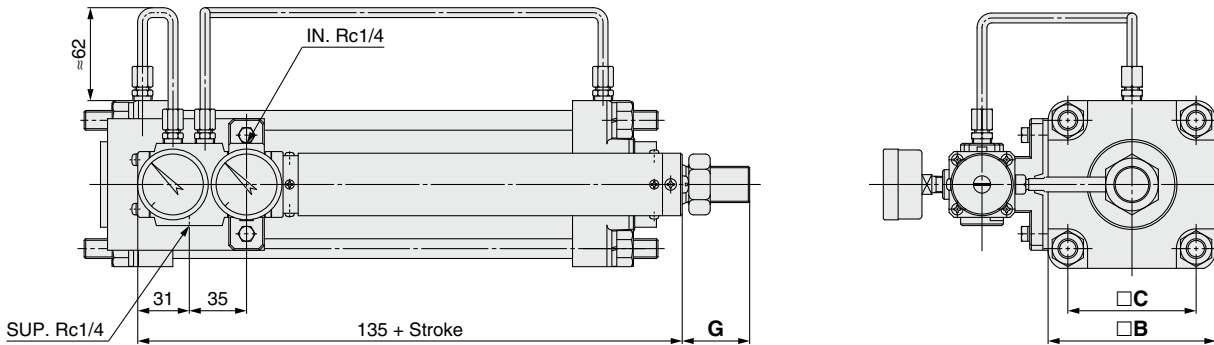

With rod boot

Dimensions

Bore size	A	□B	□C	øD	øE	F	G	N	S	MM	Without rod boot		With rod boot				
											H	ZZ	øe	f	h	l	ZZ
50	35	70	52	20	40	10	31	30	90	M18 x 1.5	58	159	52	11.2	66	1/4 stroke	167
63	35	85	64	20	40	10	31	31	98	M18 x 1.5	58	170	52	11.2	66		178
80	40	102	78	25	52	14	41	37	116	M22 x 1.5	71	204	65	12.5	80		213
100	40	116	92	30	52	14	41	40	126	M26 x 1.5	72	215	65	14	81		224

Note 1) Use only dehumidified and dust extracted clean compressed air as the air supply.

Note 2) Install a cylinder so that the cylinder rod might not be twisted.

Note 3) Do not apply force to the protective cover of the feedback spring.

Note 4) The zero point is subject to the mounting position. Adjust zero point after installation on the site.

Note 5) Do not use a lubricator.

Note 6) Cylinder dimensions are the same as those of the CA2 series. For details, refer to the **WEB catalog** or the Best Pneumatics No. 2.

Note 7) When using the cylinder outdoors, take measures to avoid wind and rain.

Dimensions

Axial foot: CPA2L

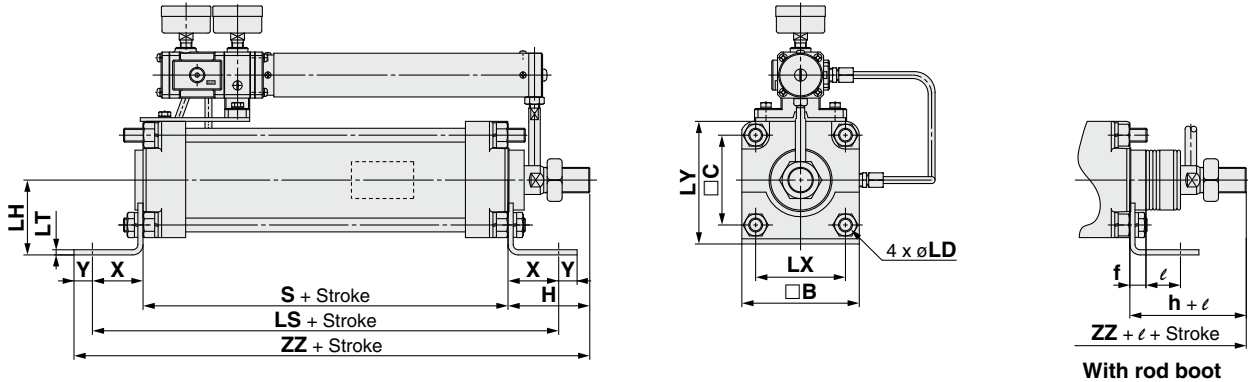

Dimensions

Bore size	□B	□C	S	X	Y	øLD	LH	LS	LT	LX	LY	Without rod boot		With rod boot			
												H	ZZ	f	h	ℓ	ZZ
50	70	52	90	27	13	9	45	144	3.2	50	80	58	188	11.2	66	1/4 stroke	196
63	85	64	98	34	16	11.5	50	166	3.2	59	93	58	206	11.2	66		214
80	102	78	116	44	16	13.5	65	204	4.5	76	116	71	247	12.5	80		256
100	116	92	126	43	17	13.5	75	212	6	92	133	72	258	14	81		267

- Note 1) Use only dehumidified and dust extracted clean compressed air as the air supply.
- Note 2) Install a cylinder so that the cylinder rod might not be twisted.
- Note 3) Do not apply force to the protective cover of the feedback spring.
- Note 4) The zero point is subject to the mounting position. Adjust zero point after installation on the site.

- Note 5) Do not use a lubricator.
- Note 6) Cylinder dimensions are the same as those of the CA2 series. For details, refer to **the WEB catalog** or the Best Pneumatics No. 2.
- Note 7) When using the cylinder outdoors, take measures to avoid wind and rain.

Rod flange: CPA2F

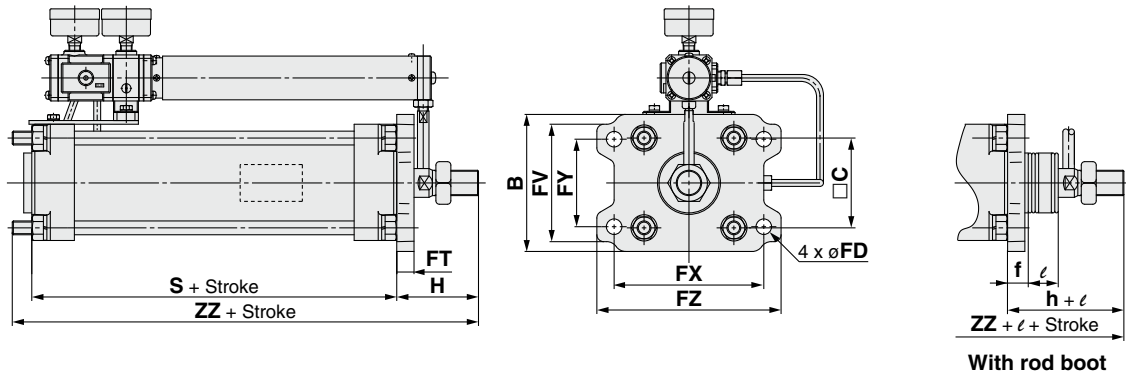

Dimensions

Bore size	B	□C	S	FV	øFD	FT	FX	FY	FZ	Without rod boot		With rod boot			
										H	ZZ	f	h	ℓ	ZZ
50	81	52	90	70	9	12	90	50	110	58	159	15	66	1/4 stroke	167
63	101	64	98	86	11.5	15	105	59	130	58	170	17.5	66		178
80	119	78	116	102	13.5	18	130	76	160	71	204	21.5	80		213
100	133	92	126	116	13.5	18	150	92	180	72	215	21.5	81		224

- Note 1) Use only dehumidified and dust extracted clean compressed air as the air supply.
- Note 2) Install a cylinder so that the cylinder rod might not be twisted.
- Note 3) Do not apply force to the protective cover of the feedback spring.
- Note 4) The zero point is subject to the mounting position. Adjust zero point after installation on the site.

- Note 5) Do not use a lubricator.
- Note 6) Cylinder dimensions are the same as those of the CA2 series. For details, refer to **the WEB catalog** or the Best Pneumatics No. 2.
- Note 7) When using the cylinder outdoors, take measures to avoid wind and rain.

Series CPA2

Dimensions

Head flange: CPA2G

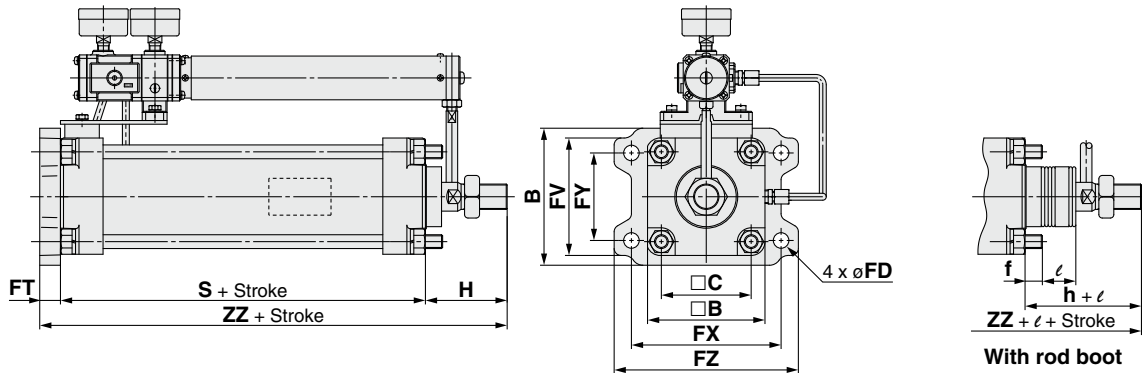

Dimensions

Bore size	B	□B	□C	S	FV	øFD	FT	FX	FY	FZ	Without rod boot		With rod boot			
											H	ZZ	f	h	ℓ	ZZ
50	81	70	52	90	70	9	12	90	50	110	58	160	11.2	66	1/4 stroke	168
63	101	85	64	98	86	11.5	15	105	59	130	58	171	11.2	66		179
80	119	102	78	116	102	13.5	18	130	76	160	71	205	12.5	80		214
100	133	116	92	126	116	13.5	18	150	92	180	72	216	14	81		225

Note 1) Use only dehumidified and dust extracted clean compressed air as the air supply.
 Note 2) Install a cylinder so that the cylinder rod might not be twisted.
 Note 3) Do not apply force to the protective cover of the feedback spring.
 Note 4) The zero point is subject to the mounting position. Adjust zero point after installation on the site.

Note 5) Do not use a lubricator.
 Note 6) Cylinder dimensions are the same as those of the CA2 series. For details, refer to the WEB catalog or the Best Pneumatics No. 2.
 Note 7) When using the cylinder outdoors, take measures to avoid wind and rain.

Single clevis: CPA2C

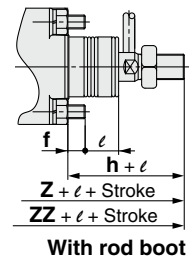
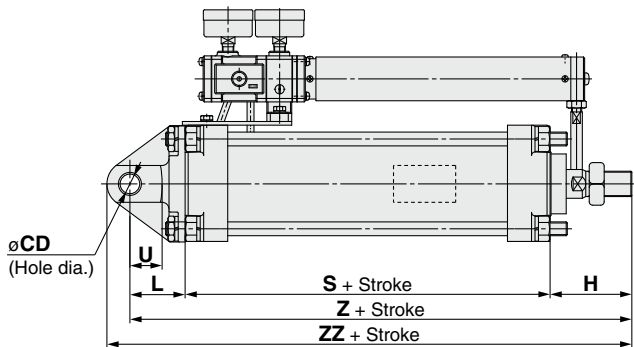
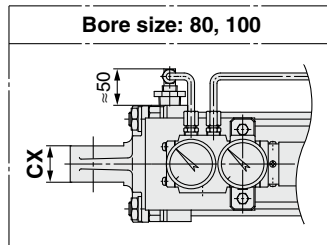
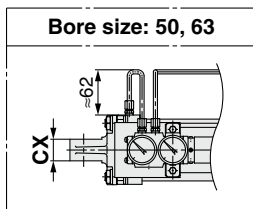

Dimensions

Bore size	L	S	U	øCD _{H10}	CX	Without rod boot			With rod boot				
						H	Z	ZZ	f	h	ℓ	Z	ZZ
50	35	90	19	12 ^{+0.070} ₀	18.0 ^{-0.1} _{-0.3}	58	183	195	11.2	66	1/4 stroke	191	203
63	40	98	23	16 ^{+0.070} ₀	25.0 ^{-0.1} _{-0.3}	58	196	212	11.2	66		204	220
80	48	116	28	20 ^{+0.084} ₀	31.5 ^{-0.1} _{-0.3}	71	235	255	12.5	80		244	264
100	58	126	36	25 ^{+0.084} ₀	35.5 ^{-0.1} _{-0.3}	72	256	281	14	81		265	290

Note 1) Use only dehumidified and dust extracted clean compressed air as the air supply.
 Note 2) Install a cylinder so that the cylinder rod might not be twisted.
 Note 3) Do not apply force to the protective cover of the feedback spring.
 Note 4) The zero point is subject to the mounting position. Adjust zero point after installation on the site.

Note 5) Do not use a lubricator.
 Note 6) Cylinder dimensions are the same as those of the CA2 series. For details, refer to the WEB catalog or the Best Pneumatics No. 2.
 Note 7) When using the cylinder outdoors, take measures to avoid wind and rain.

Dimensions

Double clevis: CPA2D

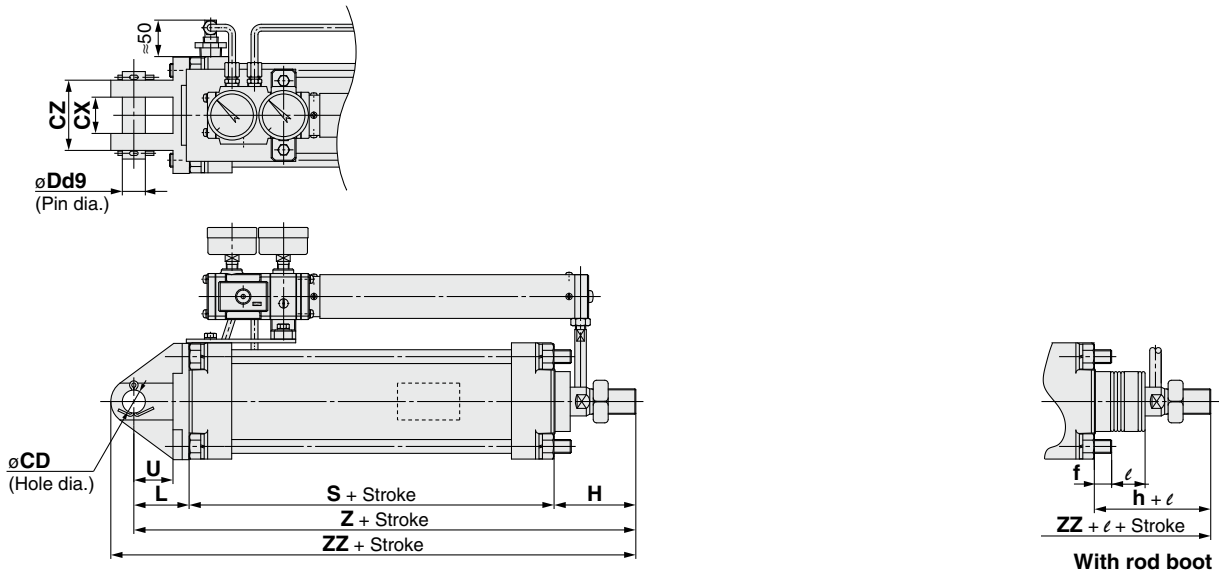

Dimensions

Bore size	L	S	U	øCD _{H10}	CX	CZ	øDd9	Without rod boot			With rod boot				
								H	Z	ZZ	f	h	ℓ	Z	ZZ
50	35	90	19	12 ^{+0.070} ₀	18.0 ^{+0.3} _{+0.1}	38	12 ^{-0.050} _{-0.093}	58	183	195	11.2	66	1/4 stroke	191	203
63	40	98	23	16 ^{+0.070} ₀	25.0 ^{+0.3} _{+0.1}	49	16 ^{-0.050} _{-0.093}	58	196	212	11.2	66		204	220
80	48	116	28	20 ^{+0.084} ₀	31.5 ^{+0.3} _{+0.1}	61	20 ^{-0.065} _{-0.117}	71	235	255	12.5	80		244	264
100	58	126	36	25 ^{+0.084} ₀	35.5 ^{+0.3} _{+0.1}	64	25 ^{-0.065} _{-0.117}	72	256	281	14	81		265	290

- Note 1) Use only dehumidified and dust extracted clean compressed air as the air supply.
- Note 2) Install a cylinder so that the cylinder rod might not be twisted.
- Note 3) Do not apply force to the protective cover of the feedback spring.
- Note 4) The zero point is subject to the mounting position. Adjust zero point after installation on the site.

- Note 5) Do not use a lubricator.
- Note 6) Cylinder dimensions are the same as those of the CA2 series. For details, refer to **the WEB catalog** or the Best Pneumatics No. 2.
- Note 7) When using the cylinder outdoors, take measures to avoid wind and rain.

Center trunnion: CPA2T

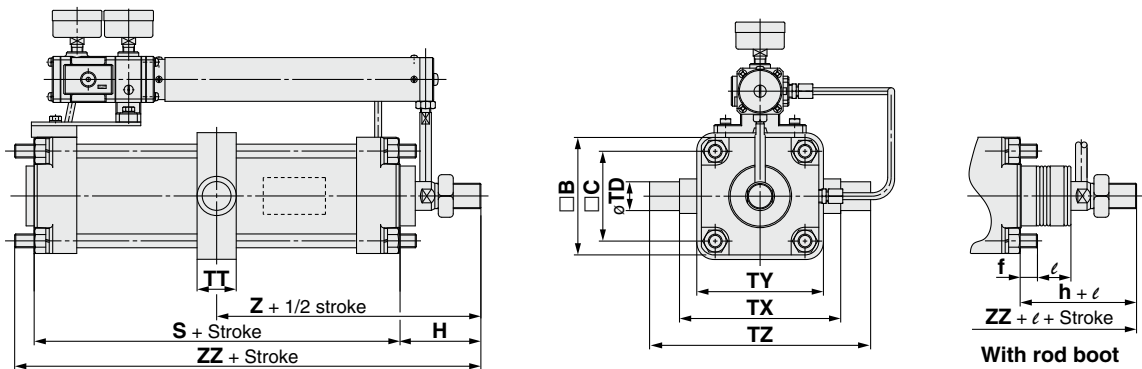

Dimensions

Bore size	□B	□C	S	øTD _{e8}	TT	TX	TY	TZ	Without rod boot			With rod boot				
									H	Z	ZZ	f	h	ℓ	Z	ZZ
50	70	52	90	15 ^{-0.032} _{-0.059}	22	95	74	127	58	103	154	11.2	66	1/4 stroke	111	162
63	85	64	98	18 ^{-0.032} _{-0.059}	28	110	90	148	58	107	162	11.2	66		115	170
80	102	78	116	25 ^{-0.040} _{-0.073}	34	140	110	192	71	129	194	12.5	80		138	203
100	116	92	126	25 ^{-0.040} _{-0.073}	40	162	130	214	72	135	206	14	81		144	215

- Note 1) Use only dehumidified and dust extracted clean compressed air as the air supply.
- Note 2) Install a cylinder so that the cylinder rod might not be twisted.
- Note 3) Do not apply force to the protective cover of the feedback spring.
- Note 4) The zero point is subject to the mounting position. Adjust zero point after installation on the site.

- Note 5) Do not use a lubricator.
- Note 6) Cylinder dimensions are the same as those of the CA2 series. For details, refer to **the WEB catalog** or the Best Pneumatics No. 2.
- Note 7) When using the cylinder outdoors, take measures to avoid wind and rain.

Positioners
Regulators
Relays/Valves
Electro-Pneumatic Transducers
Actuators
Detection Conversion Unit
Solenoid Valves
Air Preparation Equipment
Industrial Filters
Piping Materials

Series CPS1

Dimensions

Basic: CPS1B

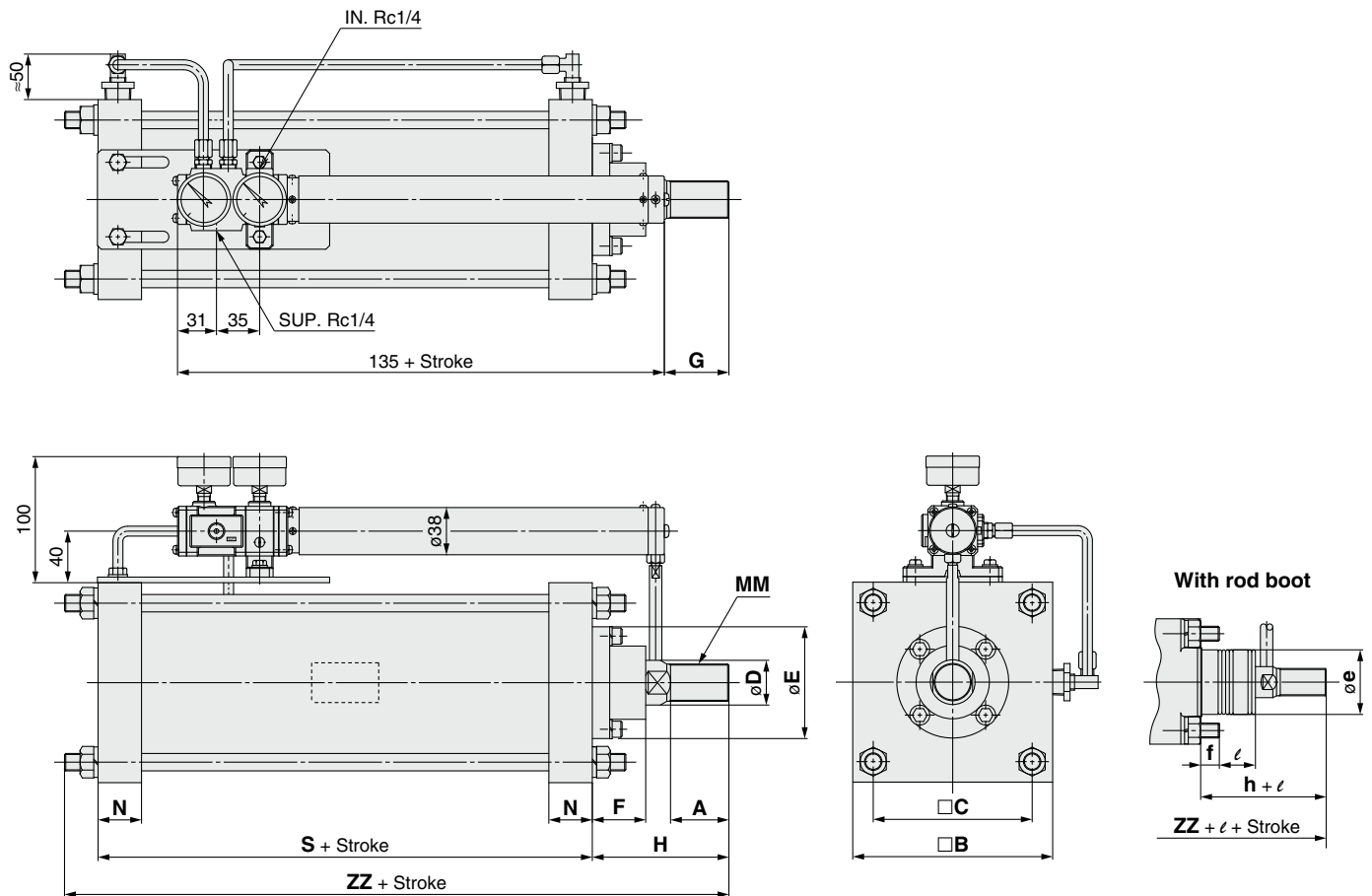

Dimensions

(mm)

Bore size	A	□B	□C	ϕD	ϕE	F	G	MM	N	S	Without rod boot		With rod boot				
											H	ZZ	ϕe	f	h	l	ZZ
125	50	145	115	36	90	43	52	M30 x 1.5	35	98	110	235	75	40	133	0.2 stroke	258
140	50	161	128	36	90	43	52	M30 x 1.5	35	98	110	235	75	40	133		258
160	56	182	144	40	90	43	59	M36 x 1.5	39	106	120	256.5	75	40	141		277.5
180	63	204	162	45	115	48	66	M40 x 1.5	39	111	135	281	85	45	153		299
200	63	226	182	50	115	48	66	M45 x 1.5	39	111	135	281	90	45	153		299
250	71	277	225	60	140	60	77	M56 x 2.0	49	141	160	342.5	105	55	176	0.17 stroke	358.5
300	80	330	270	70	140	60	88	M64 x 2.0	49	146	175	372.5	115	55	190		387.5

Note 1) If the air is not for pneumatic instrumentation, install a mist separator on the supply pressure side.

Note 2) Install a cylinder so that the cylinder rod might not be twisted.

Note 3) Do not apply force to the protective cover of the feedback spring.

Note 4) The zero point is subject to the mounting position. Adjust zero point after installation on the site.

Note 5) Do not use a lubricator.

Note 6) Cylinder dimensions are the same as those of the CS1 series. For details, refer to the **WEB catalog** or the Best Pneumatics No. 2.

Note 7) When using the cylinder outdoors, take measures to avoid wind and rain.

Dimensions

Axial foot: CPS1L

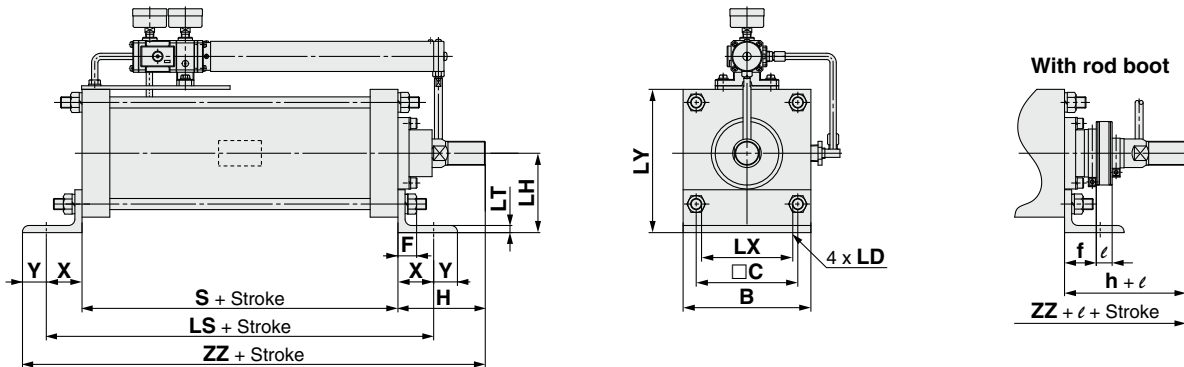

Dimensions

Bore size	B	□C	F	S	X	Y	LD	LH	LS	LT	LX	LY	Without rod boot		With rod boot			
													H	ZZ	f	h	ℓ	ZZ
125	145	115	43	98	45	20	19	85	188	8	100	157.5	110	273	40	133	0.2 stroke	296
140	161	128	43	98	45	30	19	100	188	9	112	180.5	110	283	40	133		306
160	182	144	43	106	50	25	19	106	206	9	118	197.0	120	301	40	141		322
180	204	162	48	111	60	30	24	125	231	10	132	227.0	135	336	45	153		354
200	226	182	48	111	60	30	24	132	231	10	150	245.0	135	336	45	153	354	
250	277	225	60	141	80	40	29	160	301	12	180	298.5	160	421	55	176	0.17 stroke	437
300	330	270	60	146	90	40	33	200	326	15	212	365.0	175	451	55	190		466

- Note 1) If the air is not for pneumatic instrumentation, install a mist separator on the supply pressure side.
 Note 2) Install a cylinder so that the cylinder rod might not be twisted.
 Note 3) Do not apply force to the protective cover of the feedback spring.
 Note 4) The zero point is subject to the mounting position. Adjust zero point after installation on the site.

- Note 5) Do not use a lubricator.
 Note 6) Cylinder dimensions are the same as those of the CS1 series. For details, refer to the **WEB catalog** or the Best Pneumatics No. 2.

Rod flange: CPS1F

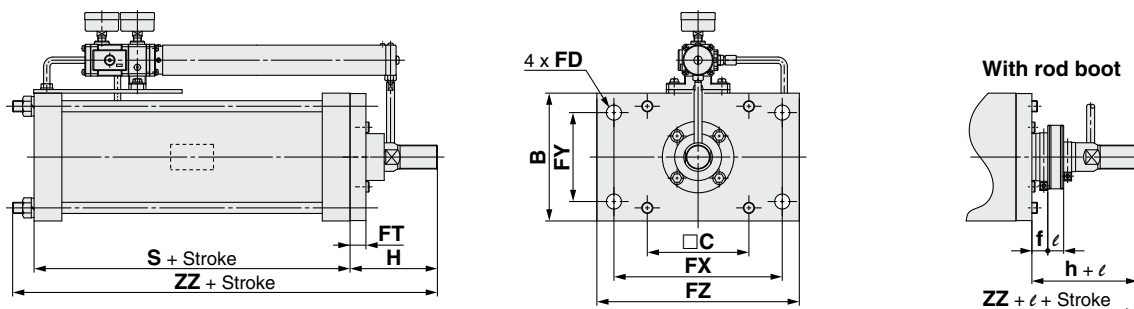

Dimensions

Bore size	B	□C	S	FD	FT	FX	FY	FZ	Without rod boot		With rod boot			
									H	ZZ	f	h	ℓ	ZZ
125	145	115	98	19	14	190	100	230	110	238	40	133	0.2 stroke	261
140	160	128	98	19	20	212	112	255	110	232	40	133		255
160	180	144	106	19	20	236	118	275	120	252	40	141		273
180	200	162	111	24	25	265	132	320	135	277	45	153		295
200	225	182	111	24	25	280	150	335	135	277	45	153	295	
250	275	225	141	29	30	355	180	420	160	336	55	176	0.17 stroke	352
300	330	270	146	33	30	400	212	475	175	369	55	190		384

- Note 1) If the air is not for pneumatic instrumentation, install a mist separator on the supply pressure side.
 Note 2) Install a cylinder so that the cylinder rod might not be twisted.
 Note 3) Do not apply force to the protective cover of the feedback spring.
 Note 4) The zero point is subject to the mounting position. Adjust zero point after installation on the site.

- Note 5) Do not use a lubricator.
 Note 6) Cylinder dimensions are the same as those of the CS1 series. For details, refer to the **WEB catalog** or the Best Pneumatics No. 2.
 Note 7) When using the cylinder outdoors, take measures to avoid wind and rain.

Series CPS1

Dimensions

Head flange: CPS1G

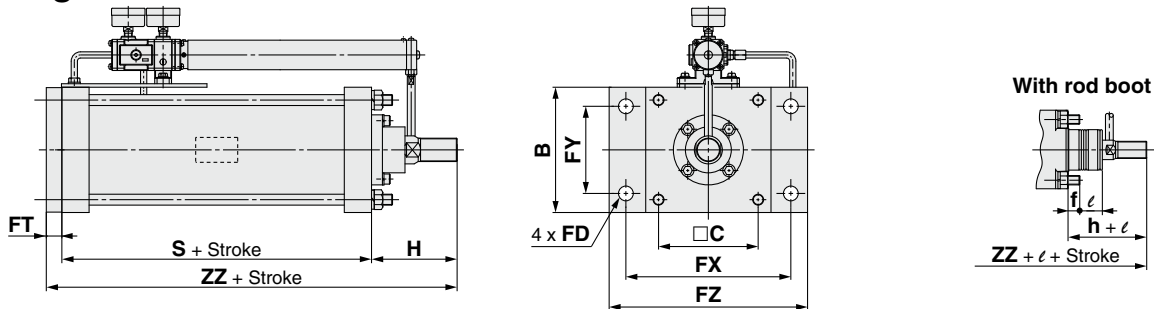

Dimensions

(mm)

Bore size	B	□C	FD	FT	FX	FY	FZ	S	Without rod boot		With rod boot			
									H	ZZ	f	h	ℓ	ZZ
125	145	115	19	14	190	100	230	98	110	235	40	133	0.2 stroke	258
140	160	128	19	20	212	112	255	98	110	235	40	133		258
160	180	144	19	20	236	118	275	106	120	256.5	40	141		277.5
180	200	162	24	25	265	132	320	111	135	281	45	153		299
200	225	182	24	25	280	150	335	111	135	281	45	153		299
250	275	225	29	30	355	180	420	141	160	342.5	55	176	0.17 stroke	358.5
300	330	270	33	30	400	212	475	146	175	372.5	55	190		387.5

Note 1) If the air is not for pneumatic instrumentation, install a mist separator on the supply pressure side.

Note 2) Install a cylinder so that the cylinder rod might not be twisted.

Note 3) Do not apply force to the protective cover of the feedback spring.

Note 4) The zero point is subject to the mounting position. Adjust zero point after installation on the site.

Note 5) Do not use a lubricator.

Note 6) Cylinder dimensions are the same as those of the CS1 series. For details, refer to the **WEB catalog** or the Best Pneumatics No. 2.

Note 7) When using the cylinder outdoors, take measures to avoid wind and rain.

Single clevis: CPS1C

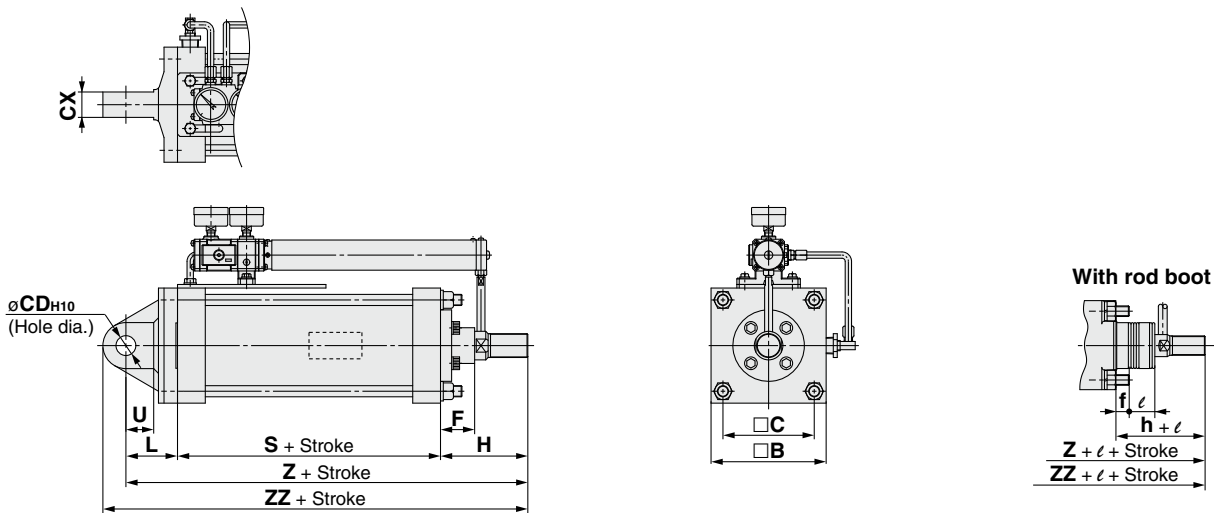

Dimensions

(mm)

Bore size	□B	□C	F	L	S	U	∅CD _{H10}	CX	Without rod boot			With rod boot				
									H	Z	ZZ	f	h	ℓ	Z	ZZ
125	145	115	43	65	98	35	25 ^{+0.084} ₀	32 ^{-0.3} _{-0.1}	110	273	302	40	133	0.2 stroke	296	325
140	161	128	43	75	98	40	28 ^{+0.084} ₀	36 ^{-0.3} _{-0.1}	110	283	315	40	133		306	338
160	182	144	43	80	106	45	32 ^{+0.100} ₀	40 ^{-0.3} _{-0.1}	120	306	342	40	141		327	363
180	204	162	48	90	111	50	40 ^{+0.100} ₀	50 ^{-0.3} _{-0.1}	135	336	380	45	153		354	398
200	226	182	48	90	111	50	40 ^{+0.100} ₀	50 ^{-0.3} _{-0.1}	135	336	380	45	153		354	398
250	277	225	60	110	141	65	50 ^{+0.100} ₀	63 ^{-0.3} _{-0.1}	160	411	466	55	176	0.17 stroke	427	482
300	330	270	60	130	146	80	63 ^{+0.120} ₀	80 ^{-0.3} _{-0.1}	175	451	519	55	190		466	534

Note 1) Use only dehumidified and dust extracted clean compressed air as the air supply.

Note 2) Install a cylinder so that the cylinder rod might not be twisted.

Note 3) Do not apply force to the protective cover of the feedback spring.

Note 4) The zero point is subject to the mounting position. Adjust zero point after installation on the site.

Note 5) Do not use a lubricator.

Note 6) Cylinder dimensions are the same as those of the CS1 series. For details, refer to the **WEB catalog** or the Best Pneumatics No. 2.

Note 7) When using the cylinder outdoors, take measures to avoid wind and rain.

Dimensions

Double clevis: CPS1D

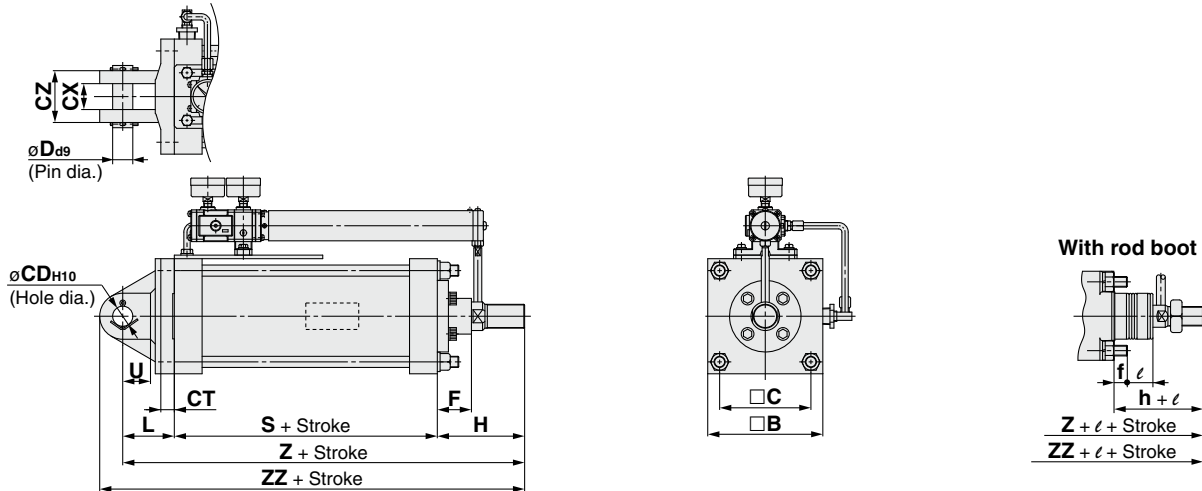

Dimensions

Bore size	□B	□C	F	L	S	U	∅CD _{H10}	CT	CX	CZ	∅D _{d9}	Without rod boot		With rod boot						
												H	Z	ZZ	f	h	ℓ		Z	ZZ
125	145	115	43	65	98	35	25 ^{+0.084} ₀	17	32 ^{+0.3} _{+0.1}	64 ⁻⁰ _{-0.2}	25 ^{-0.065} _{-0.117}	110	273	302	40	133	0.2 stroke	296	325	
140	161	128	43	75	98	40	28 ^{+0.084} ₀	17	36 ^{+0.3} _{+0.1}	72 ⁻⁰ _{-0.2}	28 ^{-0.065} _{-0.117}	110	283	315	40	133		306	338	
160	182	144	43	80	106	45	32 ^{+0.100} ₀	20	40 ^{+0.3} _{+0.1}	80 ⁻⁰ _{-0.2}	32 ^{-0.080} _{-0.142}	120	306	342	40	141		327	363	
180	204	162	48	90	111	50	40 ^{+0.100} ₀	23	50 ^{+0.3} _{+0.1}	100 ^{-0.1} _{-0.3}	40 ^{-0.080} _{-0.142}	135	336	380	45	153		354	398	
200	226	182	48	90	111	50	40 ^{+0.100} ₀	25	50 ^{+0.3} _{+0.1}	100 ^{-0.1} _{-0.3}	40 ^{-0.080} _{-0.142}	135	336	380	45	153	354	398		
250	277	225	60	110	141	65	50 ^{+0.100} ₀	30	63 ^{+0.3} _{+0.1}	126 ^{-0.1} _{-0.3}	50 ^{-0.080} _{-0.142}	160	411	466	55	176	0.17 stroke	427	482	
300	330	270	60	130	146	80	63 ^{+0.120} ₀	37	80 ^{+0.3} _{+0.1}	160 ^{-0.1} _{-0.3}	63 ^{-0.100} _{-0.174}	175	451	519	55	190	466	534		

- Note 1) Use only dehumidified and dust extracted clean compressed air as the air supply.
 Note 2) Install a cylinder so that the cylinder rod might not be twisted.
 Note 3) Do not apply force to the protective cover of the feedback spring.
 Note 4) The zero point is subject to the mounting position. Adjust zero point after installation on the site.

- Note 5) Do not use a lubricator.
 Note 6) Cylinder dimensions are the same as those of the CS1 series. For details, refer to **the WEB catalog** or the Best Pneumatics No. 2.
 Note 7) When using the cylinder outdoors, take measures to avoid wind and rain.

Center trunnion: CPS1T

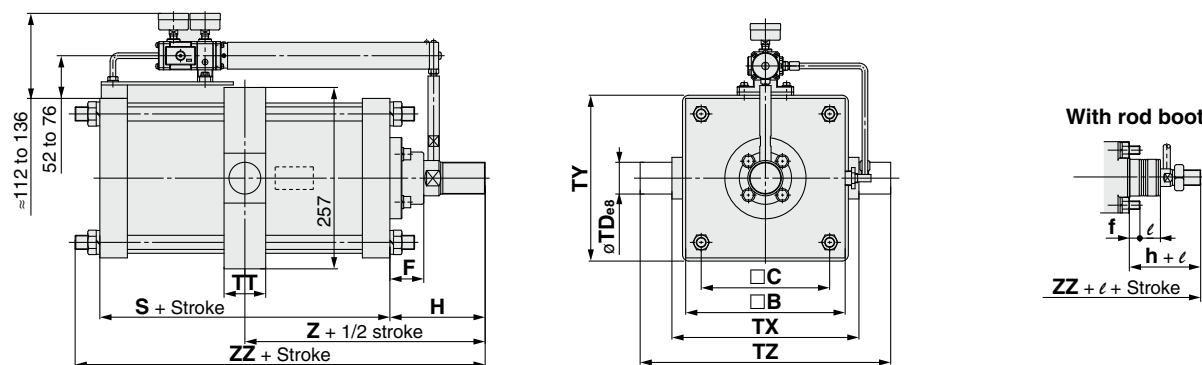

Dimensions

Bore size	□B	□C	F	S	TT	TX	TY	TZ	∅TD _{e8}	Without rod boot		With rod boot						
										H	Z	ZZ	f	h	ℓ		Z	ZZ
125	145	115	43	98	50	170	164	234	32 ^{-0.050} _{-0.089}	110	159	227	40	133	0.2 stroke	182	250	
140	161	128	43	98	55	190	184	262	36 ^{-0.050} _{-0.089}	110	159	227	40	133		182	250	
160	182	144	43	106	60	212	204	292	40 ^{-0.050} _{-0.089}	120	173	248	40	141		194	269	
180	204	162	48	111	59	236	228	326	45 ^{-0.050} _{-0.089}	135	190.5	272	45	153		208.5	290	
200	226	182	48	111	59	265	257	355	45 ^{-0.050} _{-0.089}	135	190.5	272	45	153	208.5	290		
250	277	225	60	141	69	335	325	447	56 ^{-0.060} _{-0.106}	160	230.5	331	55	176	0.17 stroke	246.5	347	
300	330	270	60	146	79	400	390	534	67 ^{-0.060} _{-0.106}	175	248	357	55	190	263.0	372		

- Note 1) If the air is not for pneumatic instrumentation, install a mist separator on the supply pressure side.
 Note 2) Install a cylinder so that the cylinder rod might not be twisted.
 Note 3) Do not apply force to the protective cover of the feedback spring.
 Note 4) The zero point is subject to the mounting position. Adjust zero point after installation on the site.

- Note 5) Do not use a lubricator.
 Note 6) Cylinder dimensions are the same as those of the CS1 series. For details, refer to **the WEB catalog** or the Best Pneumatics No. 2.
 Note 7) When using the cylinder outdoors, take measures to avoid wind and rain.

Series CPA2/CPS1

Dimensions of Accessories

Series CPA2

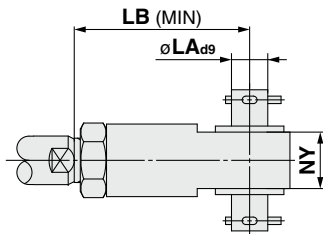

Single knuckle joint assembly

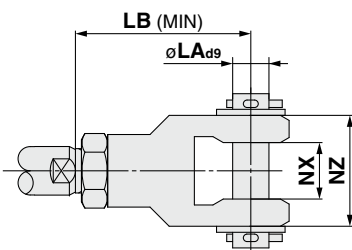

Double knuckle joint assembly

Bore size	Dimensions of accessories				
	ϕLA_{d9}	LB	NX	NY	NZ
50	$12_{-0.050}^{-0.093}$	74	$16_{+0.1}^{+0.3}$	$16_{-0.3}^{-0.1}$	38
63	$12_{-0.050}^{-0.093}$	74	$16_{+0.1}^{+0.3}$	$16_{-0.3}^{-0.1}$	38
80	$18_{-0.050}^{-0.093}$	87	$28_{+0.1}^{+0.3}$	$28_{-0.3}^{-0.1}$	55
100	$20_{-0.065}^{-0.117}$	102	$30_{+0.1}^{+0.3}$	$30_{-0.3}^{-0.1}$	61

* A knuckle pin, split pins and flat washers are included with the double knuckle joint.

Series CPS1

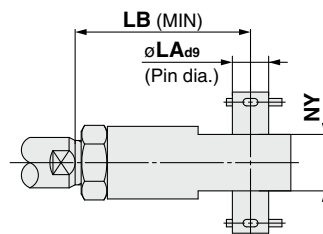

Single knuckle joint

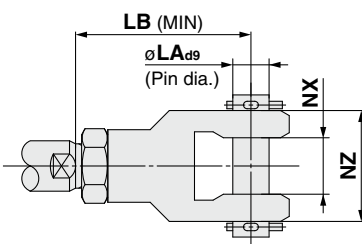

Double knuckle joint assembly

Bore size	Dimensions of accessories				
	ϕLA_{d9}	LB	NX	NY	NZ
125	$25_{-0.117}^{-0.065}$	121	$32_{+0.1}^{+0.3}$	$32_{-0.3}^{-0.1}$	$64_{-0.3}^{-0.1}$
140	$28_{-0.117}^{-0.065}$	126	$36_{+0.1}^{+0.3}$	$36_{-0.3}^{-0.1}$	$72_{-0.3}^{-0.1}$
160	$32_{-0.142}^{-0.080}$	134	$40_{+0.1}^{+0.3}$	$40_{-0.3}^{-0.1}$	$80_{-0.3}^{-0.1}$
180	$40_{-1.142}^{-0.080}$	151	$50_{+0.1}^{+0.3}$	$50_{-0.3}^{-0.1}$	$100_{-0.3}^{-0.1}$
200	$40_{-0.142}^{-0.080}$	155	$50_{+0.1}^{+0.3}$	$50_{-0.3}^{-0.1}$	$100_{-0.3}^{-0.1}$
250	$50_{-0.142}^{-0.080}$	198	$63_{+0.1}^{+0.3}$	$63_{-0.3}^{-0.1}$	$126_{-0.3}^{-0.1}$
300	$63_{-0.174}^{-0.100}$	217	$80_{+0.1}^{+0.3}$	$80_{-0.3}^{-0.1}$	$160_{-0.3}^{-0.1}$

* A pin and split pins are included with the double knuckle joint.

Pneumatic Instrumentation Equipment

Detection Conversion Unit



Pressure Switches/Sensors

Pressure Switch/Micro Switch Type/IS100	Page 75
Pressure Switch/Reed Switch Type/IS10	Page 77
Pressure Switch/Micro Switch Type/IS3000	Page 77
General Purpose Pressure Switch/Snap Switch Type/ISG ...	Page 77
2-Color Display High-Precision Digital Pressure Switch/ZSE/ISE30A ...	Page 77
2-Color Display Digital Pressure Switch/ISE70/75(H)	Page 77
2-Color Display Digital Pressure Switch/ZSE/ISE80	Page 77

Flow Switches/Sensors

2-Color Display Digital Flow Switch/PFM	Page 78
2-Color Display Digital Flow Switch/PFMB	Page 78
Digital Flow Switch for Air/PF2A	Page 78
3-Color Display Digital Flow Switch for Water/PF3W	Page 78
3-Color Display Electromagnetic Type Digital Flow Switch/LFE□ ...	Page 78
Diaphragm Style Flow Switch/IFW5	Page 78
Paddle Style Flow Switch/IF3	Page 78

Pressure Switch/ Micro Switch Type Series IS100

- The pressure switch IS100 series can be utilized for automatic air pressure control in a wide variety of fields, such as industrial machinery or chemical plant.

Pressure adjustment range: 0.02 to 0.1 MPa

Electric wiring: Various wiring and entry methods can be selected.

Mechanical service life: 100,000 cycles

How to Order

IS 1 00 - 02

Pressure switch • Port size Rc1/4

• Specifications

00	3-pin plug and socket
01	External terminals
12	Enclosed terminals

IS 1 13 - 02 - 04

Pressure switch • Port size Rc1/4

• Electrical entry

04	15a, G1/2
06	20a, G3/4

• Specifications

13	Enclosed terminals	With cable gland
14	Enclosed terminals	Female threaded

Specifications

Model	IS100-02	IS101-02	IS112-02	IS113-02-□□	IS114-02-□□
Proof pressure	0.2 MPa				
Pressure adjustment range	0.02 to 0.1 MPa				
Hysteresis	0.0015 MPa or less				
Repeatability	±5% F.S.				
Fluid	Air				
Ambient and fluid temperature	-5 to 60°C (No freezing)				
Port size	Rc1/4				
Rated voltage	125/250 VAC 5A, 30 VDC 5A				
Mechanical service life	100,000 cycles				

Symbol

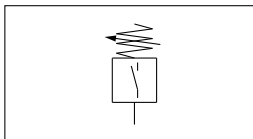

Electrical circuit IS100

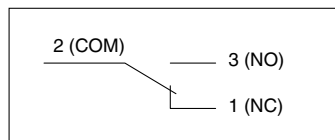

Other

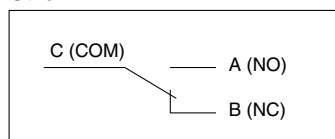

Construction/Principle of Operation

Signal pressure enters the chamber above diaphragm ① and exerts downward force compressing spring ②. After sufficient deflection, contact with the plunger of the micro switch ③ is made operating the electrical circuit. As overtravel of diaphragm is prevented by an internal stop, the micro switch is not subject to extra load with increased pressure. On decrease of signal pressure the electrical circuit function is reversed. Contacts are available for N.C. or N.O. operation. Adjustment is carried out by removing cap ④ and rotating adjusting screw as required changing spring load.

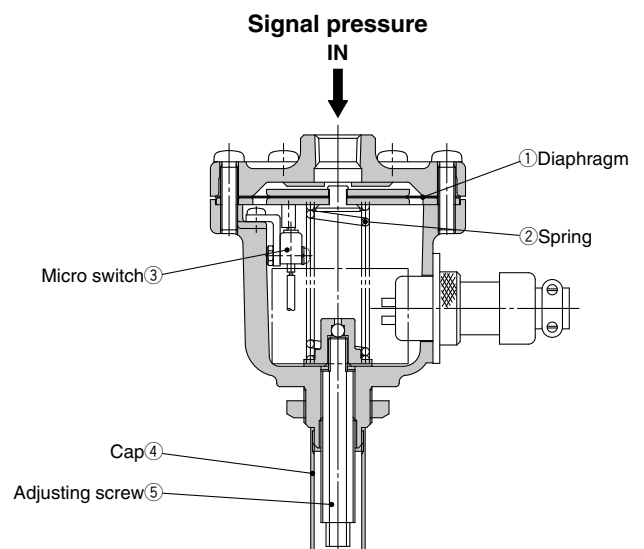

Dimensions

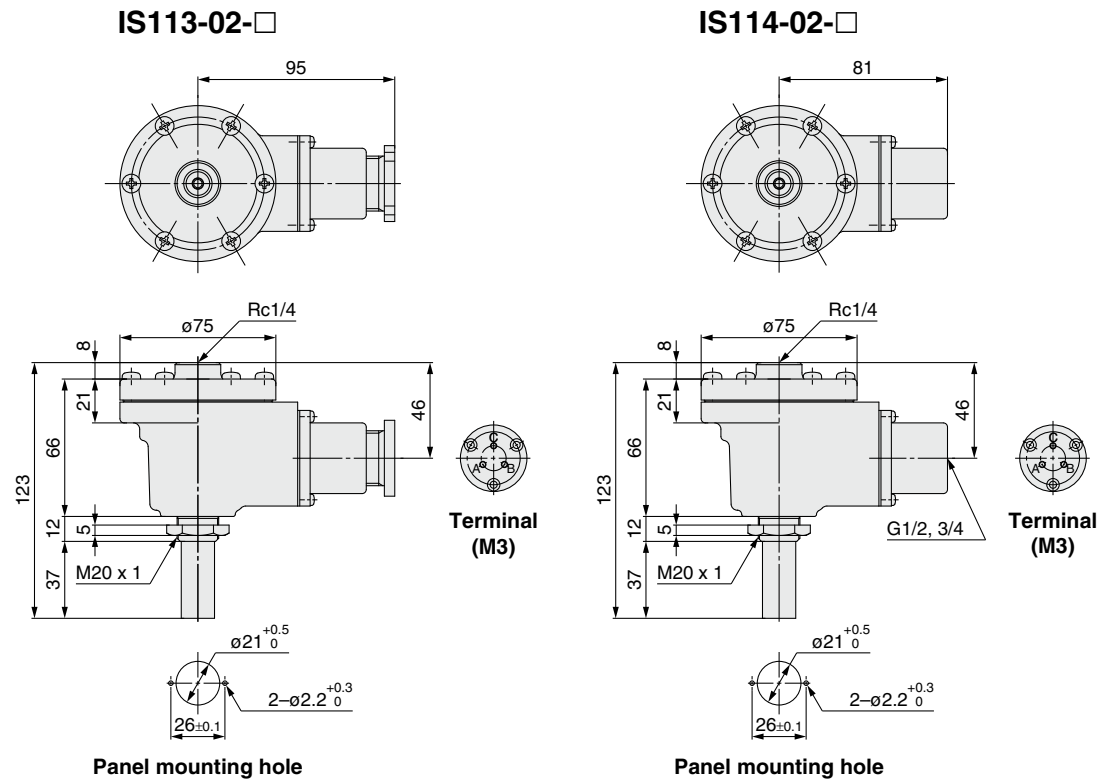
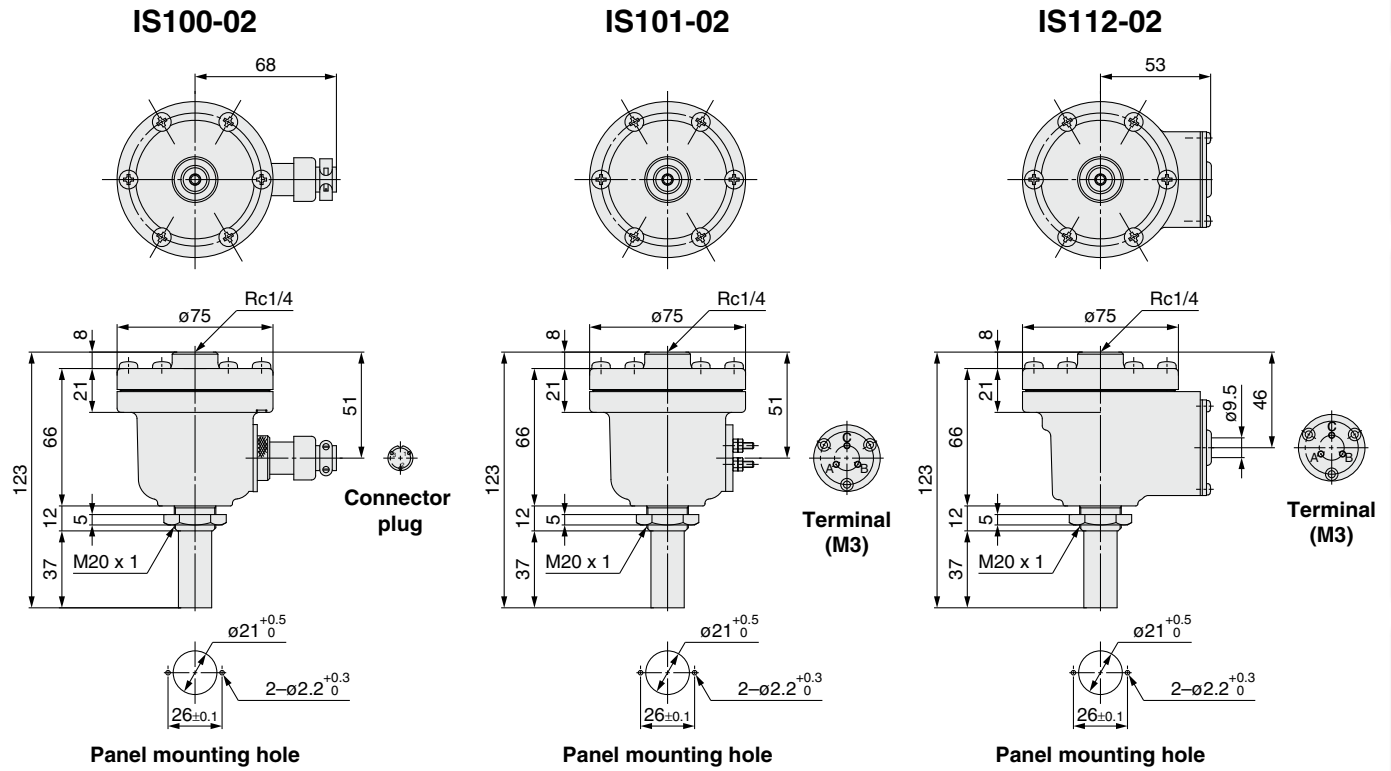

Positioners

Regulators

Relays/Valves

Electro-Pneumatic Transducers

Actuators

Detection Conversion Unit

Solenoid Valves

Air Preparation Equipment

Industrial Filters

Piping Materials

Pressure Switches/Sensors

Best Pneumatics

Pressure Switch/Reed Switch Type **IS10**

- Small (Overall height 52 mm, Width 15 mm)



Series	Type	Set pressure range	Contact
IS10	Positive pressure	0.1 to 0.4 MPa 0.1 to 0.6 MPa	Reed switch 1a

Pressure Switch/Micro Switch Type **IS3000**

- Can be used for micro load around 10 mA.
- With neon light



Series	Type	Set pressure range	Contact
IS3000	Positive pressure	0.1 to 0.7 MPa	Micro switch 1ab

General Purpose Pressure Switch/Snap Switch Type **ISG**

- For general fluids
- Equivalent to IP44 (ISG2*□)
- With indicator light (IS2761)
- With hysteresis adjusting function



Series	Type	Set pressure range	Contact
ISG11□, 21□	Positive pressure	0.02 to 0.3 MPa	Snap switch 1a1b 2ab
ISG12□, 22□	Positive pressure	0.05 to 0.7 MPa	
ISG13□, 23□	Positive pressure	0.1 to 1.0 MPa	
ISG19□, 29□	Vacuum pressure	-10 to -100 kPa	1ab (Light 1b)
IS2761	Positive pressure	0.1 to 1.0 MPa	

2-Color Display High-Precision Digital Pressure Switch **ZSE/ISE30A**

- With One-touch fitting (Straight, Elbow)
- Space-saving, Mountable side by side without clearance
- With display calibration function
- Can copy to up to 10 switches simultaneously.



Series	Type	Rated pressure range
ZSE30AF	Compound pressure	-100.0 to 100.0 kPa
ZSE30A	Vacuum pressure	0.0 to -101.0 kPa
ISE30A	Positive pressure	-0.100 to 1.000 MPa

2-Color Display Digital Pressure Switch **ISE70/75(H)**

- Metal body type (Aluminum die-casted)
- IP67
- With M12 connector



Series	Type	Rated pressure range
ISE70	Positive pressure (for air)	0 to 1 MPa
ISE75	Positive pressure (for general fluids)	0 to 10 MPa
ISE75H	Positive pressure (for general fluids)	0 to 15 MPa

2-Color Display Digital Pressure Switch **ZSE/ISE80**

- Suitable for a wide variety of fluids with stainless steel diaphragm
- IP65
- Low leakage. VCR®, Swagelok® compatible fittings can be selected.
- Rear ported, bottom ported



Series	Type	Rated pressure range
ZSE80F	Compound pressure	-100.0 to 100.0 kPa
ZSE80	Vacuum pressure	0.0 to -101.0 kPa
ISE80	Positive pressure	-0.100 to 1.000 MPa
ISE80H	Positive pressure	-0.100 to 2.000 MPa

Flow Switches/Sensors Best Pneumatics

2-Color Display Digital Flow Switch PFM

- Switch output, accumulated pulse output, analog output
- Grease-free
- 3-step setting
- Integrated flow adjustment valve
- Compact, lightweight, space-saving
- Panel mount, DIN rail, bracket, direct mounting

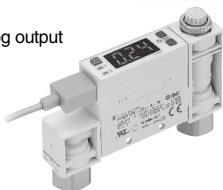

Series	Rated flow range (L/min)
PFM	0.2 to 10 (0.2 to 5)
	0.5 to 25 (0.5 to 12.5)
	1 to 50 (1 to 25)
	2 to 100 (2 to 50)
(): For CO ₂	

Flow Switches/Sensors

2-Color Display Digital Flow Switch PFMB

- Air, N₂
- Grease-free
- Integrated flow adjustment valve (200 L type only)
- Compact and space-saving



Series	Rated flow range (L/min)
PFMB	2 to 200
	5 to 500
	10 to 1000

Flow Switches/Sensors

Digital Flow Switch for Air PF2A

- Switch output, accumulated pulse output, analog output
- IP65



Series	Rated flow range (L/min)
PF2A	1 to 10
	5 to 50
	10 to 100
	20 to 200
	50 to 500
	150 to 3000
	300 to 6000
600 to 12000	

Best Pneumatics

3-Color Display Digital Flow Switch for Water PF3W

- 3-color/2-screen display
- Integrated flow adjustment valve and temperature sensor (4 L, 16 L, 40 L type only)
- 3-step setting
- 40% smaller than existing product (compared to PF2W)
- IP65 compliant, non-grease type
- Fluid temperature: 0 to 90°C
- Switch output, accumulated pulse output, analog output
- PVC piping type (10 to 100, 30 to 250 L/min only)

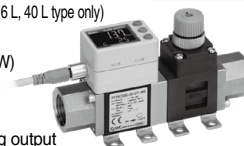

Series	Rated flow range (L/min)
PF3W	0.5 to 4
	2 to 16
	5 to 40
	10 to 100
	50 to 250 (30 to 250)

(): For PVC piping type

Flow Switches/Sensors

3-Color Display Electromagnetic Type Digital Flow Switch LFE□

- Compact, lightweight
56 mm x 40 mm x 90 mm (H x W x D)
Weight: 340 g (LFE1□3)
- Reverse flow can be detected.
- Fluid temperature: 0 to 85°C
- Current consumption: 45 mA
- Applicable fluids: Water, water-soluble coolant



Series	Rated flow range (L/min)
LFE□	0.5 to 20
	2.5 to 100
	5 to 200

Flow Switches/Sensors Best Pneumatics

Diaphragm Style Flow Switch IFW5

- Used as a general relaying device when water stoppage or water volume reduction occurs during the use of a cooling water system, etc.
- With neon light



Series	Set flow rate range (L/min)	Contact
IFW5	1 to 10	Micro switch 1ab
	10 to 20	
	20 to 50	

Flow Switches/Sensors Best Pneumatics

Paddle Style Flow Switch IF3

- Used as a general relaying device when water stoppage or water volume reduction occurs during the use of a cooling water system, etc.
- Port size 3/4, 1
- Equivalent to IP42 and IP44



Series	Set flow rate range (L/min)	Contact
IF3	14 to 60	Micro switch 1ab
	20 to 1500	
	36 to 2600	

Positioners

Regulators

Relays/Valves

Electro-Pneumatic Transducers

Actuators

Detection Conversion Unit

Solenoid Valves

Air Preparation Equipment

Industrial Filters

Piping Materials

Pneumatic Instrumentation Equipment

Solenoid Valves



Directional Control Valves

NAMUR Interface 3 Port Solenoid Valve/VFN200N Page 80

NAMUR Interface 5 Port Solenoid Valve/VFN2000N Page 83

NAMUR Interface 3/5 Port Solenoid Valve/
IP67 Compliant, Hygienic Design Type/
VFN2120N-X23/-X36 Page 90

Intrinsically Safe Explosion-proof System 5 Port Solenoid Valve/51-SY ... Page 96

Explosion-proof Type 3/5 Port Solenoid Valve/50-VFE/50-VPE ... Page 96

Fluid Control Equipment

Direct Operated 2 Port Solenoid Valve/VX2 Page 96

Pilot Operated 2 Port Solenoid Valve/VXD Page 96

NAMUR Interface 3 Port Solenoid Valve

Series VFN200N

The interface surface complies with NAMUR.

- Can be directly installed on the industrial valve actuator that complies with NAMUR.



How to Order

VFN212 N - 5 D Z - 02 F - - -

NAMUR Interface

CE marking

Voltage

1	100 VAC, 50/60 Hz
2	200 VAC, 50/60 Hz
3	110 to 120 VAC, 50/60 Hz
4	220 VAC, 50/60 Hz
5	24 VDC
6	12 VDC
7	240 VAC, 50/60 Hz

For other rated voltages, please contact SMC.

Electrical entry

G	Grommet
E	Grommet terminal
T	Conduit terminal
D	DIN terminal
DO	DIN terminal (Without connector)
Y ^{Note)}	DIN terminal
Y0 ^{Note)}	DIN terminal (Without connector)

Note) Conforming to DIN 43650, Form B

Thread type

Nil	Rc (PT)
F	G (PF)
N	NPT

Solenoid

Nil	Single solenoid
D	Double solenoid

Manual override

Nil	Non-locking push type (Flush)
A	Non-locking push type (Extended)
B	Locking type (Tool required)

Light/Surge voltage suppressor

Nil	None
Z	With light/surge voltage suppressor
S ^{Note)}	With surge voltage suppressor

Note) Available for grommet type only.

Specifications

Symbol
Single solenoid

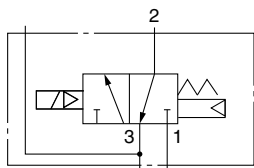

Double solenoid

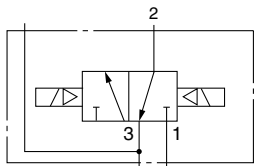

Valve specifications	Fluid	Air, Inert gas		
	Valve type	Normally closed		
	Max. operating pressure	0.9 MPa (130 psi)		
	Min. operating pressure	0.15 MPa (22 psi)		
	Ambient and fluid temperature	-10 to +60°C Note 1)		
	Lubrication	Not required Note 2)		
	Pilot valve manual override	Non-locking push type (Flush)		
	Enclosure	Dustproof		
	Port size	1/4		
	Cv factor (Effective area)	Refer to "Flow-rate Characteristics" table below.		
Weight	Refer to "Weight" table below.			
Other	Cylinder ports should be NAMUR hole pattern.			
Electrical specifications	Coil rated voltage	12, 24 VDC, 100, 110 to 120, 200, 220, 240 VAC (50/60 Hz)		
	Allowable voltage fluctuation	-15 to +10% of rated voltage		
	Coil insulation type	Class B or equivalent		
	Apparent power AC (Power consumption)	Inrush	5.0 VA/60 Hz, 5.6 VA/50 Hz	
		Holding	2.3 VA (1.5 W)/60 Hz, 3.4 VA (2.1 W) 9/50 Hz	
Power consumption DC	1.8 W			
Electrical entry	Grommet, Grommet terminal, Conduit terminal, DIN terminal			

Note 1) Use dry-air at low temperature.

Note 2) Use turbine oil No.1 (ISO VG32), if lubricated.

Flow-rate Characteristics

		Flow-rate characteristics					
		1→4/2 (P→A/B)			4/2→5/3 (A/B→EA/EB)		
		C	b	Cv	C	b	Cv
2-position	Single solenoid	2.68	0.40	0.72	5.41	0.31	1.38
	Double solenoid	2.68	0.40	0.72	5.41	0.31	1.38

Weight

Model	Weight
VFN212N-5D-02F	240
VFN212N-5D-02F-D	380

(g)

Series VFN200N

Dimensions

DIN terminal

VFN212N-□^D(Y)□□-02□-□

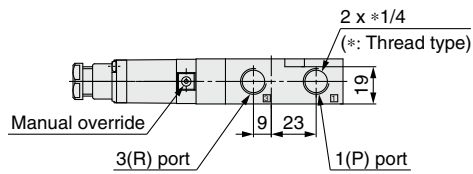
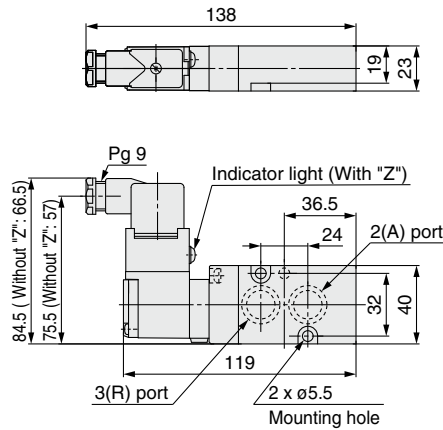
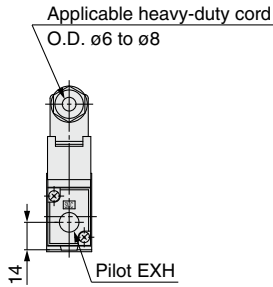

DIN terminal

VFN212N-□^D(Y)□□-02□-D-□

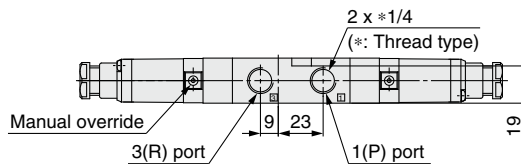
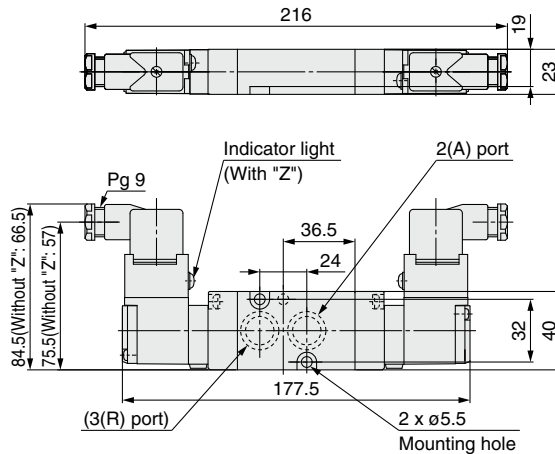
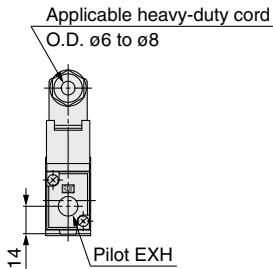

Grommet

VFN212N-□G□□-02□-□-□

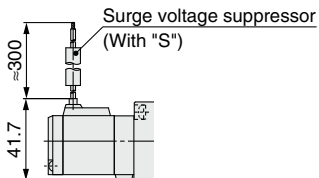

Conduit terminal

VFN212N-□T□□-02□-□-□

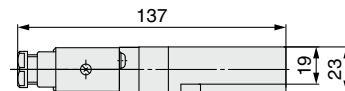

Grommet terminal

VFN212N-□E□□-02□-□-□

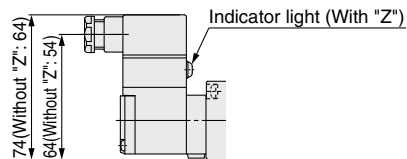
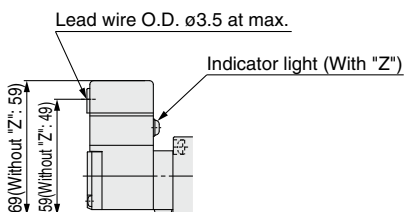

NAMUR Mounting Pattern

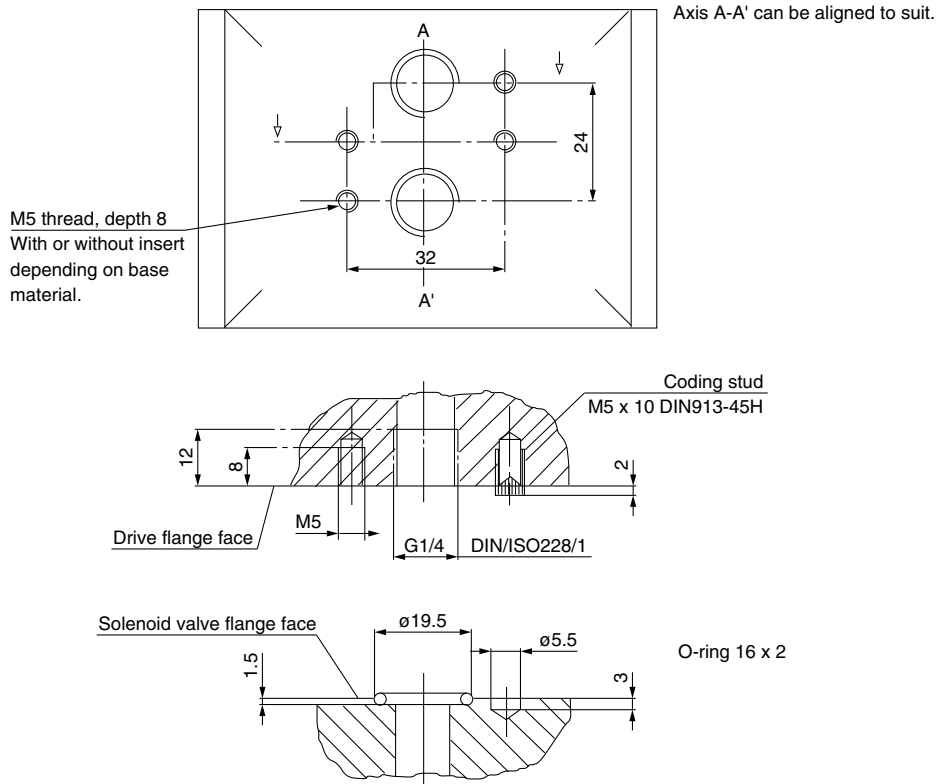

The solenoid valve can be attached with 2 mounting bolts.
The positioning of the coding stud hole is left up to the manufacturer and thus also determines the location of the coding stud.

Positioners

Regulators

Relays/Valves

Electro-Pneumatic
Transducers

Actuators

Detection
Conversion Unit

Solenoid Valves

Air Preparation
Equipment

Industrial Filters

Piping Materials

NAMUR Interface 5 Port Solenoid Valve

Series VFN2000N

The interface surface complies with NAMUR.

- Can be directly installed on the industrial valve actuator that complies with NAMUR.



How to Order

VFN2 **1** **20** - **N** - **5** **D** **Z** **□** - **02** **F** - **□**

Solenoid

1	Single solenoid
2	Double solenoid

NAMUR Interface

Voltage

1	100 VAC, 50/60 Hz
2	200 VAC, 50/60 Hz
3	110 to 120 VAC, 50/60 Hz
4	220 VAC, 50/60 Hz
5	24 VDC
6	12 VDC
7	240 VAC, 50/60 Hz

For other rated voltages, please contact SMC.

Electrical entry

G	Grommet
E	Grommet terminal
T	Conduit terminal
D	DIN terminal
DO	DIN terminal (Without connector)
Y ^{Note)}	DIN terminal
YO ^{Note)}	DIN terminal (Without connector)

Note) Conforming to DIN 43650, Form B

Thread type

Nil	Rc (PT)
F	G (PF)
N	NPT

CE marking

Nil	—
Q	CE marked product

Manual override

Nil	Non-locking push type (Flush)
A	Non-locking push type (Extended)
B	Locking type (Tool required)

Light/Surge voltage suppressor

Nil	None
Z	With light/surge voltage suppressor
S ^{Note)}	With surge voltage suppressor

Note) Available for grommet type only.

Symbol

Single solenoid

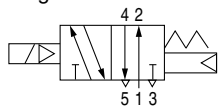

Double solenoid

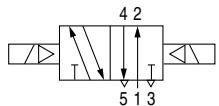

Specifications

Valve specifications	Fluid	Air, Inert gas		
	Max. operating pressure	0.9 MPa (130 psi)		
	Min. operating pressure	0.15 MPa (22 psi)		
	Ambient and fluid temperature	-10 to +60°C Note 1)		
	Lubrication	Not required Note 2)		
	Pilot valve manual override	Non-locking push type (Flush)		
	Enclosure	Dustproof		
	Port size	1/4		
	Cv factor (Effective area)	Refer to "Flow-rate Characteristics" table below.		
	Weight	Refer to "Weight" table below.		
Other	Cylinder ports should be NAMUR hole pattern.			
Electrical specifications	Coil rated voltage	12, 24 VDC, 100, 110 to 120, 200, 220, 240 VAC (50/60 Hz)		
	Allowable voltage fluctuation	-15 to +10% of rated voltage		
	Coil insulation type	Class B or equivalent		
	Apparent power AC (Power consumption)	Inrush	5.0 VA/60 Hz, 5.6 VA/50 Hz	
		Holding	2.3 VA (1.5 W)/60 Hz, 3.4 VA (2.1 W) 9/50 Hz	
Power consumption DC	1.8 W			
Electrical entry	Grommet, Grommet terminal, Conduit terminal, DIN terminal			

Note 1) Use dry-air at low temperature.

Note 2) Use turbine oil No.1 (ISO VG32), if lubricated.

Flow-rate Characteristics

		Flow-rate characteristics					
		1→4/2 (P→A/B)			4/2→5/3 (A/B→EA/EB)		
		C	b	Cv	C	b	Cv
2-position	Single solenoid	3.48	0.25	0.85	4.57	0.17	1.06
	Double solenoid	3.48	0.25	0.85	4.57	0.17	1.06

Weight

Model	Weight (g)
VFN2120N-5D-02F	260
VFN2220N-5D-02F	400

Dimensions

DIN terminal

VFN2120N-□^D(Y)□□-02□-□

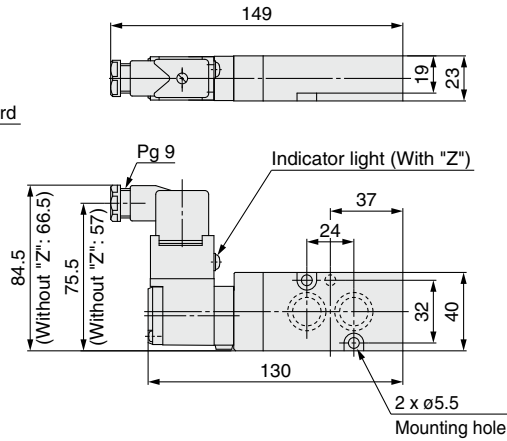
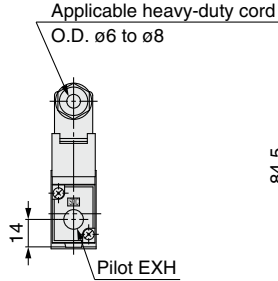

3 x Rc, G, NPT1/4
<1(P), 5(R1), 2(R2) port>

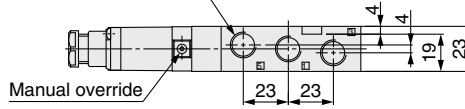

DIN terminal

VFN2220N-□^D(Y)□□-02□-□

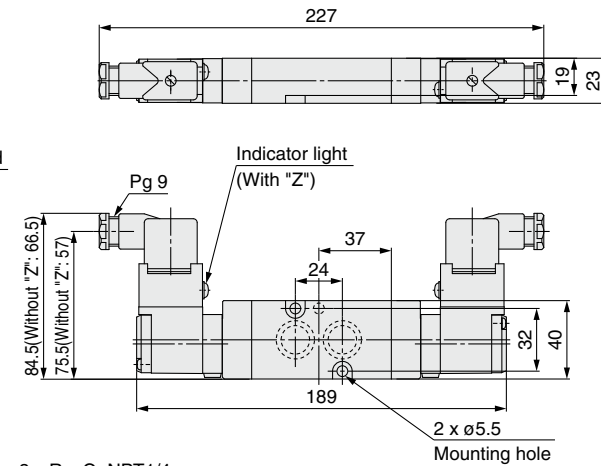
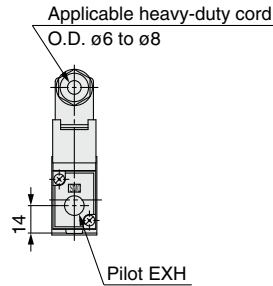

3 x Rc, G, NPT1/4
<1(P), 5(R1), 2(R2) port>

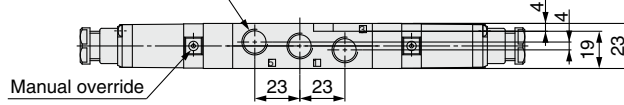

Grommet

VFN2120N-□G□□-02□-□

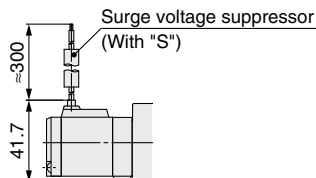

Conduit terminal

VFN2120N-□T□□-02□-□

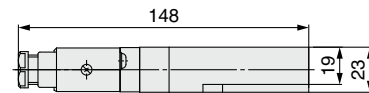

Grommet terminal

VFN2120N-□E□□-02□-□

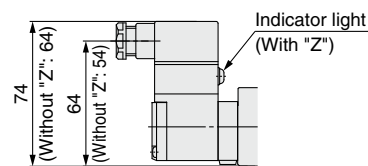
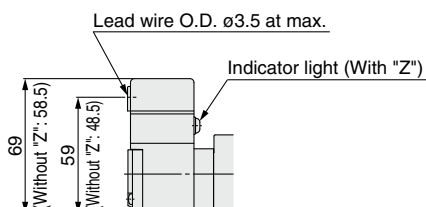

Series VFN2000N

NAMUR Mounting Pattern

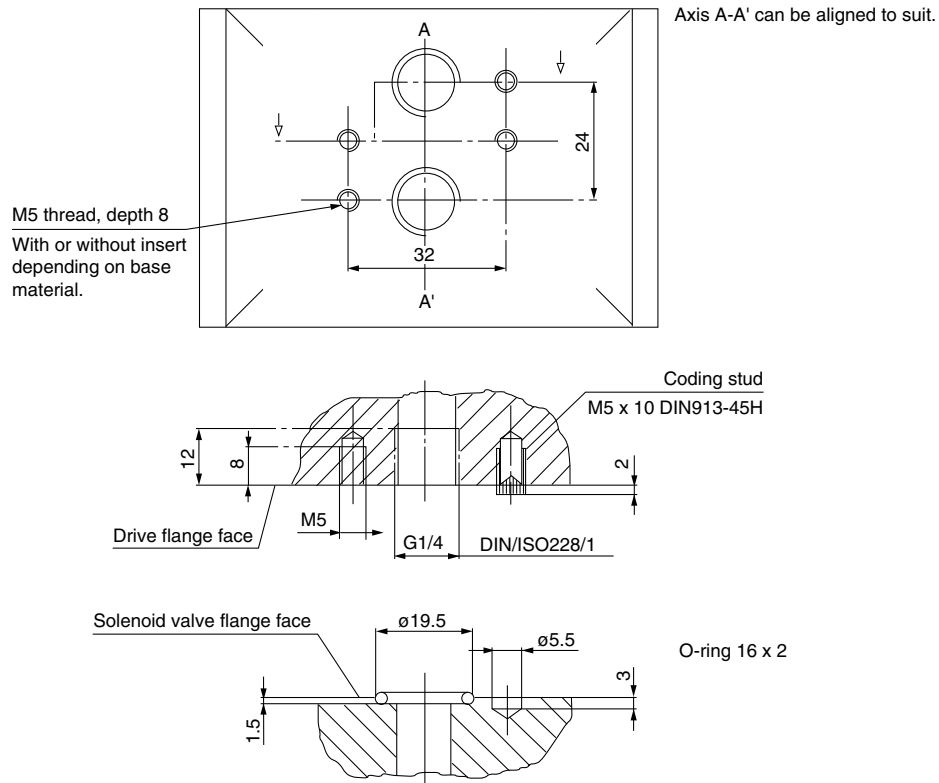

The solenoid valve can be attached with 2 mounting bolts.
The positioning of the coding stud hole is left up to the manufacturer and thus also determines the location of the coding stud.

How to Order Pilot Valve

SF4 - 5 D Z - 12 - X99

Coil rated voltage

1	100 VAC, 50/60 Hz
2	200 VAC, 50/60 Hz
3	110 to 120 VAC, 50/60 Hz
4	220 VAC, 50/60 Hz
5	24 VDC
6	12 VDC
7	240 VAC, 50/60 Hz

For other rated voltages, please contact SMC.

Electrical entry

G	Grommet
E	Grommet terminal
T	Conduit terminal
D	DIN terminal
DO	DIN terminal (Without connector)
Y ^{Note)}	DIN terminal
Y0 ^{Note)}	DIN terminal (Without connector)

Note) Conforming to DIN 43650, Form B

Manual override

Nil	Non-locking push type (Flush)
A	Non-locking push type (Extended)
B	Locking type (Tool required)

Light/Surge voltage suppressor

Nil	None
Z	With light/surge voltage suppressor
S ^{Note)}	With surge voltage suppressor

Note) Available for grommet type only. Grommet type is available only with surge voltage suppressor, not with indicator light.

Pilot valve assembly for VFN200N/VFN2000N



NAMUR Interface Solenoid Valves Specific Product Precautions 1

Be sure to read this before handling.

Design

Warning

1. Actuator drive

When an actuator, such as a cylinder, is to be driven using a valve, take appropriate measures to prevent potential danger caused by actuator operation.

2. Holding pressure (including vacuum)

Since the valves are subject to air leakage, they cannot be used for applications such as holding pressure (including vacuum) in a pressure vessel.

3. Not suitable for use as an emergency shutoff valve, etc.

The valves are not designed for safety applications such as an emergency shutoff valve. If the valves are used for the mentioned applications, additional safety measures should be adopted.

4. Ensure sufficient space for maintenance activities.

When installing the products, allow access for maintenance.

5. Release of residual pressure

For maintenance purposes install a system for releasing residual pressure.

Selection

Warning

1. Confirm the specifications.

Products are designed only for use in compressed air systems (including vacuum). Do not operate at pressures or temperatures, etc., beyond the range of specifications, as this can cause damage or malfunction. (Refer to the specifications.) Please contact SMC when using a fluid other than compressed air (including vacuum).

2. Extended periods of continuous energization

Please contact SMC when a valve is continuously energized for an extended period of time or when the energized period is longer than the de-energized period.

Caution

1. Momentary energization (Double solenoid valve)

If a double solenoid valve is operated with momentary energization, it should be energized for at least 0.1 second. However, depending on the condition of the secondary load, it should be energized until the cylinder reaches the stroke end position, since there is a possibility of malfunction.

Selection

Caution

2. Leakage voltage

Take note that the leakage voltage will increase when a C-R circuit (surge voltage suppressor) is used for protecting a switching device because of the passing leakage voltage through the C-R circuit.

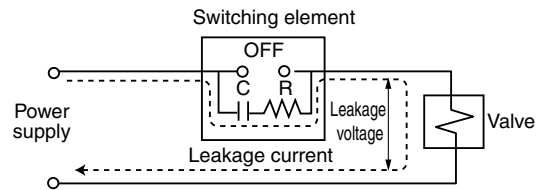

The suppressor residual leakage voltage should be as follows.
DC coil: 3% or less of rated voltage
AC coil: 20% or less of rated voltage

3. Solenoid valve drive with SSR

If the minimum load current of the SSR is larger than that of the solenoid valve, this may cause a malfunction.

When selecting the SSR, refer to the element catalog specifications.

4. Surge voltage suppressor

If a surge protection circuit contains nonstandard diodes, such as Zener diodes or ZNR, a residual voltage that is in proportion to the protective circuit and the rated voltage will remain. Therefore, take into consideration the surge voltage protection of the controller.

In the case of diodes, the residual voltage is approximately 1 V.

5. Operation in a low temperature condition

It is possible to operate a valve in extreme temperature, as low as -10°C . Take appropriate measures to avoid freezing of drainage, moisture etc. in low temperature.

6. Mounting orientation

Mounting orientation of a single solenoid valve is universal. When installing a double solenoid valve, mount the valve so that spool valve is horizontal.

Mounting

Warning

1. If air leakage increases or equipment does not operate properly, stop operation.

Check mounting conditions when air and power supplies are connected. Initial function and leakage tests should be performed after installation.

2. Operation manual

Install the products and operate them only after reading the operation manual carefully and understanding its contents. Also, keep the manual where it can be referred to as necessary.

3. Painting and coating

Warnings or specifications printed or affixed to the product should not be erased, removed or covered up. Also, applying paint to resinous parts may have an adverse effect due to the solvent in the paint.

Positioners

Regulators

Relays/Valves

Electro-Pneumatic Transducers

Actuators

Detection Conversion Unit

Solenoid Valves

Air Preparation Equipment

Industrial Filters

Piping Materials



NAMUR Interface Solenoid Valves

Specific Product Precautions 2

Be sure to read this before handling.

Piping

⚠ Caution

1. Preparation before piping

Before piping is connected, it should be thoroughly blown out with air (flushing) or washed to remove chips, cutting oil and other debris from inside the pipe.

2. Wrapping of sealant tape

When screwing piping or fittings into ports, ensure that chips from the pipe threads or sealing material do not enter the piping. Also, if sealant tape is used, leave 1.5 to 2 thread ridges exposed at the end of the threads.

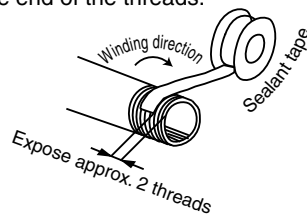

3. Connection of fittings

When attaching fittings to valves, tighten with the tightening torque shown below.

Connection thread size	Proper tightening torque N·m(kgf·cm)
1/4	12 to 14 (120 to 140)

4. Piping to products

When piping to a product, refer to the operation manual to avoid mistakes regarding the supply port, etc.

Wiring

⚠ Caution

1. Applied voltage

When electric power is connected to a solenoid valve, be careful to apply the proper voltage. Improper voltage may cause malfunction or coil damage.

2. Check the connections.

Check if the connections are correct after completing all wiring.

Light/Surge Voltage Suppressor

⚠ Caution

AC and 100 VDC

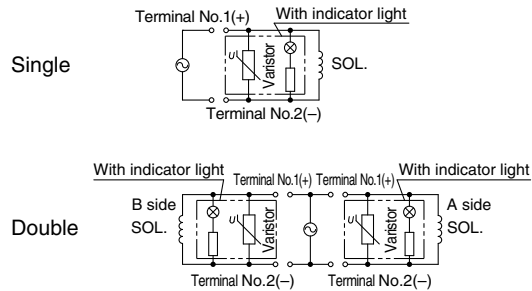

24 VDC or less

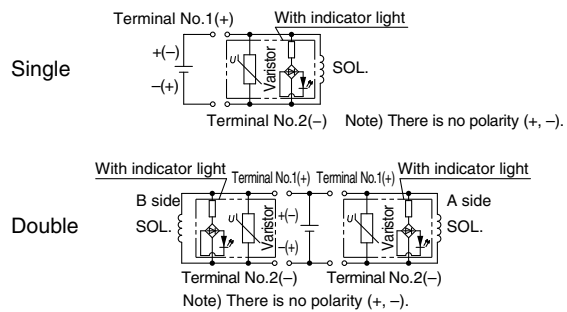

•Type G: Use lead wire from solenoid to connect with power side. Grommet with DC voltage surge voltage suppressor has polarity. Connect red lead wire to + (positive) side and black to - (negative) side.

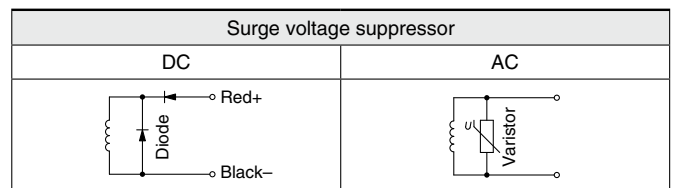

Wiring

⚠ Caution

In the case of DIN terminal and terminal block (with indicator light/surge voltage suppressor), the interior wiring is shown below.

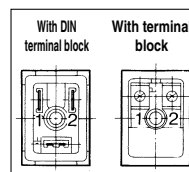

Applicable terminal: 1.25-3, 1.25-3S, 1.25Y-3N, 1.25Y-3S, but in the case of with DIN terminal block, is not a terminal structure.

Note) There is no polarity (+, -).



NAMUR Interface Solenoid Valves

Specific Product Precautions 3

Be sure to read this before handling.

Changing Direction of DIN Terminal/Cable Entry

⚠ Caution

To change direction of DIN terminal retaining screw, pull off outer cover, rotate connector board through 180°. Replace cover and tighten screw.

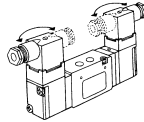

Lubrication

⚠ Caution

1. Lubrication

- 1) The valve has been lubricated for life at the factory, and does not require any further lubrication.
- 2) If a lubricant is used in the system, use class 1 turbine oil (no additive), ISO VG32. Once a lubricant is used in the system, lubrication must be continued because the original lubricant applied during manufacturing will be washed away. Refer to each manufacturer's brand name of class 1 turbine oil (no additive), ISO VG32 as shown below.

Class 1 Turbine Oil (No additive), ISO VG32

Classification of viscosity cst (40C)	Viscosity according to ISO Grade	32
Idemitsu Kosan Co., Ltd.	Turbine oil P-32	
Nippon Oil Corporation	Turbine oil 32	
COSMO OIL CO., LTD.	Cosmo turbine 32	
Japan Energy Corporation	Kyodo turbine 32	
Kygnus Sekiyu K.K.	Turbine oil 32	
Kyushu Oil Co., Ltd.	Stork turbine 32	
Mitsubishi Oil Co., Ltd.	Mitsubishi turbine 32	
SHOWA SHELL SEKIYU K.K.	Turbine 32	
Tonen General Sekiyu K.K.	General R turbine 32	
FUJI KOSAN CO., LTD.	Fukkol turbine 32	

Please contact SMC for details about class 2 turbine oil (with additives), ISO VG32.

Air Supply

⚠ Warning

1. Use clean air.

Do not use compressed air that contains chemicals, synthetic oils including organic solvents, salt or corrosive gases, etc., as it can cause damage or malfunction.

⚠ Caution

1. Install an air filter.

Install an air filter upstream near the valve. Select an air filter with a filtration size of 5 µm or smaller.

Air Supply

⚠ Caution

2. Take measures to ensure air quality, such as by installing an aftercooler, air dryer, or water separator.

Compressed air that contains a large amount of drainage can cause malfunction of pneumatic equipment such as valves. Therefore, take appropriate measures to ensure air quality, such as by providing an aftercooler, air dryer, or water separator.

3. If excessive carbon powder is seen, install a mist separator on the upstream side of the valve.

If excessive carbon dust is generated by the compressor, it may adhere to the inside of a valve and cause it to malfunction.

For compressed air quality, refer to SMC Best Pneumatics catalog.

Operating Environment

⚠ Warning

1. Do not use in an atmosphere having corrosive gases, chemicals, sea water, water, water steam, or where there is direct contact with any of these.

2. Do not use in explosive atmospheres.

3. Do not use in a place subject to heavy vibration and/or impact.

Confirm the specifications in the main section of the catalog.

4. The valve should not be exposed to prolonged sunlight. Use a protective cover.

5. Remove any sources of excessive heat.

6. In locations where there is contact with spatter from water, oil, solder, etc., take suitable protective measures.

7. When the solenoid valve is mounted in a control panel or its energized for a long time, make sure ambient temperature is within the specification of the valve.

Positioners

Regulators

Relays/Valves

Electro-Pneumatic Transducers

Actuators

Detection Conversion Unit

Solenoid Valves

Air Preparation Equipment

Industrial Filters

Piping Materials



NAMUR Interface Solenoid Valves

Specific Product Precautions 4

Be sure to read this before handling.

Maintenance

Warning

1. Perform maintenance inspection according to the procedures indicated in the operation manual.

If handled improperly, malfunction and damage of machinery or equipment may occur.

2. Removal of equipment, and supply/exhaust of compressed air

When components are removed, first confirm that measures are in place to prevent workpieces from dropping, run-away equipment, etc. Then, cut off the supply pressure and electric power, and exhaust all compressed air from the system using the residual pressure release function. For 3-position closed center type, exhaust the residual pressure between the valve and the cylinder.

When the equipment is operated after remounting or replacement, first confirm that measures are in place to prevent lurching of actuators, etc. Then, confirm that the equipment is operating normally.

3. Low frequency operation

Valves should be operated at least once every 30 days to prevent malfunction. (Use caution regarding the air supply.)

4. Manual override

When the manual override is operated, connected equipment will be actuated. Operate after safety is confirmed.

Caution

1. Drain flushing

Remove drainage from the air filters regularly.

2. Lubrication

Once lubrication has been started, it must be continued. Use class 1 turbine oil (with no additive), VG32. If other lubricant oil is used, it may cause malfunction. Please contact SMC for suggested class 2 turbine oil (with additive), VG32.

NAMUR Interface 3/5 Port Solenoid Valve

IP67 Compliant, Hygienic Design Type



VFN2120N-X23/-X36

- Hygienic design is adopted
Resin body with less concaves. Direct cleaning of valve is possible (IP67)
- 3 port/5 port available
Function plate realized 3/5 port selectable
- Low power consumption
Power consumption: 0.5 W
- Port threads: NPT1/4, G1/4 available

How to Order



VFN2120N-5 [] - 02 N - [] [] - X23 A - []

Voltage

5	24 VDC
---	--------

Manual

		X23	X36
Nil	Push type	○	—
B	Locking type (Tool required)	○	—
C	Locking type (Manual type)	—	○

○: Available

1/3/5 port thread size

02	1/4"
----	------

1/3/5 port thread type

N	NPT
F	G

Mounting thread type

Nil	UNF10-32 thread
M	M5 x 0.8 thread
N	No mounting thread

Check valve

Nil	Available
0	Not available

CE-compliant

Nil	—
Q	CE-compliant

Valve specifications

A	3 port (Coil side: A port)
B	5 port (Coil side: B port)
C	3 port (Coil side: B port)
D	5 port (Coil side: A port)

Electrical entry

X23	Vertical entry to piping port
X36	Horizontal entry to piping port

Positioners

Regulators

Relays/Valves

Electro-Pneumatic Transducers

Actuators

Detection Conversion Unit

Solenoid Valves

Air Preparation Equipment

Industrial Filters

Piping Materials

VFN2120N-X23/-X36

Standard Specifications

Fluid	Air
Operating pressure range	0.15 to 0.9 MPa
Ambient and fluid temperature	-10 to +60°C
Lubrication	Not required
Manual override	Push type/Locking type (tool required)/ Locking type (manual type)
Enclosure	Equivalent to IP67
Thread port size	1/4"
Flow-rate characteristics (Cv/Effective area)	0.8/11 mm ²
Rated voltage	24 VDC
Allowable voltage fluctuation	-15 to +10% of rated voltage
Type of coil insulation	Class B
Power consumption	0.5 W

Replacement Parts

① Mounting screw

Model	Type	Contents
AXT842-30-19A-2	UNF10-32	With washer/A set of 10 screws
AXT842-30-19A-3	M5 x 0.8	

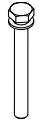

Mounting screw

② Check valve

Model	Contents
AXT842-30-17A	A set of 10 pcs.



Check valve

③ Function plate assembly*

Model	Valve specifications
AXT842-30-10-A	3 port (Coil side: A port)
AXT842-30-10-B	5 port (Coil side: B port)
AXT842-30-10-C	3 port (Coil side: B port)
AXT842-30-10-D	5 port (Coil side: A port)

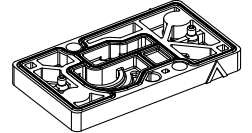

Function plate assembly

* Valve specifications can be freely changed by changing the function plate.

Options

Throttle valve spacer

Part no.	Mounting screw type	Body material	Accessories
AXT842-30-22A-1	UNF10-32	Stainless steel	O-ring for interface (2 pcs.) Mounting screw for spacer (2 pcs.)
AXT842-30-22A-2	M5 x 0.8		
AXT842-30-24A-1	UNF10-32	Aluminum (Black anodized)	
AXT842-30-24A-2	M5 x 0.8		

Dimensions

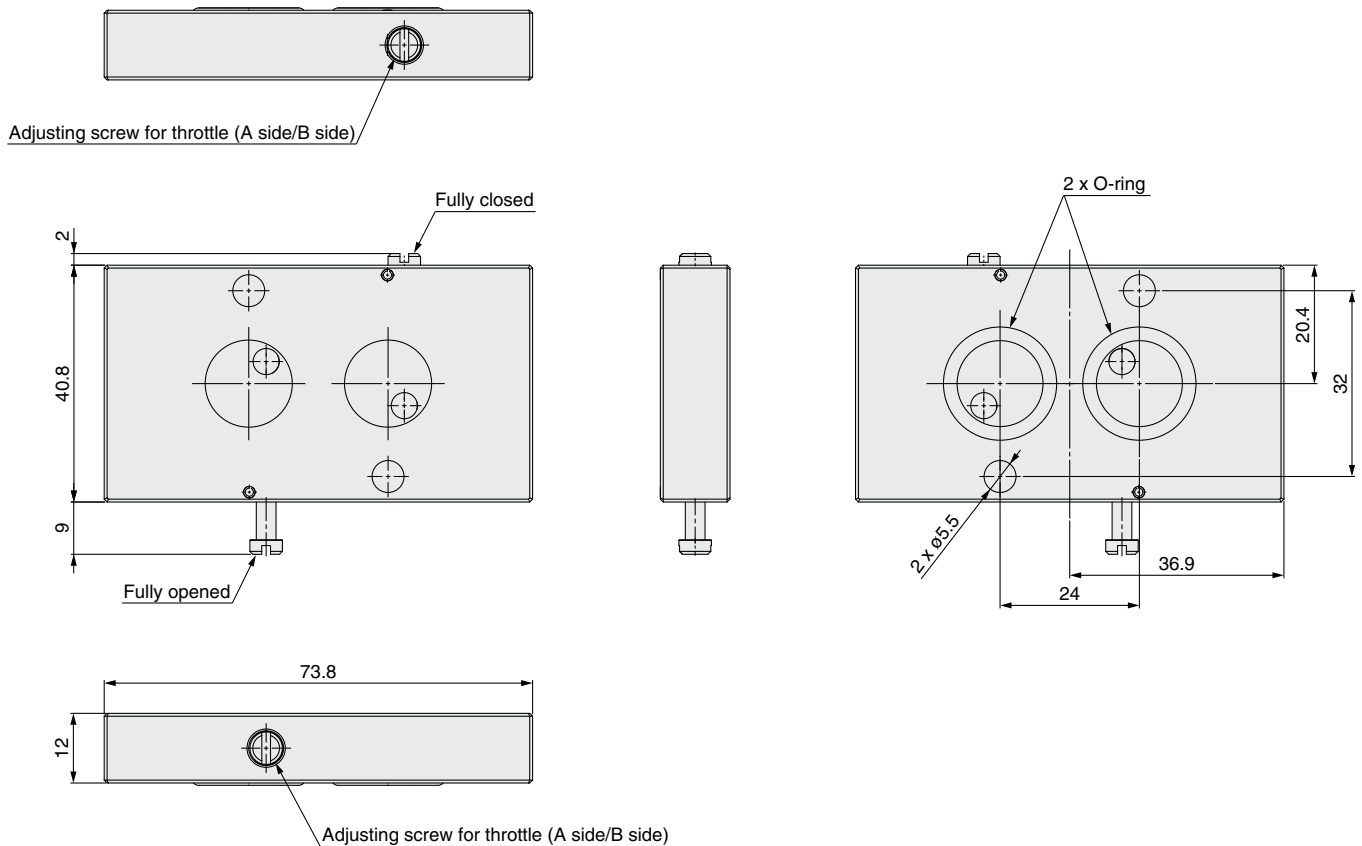

NAMUR Interface 3/5 Port Solenoid Valve IP67 Compliant, Hygienic Design Type **VFN2120N-X23/-X36**

Dimensions

Electrical entry: Vertical VFN2120N-X23A

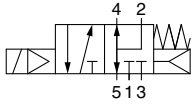

Symbol

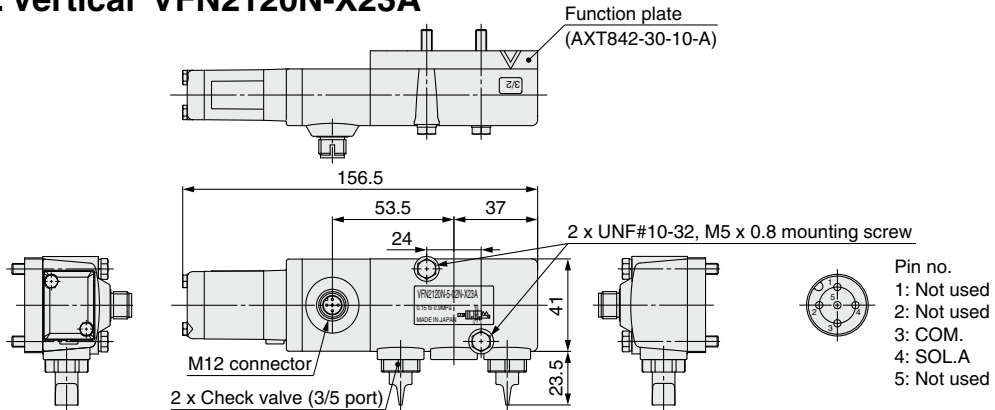

- Pin no.
 1: Not used
 2: Not used
 3: COM.
 4: SOL.A
 5: Not used

M12 connector pin arrangement

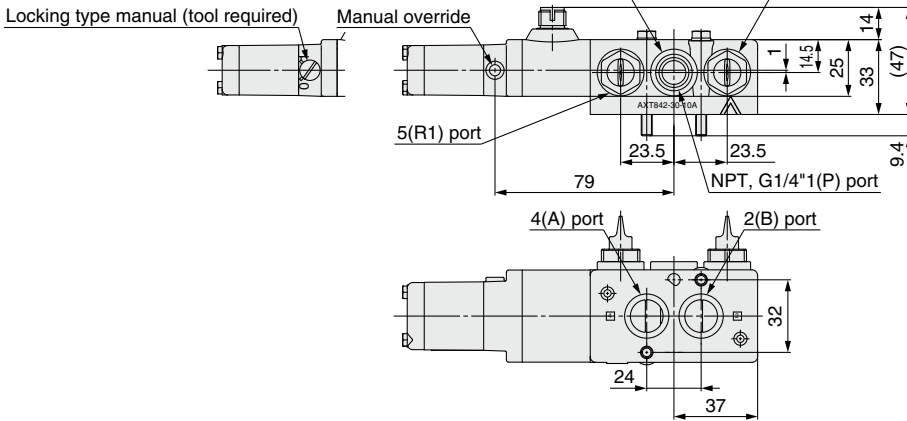

Electrical entry: Vertical VFN2120N-X23B

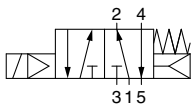

Symbol

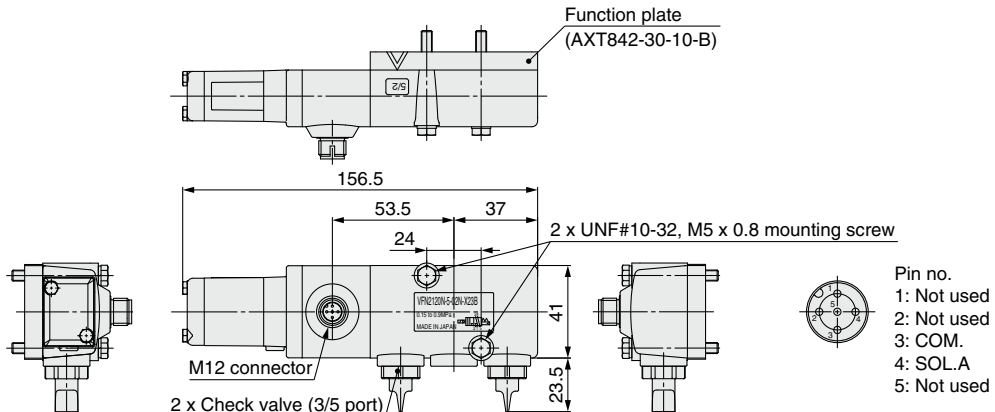

- Pin no.
 1: Not used
 2: Not used
 3: COM.
 4: SOL.A
 5: Not used

M12 connector pin arrangement

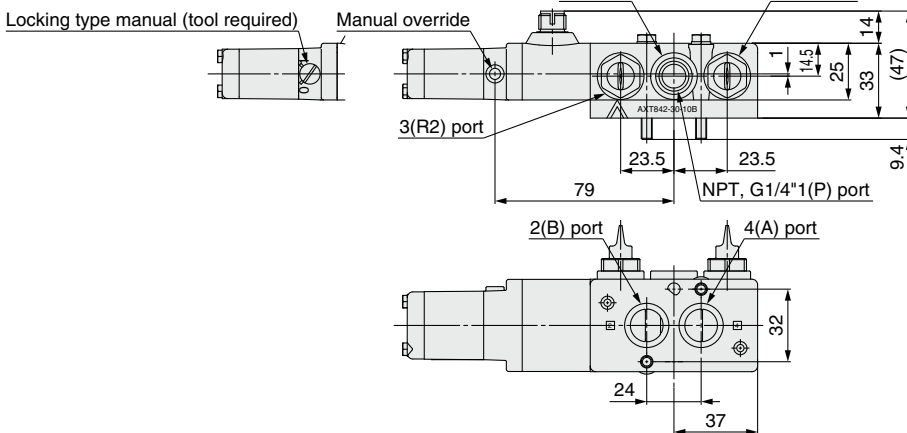

- Positioners
- Regulators
- Relays/Valves
- Electro-Pneumatic Transducers
- Actuators
- Detection Conversion Unit
- Solenoid Valves
- Air Preparation Equipment
- Industrial Filters
- Piping Materials

VFN2120N-X23/-X36

Dimensions

Electrical entry: Vertical VFN2120N-X23C

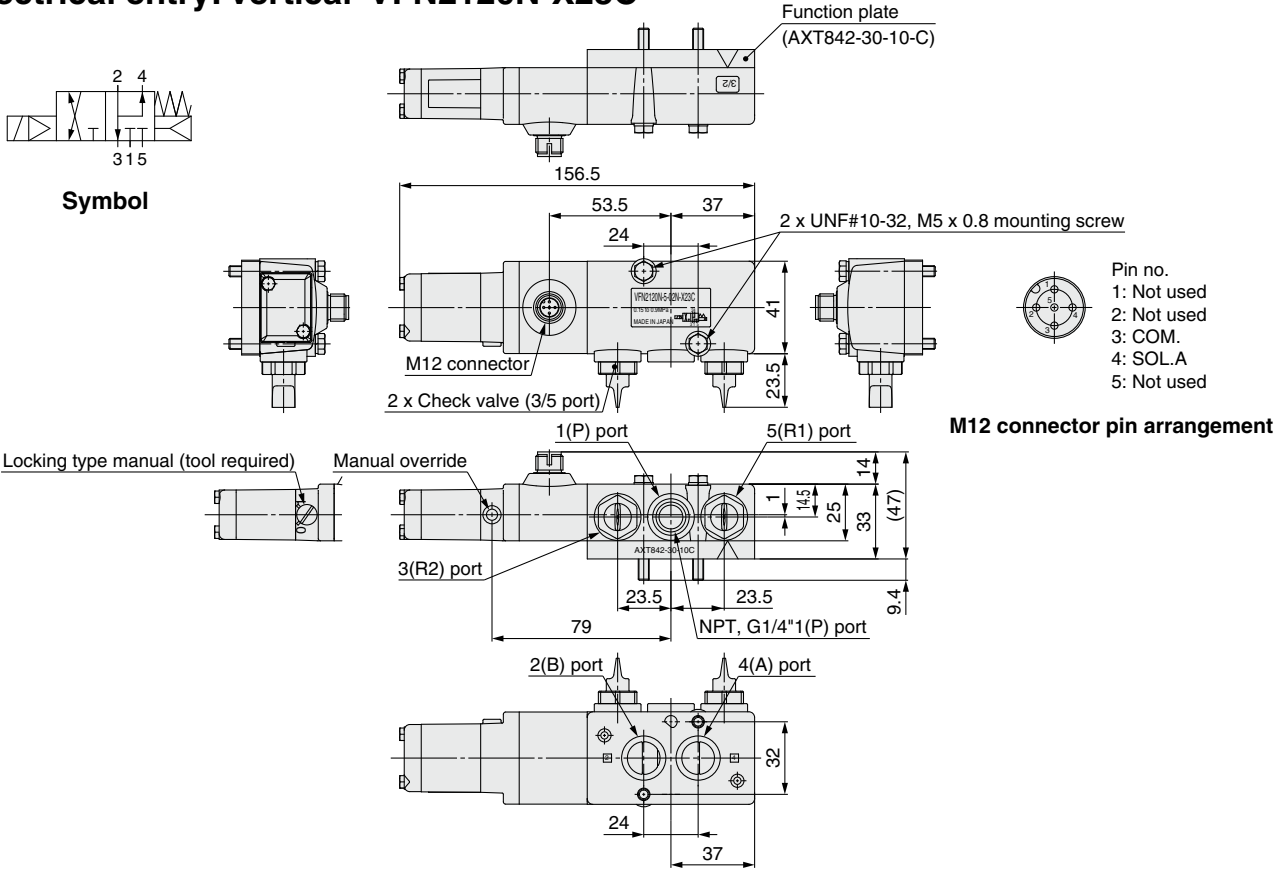

Electrical entry: Vertical VFN2120N-X23D

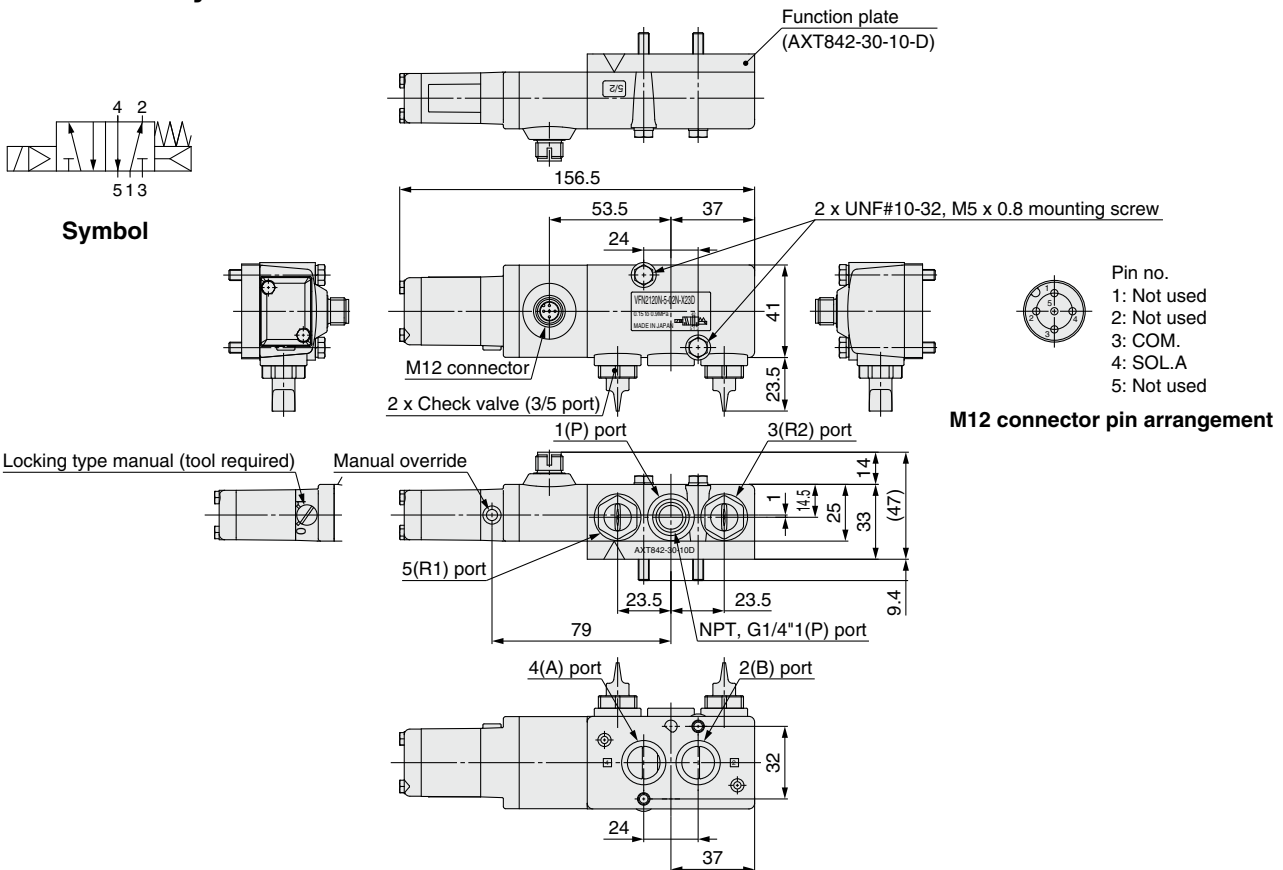

Dimensions

Electrical entry: Horizontal VFN2120N-X36A

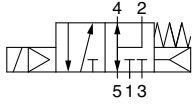

Symbol

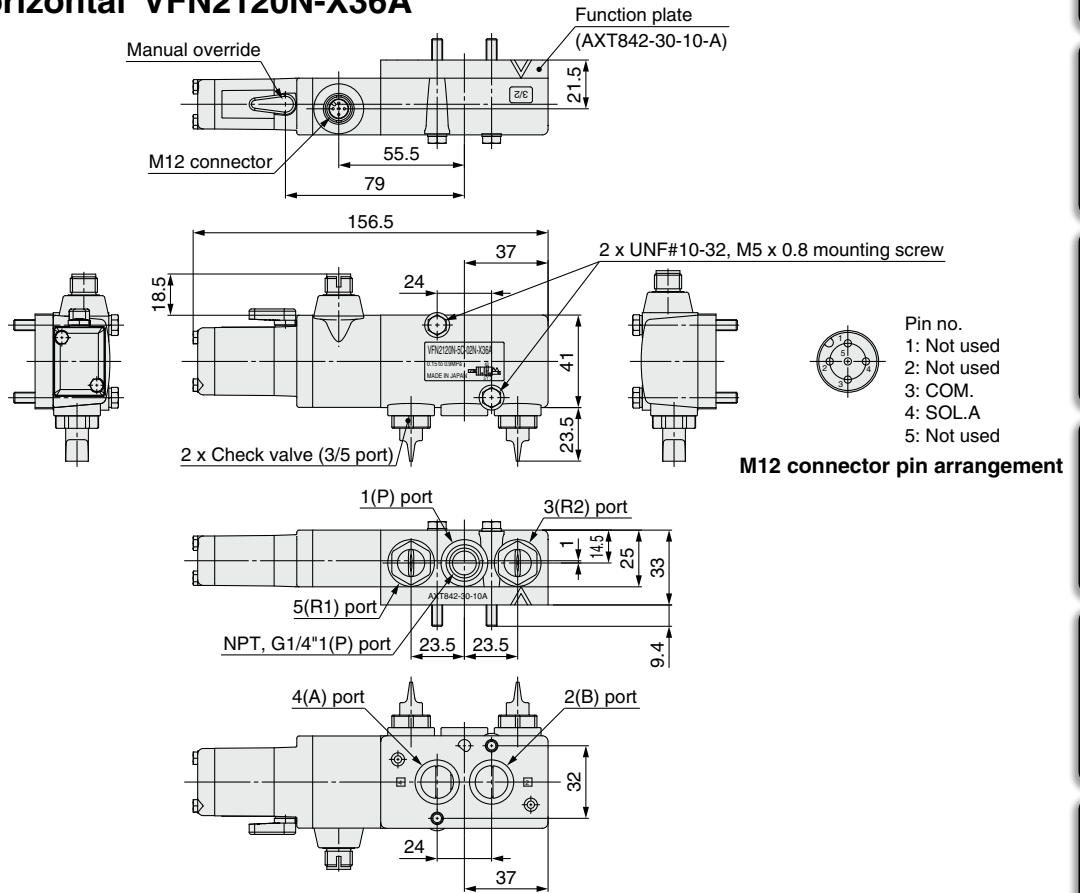

Electrical entry: Horizontal VFN2120N-X36B

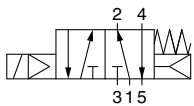

Symbol

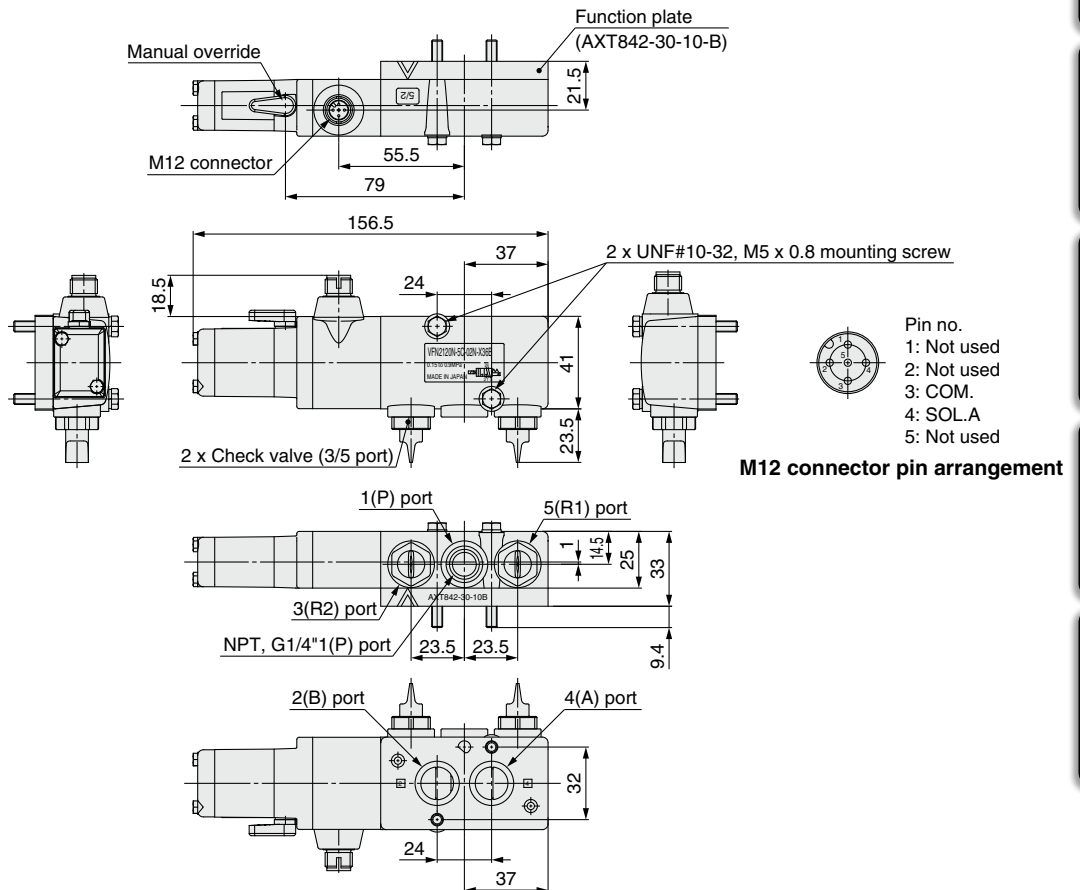

- Positioners
- Regulators
- Relays/Valves
- Electro-Pneumatic Transducers
- Actuators
- Detection Conversion Unit
- Solenoid Valves
- Air Preparation Equipment
- Industrial Filters
- Piping Materials

VFN2120N-X23/-X36

Dimensions

Electrical entry: Horizontal VFN2120N-X36C

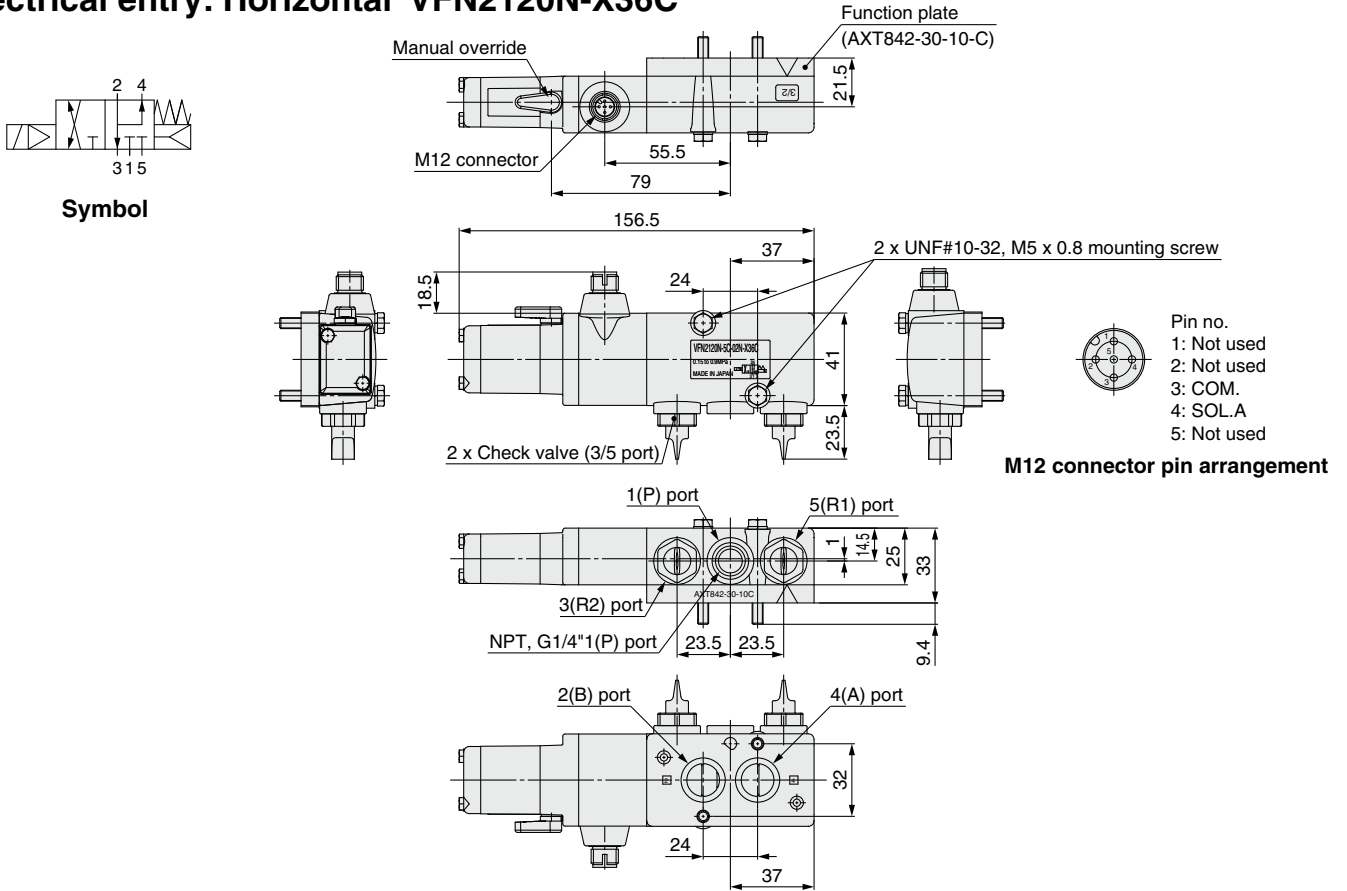

Electrical entry: Horizontal VFN2120N-X36D

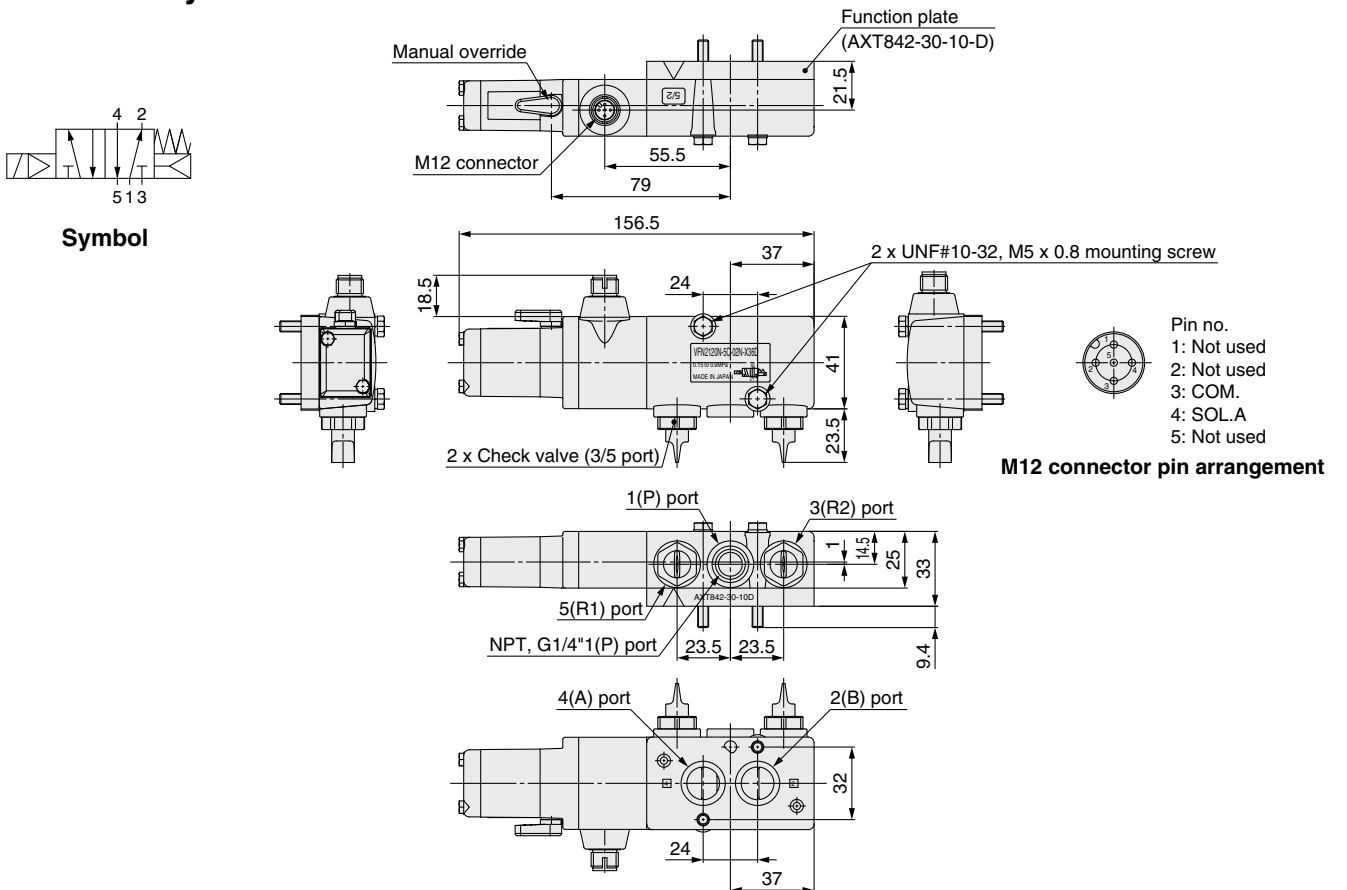

Directional Control Valves

For details, refer to the SMC website. <http://www.smcworld.com>

Intrinsically Safe Explosion-proof System 5 Port Solenoid Valve 51-SY

Operation unit

- Exia II BT4 (TIIS approved product)
- Three types of electrical entry
L-type plug connector, L-type plug connector with cover, Terminal type
- Three types of barriers can be selected.

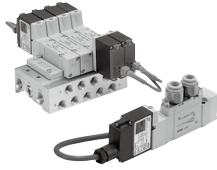

Series	Flow-rate characteristics			Power consumption (W)
	4/2→5/3 (A/B→EA/EB)			
	C [dm ³ /(s·bar)]	b	Cv	
51-SY5000	2.8	0.29	0.66	0.52
51-SY7000	4.1	0.29	1.0	
51-SY9000	9.6	0.43	2.6	

Explosion-proof Type 3/5 Port Solenoid Valve 50-VFE/50-VPE

Operation unit

- d2G4 and Exd II BT4 (TIIS approved product)
- Waterproof: Passed the IPX6 test.
- Exhausting equipment for pilot valve not required. (Common exhaust type for main and pilot valve [50-VFE3000])
- Possible to be into manifold (50-VFE)
- As a selector valve, divider valve, or able to use for vacuum applications. (50-VPE)

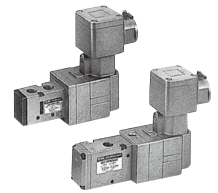

Series	Effective area mm ² (Cv)	Power consumption (W)
50-VFE3000	18 (1.0)	3.5
50-VFE5000	45 (2.5)	
50-VPE500	41.4 (2.3)	
50-VPE700	72 (4)	

Fluid Control Equipment

Best Pneumatics

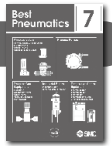

Direct Operated 2 Port Solenoid Valve VX2

Fluid control equipment

- For air, medium vacuum, water, oil, steam
- Flow rate: 20% more flow*
- Height: 10% smaller*
- Lightweight: 30% lighter*
- Body material: Aluminum, resin (air), C37, stainless steel (water, oil, medium vacuum)
- Available with One-touch fittings (resin body)



Series	Valve type	Port size	Orifice diameter (mmø)
VX21/22/23	N.C./N.O.	1/8 to 1/2 ø6 to ø12	2 to 10

* Comparison with SMC conventional model

Pilot Operated 2 Port Solenoid Valve VXD

Fluid control equipment

- For air, water, oil, heated water, high temperature oil
- Height: 7% smaller*

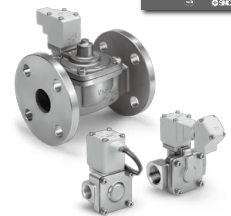

Series	Valve type	Port size	Orifice diameter (mmø)
VXD2	N.C./N.O.	1/4 to 1 32 A to 50 A ø10, ø3/8", ø12	10 to 50

* Comparison with SMC conventional model

Positioners

Regulators

Relays/Valves

Electro-Pneumatic Transducers

Actuators

Detection Conversion Unit

Solenoid Valves

Air Preparation Equipment

Industrial Filters

Piping Materials

Pneumatic Instrumentation Equipment

Air Preparation Equipment



Aftercoolers

Air Cooled Aftercooler/ HAA	Page 98
Water Cooled Aftercooler/ HAW	Page 98

Air Tanks

Air Tank/ VBAT	Page 98
Air Tank/ AT	Page 98

Air Dryers

Refrigerated Air Dryer/ IDF/IDU □ E, D	Page 98
Refrigerated Air Dryer/Large Size Series/ IDF □ F	Page 98
Refrigerated Air Dryer: For Use in Europe, Asia, and Oceania/ IDFA □ E	Page 98
Refrigerated Air Dryer/Large Size Series: For Use in Europe, Asia, and Oceania/ IDFA □ F	Page 98
Refrigerated Air Dryer: For Use in North, Central and South America/ IDFB □ E	Page 99
Heatless Air Dryer/ ID	Page 99
Membrane Air Dryer/ IDG	Page 99

Filters

Water Separator/ AMG	Page 99
Main Line Filter/ AFF	Page 99
Mist Separator/ AM	Page 99
Micro Mist Separator/ AMD	Page 99
Micro Mist Separator with Pre-filter/ AMH	Page 100
Super Mist Separator/ AME	Page 100
Odor Removal Filter/ AMF	Page 100

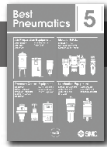

Aftercoolers

Best Pneumatics

Air Cooled Aftercooler **HAA**

- Can cool high temperature compressed air from compressors down to 40°C or less and efficiently remove moisture from the air.
- Cooling equipment is not required for this air cooled type.
- Maintenance is easy and the running cost is reasonable since this is free from concerns such as water supply cut-off or freezing.



Series	Applicable compressor	Air flow capacity L/min (ANR)
HAA	7.5 to 37 kW	1000 to 5700

Water Cooled Aftercooler **HAW**

- Can cool high temperature compressed air from compressors down to 40°C or less and efficiently remove moisture from the air.
- Stable operation is possible even in an environment with a high temperature, high moisture and heavy foreign particles for this water cooled type.



Series	Applicable compressor	Air flow capacity L/min (ANR)
HAW	2.2 to 110 kW	300 to 18000

Air Tanks

Best Pneumatics

Air Tank **VBAT**

- Compact air tank
- Compact connections are possible with booster regulators.
- Can be used as an independent tank.
- Also partially compatible with overseas standards
- Material: Carbon steel, Stainless steel



Series	Port size	Tank capacity (L)
VBAT	3/8, 1/2, 3/4	5, 10, 20, 38

Air Tank **AT**

- Accumulates the compressed air from compressors, also prevents it from being pulsated, and cools it.
 - Use outside Japan is not allowed.
- The AT series air tank is in compliance with the regulations in Japan (Class 2 Pressure Vessel), but is not in compliance with related regulations outside Japan. (This is also applicable when the series is used as a unit.) Please consult with SMC for use of air tanks outside Japan.
- Material: Carbon steel



Series	Port size	Tank capacity (L)
AT	1/2 to 4 ^B flange	100 to 3000

Air Dryers

Best Pneumatics

Refrigerated Air Dryer **IDF/IDU□E, D**

- Air flow capacity: Increased by up to 40%* (SMC comparison)
- Power consumption: Reduced by up to 40%* (SMC comparison)
- Refrigerant: R134a (HFC) [IDF1E to 15E1/IDU3E to 15E1 R407C (HFC) [IDF22E to 370D/IDU22E to 75E]
- Improved corrosion resistance with the stainless steel heat exchanger (IDF4E to 75E/IDU3E to 75E)



* Series IDF□E/IDU□E

Series	Applicable compressor	Air flow capacity m ³ /min (ANR)	
		50 Hz	60 Hz
IDF1E to 75E	0.75 to 75 kW	0.10 to 11.0	0.12 to 12.4
IDF190D to 370D	190 to 370 kW	32.0 to 54.0	38.0 to 65.0
IDU3E to 75E	2.2 to 75 kW	0.32 to 11.0	0.37 to 12.5

Refrigerated Air Dryer/Large Size Series **IDF□F**

- Tolerant of high temperature environment (Ambient temperature 45°C, Inlet air temperature 60°C)
- Exhaust heat amount is reduced by 25%.
- Air-cooled and water-cooled types are available.
- Stainless steel heat exchanger
- Refrigerant: R407C (HFC)



Air-cooled type Water-cooled type

Series	Applicable compressor	Air flow capacity m ³ /min (ANR)	
		50 Hz	60 Hz
IDF100F	100 kW	16	18.8
IDF125F	125 kW	20.1	23.7
IDF150F	150 kW	25	30

Refrigerated Air Dryer: For Use in Europe, Asia, and Oceania **IDFA□E**

- EC Directive compliant product (with CE mark)
- Power supply voltage: Single-phase 230 VAC (50 Hz)
- Refrigerant: R134a (HFC), R407C (HFC). Coefficient of destruction for ozone is zero.
- Improved corrosion resistance with the use of stainless steel, plate type heat exchanger (IDFA4E to 75E)



Series	Air flow capacity m ³ /h (ANR)			Compliant standard
	Outlet air pressure dew point			
	3°C	7°C	10°C	
IDFA3E to 75E	12 to 660	15 to 720	17 to 822	CE

Refrigerated Air Dryer/Large Size Series: For Use in Europe, Asia, and Oceania **IDFA□F**

- Tolerant of high temperature environment (Ambient temperature 45°C, Inlet air temperature 60°C)
- Exhaust heat amount is reduced by 25%.
- Power supply voltage: Three-phase 380 VAC (for Asia and Oceania), 400 VAC (for Europe)
- Stainless steel heat exchanger
- Refrigerant: R407C (HFC)



Series		Outlet air pressure dew point	Air flow capacity m ³ /h (ANR)	Compliant standard
For use in Asia and Oceania	IDFA100F-38	10°C	960	CE
	IDFA125F-38		1210	
	IDFA150F-38		1500	
For use in Europe	IDFA100F-40	3°C	860	
	IDFA125F-40		1100	
	IDFA150F-40		1340	

Positioners

Regulators

Relays/Valves

Electro-Pneumatic Transducers

Actuators

Detection Conversion Unit

Solenoid Valves

Air Preparation Equipment

Industrial Filters

Piping Materials

Air Preparation Equipment

Air Dryers

Best Pneumatics

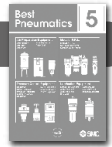

Refrigerated Air Dryer: For Use in North, Central and South America *IDFB□E*

- UL certified product
- Power supply voltage: Single-phase 115 VAC, 230 VAC (60 Hz), Three-phase 460 VAC (60 Hz)
- Refrigerant : R134a (HFC), R407C (HFC)
Coefficient of destruction for ozone is zero.
- Improved corrosion resistance with the use of stainless steel, plate type heat exchanger (IDFB4E to 75E)



Series	Air flow capacity m ³ /h (ANR)			Compliant standards
	Outlet air pressure dew point			
	37°F (2.8°C)	45°F (7.2°C)	50°F (10°C)	
IDFB3E to 75E	10 (17) to 300 (510)	11 (19) to 353 (600)	12 (20) to 406 (690)	UL, CSA

Heatless Air Dryer *ID*

- Supply dry air with a low dew point below -30°C.
- Compact and lightweight without heater and electric control board.
- Possible to check the outlet dew point with the indicator. (Self-regenerative style allows for easy maintenance.)



Series	Outlet air flow rate L/min (ANR)
ID	80 to 780

Membrane Air Dryer *IDG*

- Non-fluorocarbon
- Power supply not required
- Compatible with low dew point
- No vibration or heat discharge
- With a dew point indicator



Series	Outlet air flow rate L/min (ANR)	Standard dew point (°C)
IDG1 to 100	10 to 1000	-20
IDG3H to 100H	25 to 1000	-15
IDG30LA to 100LA	75 to 300	-40
IDG60SA to 100SA	50 to 150	-60

Filters

Best Pneumatics

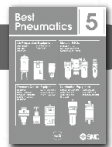

Water Separator *AMG*

- Eliminates water droplets in the compressed air.
- Water droplet removal rate: 99%



Series	Air flow capacity L/min (ANR)	Port size
AMG	300 to 12000	1/8 to 2

Main Line Filter *AFF*

- Can remove impurities such as oil, water and foreign matter in compressed air and can improve the function of a dryer in the downstream, extend the life of precision filter, and prevent trouble with the equipment.



Series	Filtration rating (μm)	Rated flow L/min (ANR)	Port size
AFF	3 (Filtration efficiency: 99%)	300 to 45000	1/8 to 2, JIS 10KFF flange 2 to 4 ^B

Mist Separator *AM*

- Can remove oil mist in compressed air and separate and remove particles such as rust or carbon of 0.3 μm or more.



Series	Filtration rating (μm)	Rated flow L/min (ANR)	Port size
AM	0.3 (Filtration efficiency: 99.9%)	300 to 12000	1/8 to 2

Micro Mist Separator *AMD*

- Can separate and remove aerosol state oil mist in compressed air and remove particles such as carbon or dust of 0.01 μm or more.
- Use this product as a pre-filter for compressed air for precision instruments or clean room requiring higher clean air.



Series	Filtration rating (μm)	Rated flow L/min (ANR)	Port size
AMD	0.01 (Filtration efficiency: 99.9%)	200 to 40000	1/8 to 2, JIS 10KFF flange 2 to 6 ^B

Filters

Best Pneumatics

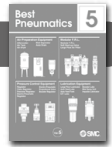

Micro Mist Separator with Pre-filter **AMH**

- The AM series + AMD series have been integrated to achieve a reduction in installation space and in piping labor.
- Can separate and remove aerosol state oil mist in compressed air and remove particles such as carbon or dust of 0.01 μm or more.
- Use this product as a pre-filter for compressed air for precision instruments or clean room requiring higher clean air.



Series	Filtration rating (μm)	Rated flow L/min (ANR)	Port size
AMH	0.01 (Filtration efficiency: 99.9%)	200 to 12000	1/8 to 2

Super Mist Separator **AME**

- Can separate and adsorb aerosol state fine oil particles in compressed air and change the oil lubricating compressed air to oilless air or equivalent.
- Use this product for filtration of compressed air requiring higher clean air for painting lines, compressed air for clean rooms and/or equipment where oils must be avoided.



Series	Filtration rating (μm)	Rated flow L/min (ANR)	Port size
AME	0.01 (Filtration efficiency: 99.9%)	200 to 12000	1/8 to 2

Odor Removal Filter **AMF**

- Efficiently can remove odor in compressed air with an activated carbon element. Use this product in the area such as a clean room where odors must be avoided.
- Activated carbon element with large filtration area



Series	Filtration rating (μm)	Rated flow L/min (ANR)	Port size
AMF	0.01 (Filtration efficiency: 99.9%)	200 to 40000	1/8 to 2, JIS 10KFF flange 2 to 6 ^B

Positioners

Regulators

Relays/Valves

Electro-Pneumatic Transducers

Actuators

Detection Conversion Unit

Solenoid Valves

Air Preparation Equipment

Industrial Filters

Piping Materials

Industrial Filters



Industrial Filters

Industrial Filter/ FGD	Page 102
Industrial Filter/ FGE	Page 102
Industrial Filter/ FGG	Page 102
Bag Filter/ FGF	Page 102
High Precision Filter for Liquids/ FGH	Page 102
Quick Change Filter/ FQ1	Page 102

Elements

Sintered Metal Filter Elements/ EB/ES	Page 103
Fiber Elements/ EH/EHM/EHK	Page 103
Paper Elements/ EP	Page 103
Micromesh Elements/ EM	Page 103



Industrial Filters

Best Pneumatics

Industrial Filter *FGD*

- Low flow rate filtration (Max. 60 L/min)
- Possible to select the antistatic specification (FGDE, FGDF).
- Can be used with a wide range of fluids as iron or stainless steel 316 bowl is used.



Series	Port size	Max. operating pressure	Operating temperature (°C)
FGD	Rc3/8, 1/2, 3/4	0.7, 1 MPa	Max. 80

Industrial Filter *FGG*

- High flow rate filtration (Max. 350 L/min)
- Element replacement is easy with the V-band type. (With cover anti-scattering mechanism)



Series	Port size	Max. operating pressure	Operating temperature (°C)
FGG	Rc2	0.7 MPa	Max. 80

High Precision Filter for Liquids *FGH*

- Filtration efficiency: 99% or more
- Filtration rating: 0.2, 0.4, 2, 4, 6, 13 μm are selectable.



Series	Port size	Max. operating pressure	Operating temperature (°C)
FGH	Rc3/8 to 1	1 MPa	Max. 80

Industrial Filter *FGE*

- Medium flow rate filtration (Max. 230 L/min)
- Element replacement is easy with the V-band type. (With cover anti-scattering mechanism)
- The bolt tightening type can be used with a wide range of fluids as fluoropolymer gasket and stainless steel 304 bowl are used.



Series	Port size	Max. operating pressure	Operating temperature (°C)
FGE	R1, 2	0.7 MPa	Max. 80

Bag Filter *FGF*

- Highly effective for filtration of high turbidity and high viscosity fluids
- High flow rate filtration (Max. 2000 L/min)
- The bag type element catches solid foreign matter, ensuring easy treatment.
- Suitable for filtering cleaning fluids



Series	Port size	Max. operating pressure	Operating temperature (°C)
FGF	Rc2, 4 ^B flange, 6 ^B flange	0.5 MPa	Max. 80

Quick Change Filter *FQ1*

- Low flow rate filtration (Max. 30 L/min)
- No tools required.
- Easy element replacement



Series	Port size	Max. operating pressure	Operating temperature (°C)
FQ1	Rc1/2, 3/4, 1	1 MPa	Max. 80

Positioners

Regulators

Relays/Valves

Electro-Pneumatic Transducers

Actuators

Detection Conversion Unit

Solenoid Valves

Air Preparation Equipment

Industrial Filters

Piping Materials



Elements

Best Pneumatics

Sintered Metal Filter Elements **EB/ES**

- Outstanding mechanical strength, heat resistance and chemical resistance.
- Formed by sintering finely powdered metal, so a high filtration accuracy can be obtained.
- Even if clogging progresses, the element can be reused by cleaning.
- Main applications
Ideal as a check filter for keeping fluid clean. All types of gases, fluids, general solvents and high-temperature fluids



Series	Material	Nominal filtration accuracy (μm)
EB	Bronze	1, 2, 5, 10, 20
ES	Stainless steel 316	40, 70, 100, 120

Fiber Elements **EH/EHM/EHK**

- Four types of materials with different characteristics are available so the filters are applicable to any application.
- Elements are economical because particle capturing capacity is excellent, and element life is long.
- Elements are disposable so maintenance and replacement are easy.
- Main applications

Cotton	Cleaning water, General neutral fluids, General solvents, Dry air
Polypropylene	Plating fluids, General acids, Alkali fluids, Industrial water, Cooling water
Glass fiber	Acid fluids, High-temperature fluids



Series	Element material	Core material	Nominal filtration accuracy (μm)
EH	Cotton	Stainless steel 304	0.5, 1.5, 10, 20
EHM	Polypropylene	Polypropylene	50, 75, 100
EHK	Glass fiber	Stainless steel 316	1, 5, 10, 20

Paper Elements **EP**

- Cartridges are pleated for a large filtration area, and elements are economical due to their long service life.
- Main applications
Ideal for filtration of hydraulic oil, lubricating oil, fuel oil, oils for the liquid gas industry, dry inert gases, and dry air.

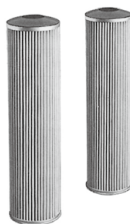

Series	Material	Nominal filtration accuracy (μm)
EP	Filter paper (Cotton, Phenol resin impregnated paper)	5, 10, 20

Micromesh Elements **EM**

- Stainless steel metal mesh has high filtration accuracy.
- Outstanding heat and chemical resistance. Applicable to a wide range of applications.
- Pleated type has 3 times the filtration area of a cylinder.
- Filters are economical because they can be cleaned and repeatedly used.
- Main applications
Please use 40 microns or less as a high precision filter, and 74 microns or higher as a high-grade strainer. All types of gases and fluids, high-temperature fluids

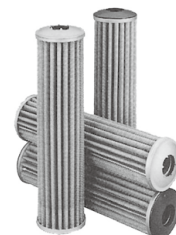

Series	Material	Jointing material	Nominal filtration accuracy (μm)
EM100	Stainless steel 304	Epoxy resin	5, 10, 20
EM500	Stainless steel 316	—	40, 74, 105

Piping Materials



Tubing

Double-layered Tubing for Instrumentation Device (Single-tubed/Double-tubed)/	
IN-241	Page 105
T0604 to T1075-X120/121/166	Page 105
Reinforced Corrugated Cardboard Specification: Longer Length Reel/	
T0604-X64/TH0604-X64	Page 107
Polyurethane Coil Tubing/ TCU	Page 110
Longer Length Reel/ -X3	Page 110

Fittings/S Couplers

Stainless Steel 316 One-touch Fittings/ KQG2	Page 110
Stainless Steel 316 Insert Fittings/ KFG2	Page 110
S Couplers: Stainless Steel Type/ KKA	Page 110

Double-layered Tubing for Instrumentation Device (Single-tubed/Double-tubed)

Series IN-241

Series T0604 to T1075-X120/121/166

- Double-layered tubing with an external layer of vinyl chloride or polyolefin to protect the inner tubing
- Inner tubing color: “Black” or “Black + White”

Standard Specifications



Fluid	Air
Max. operating pressure (at 20°C)	Inner tubing O.D. ø6 : 3.0 MPa ø8 : 2.0 MPa ø10: 2.0 MPa
Ambient and fluid temperature	-40 to +100°C
Inner tubing material	Nylon
Outer layer color	Black
Weight (Reference)	37 kg (T1075-2-300-X166)

Model	Diameter (mm)	Number of cores		Inner tubing color		Material		Outer layer thickness (mm)		Length per roll					
		1	2	Black	Black + White	Vinyl chloride	Polyolefin	0.5	1	100 m		200 m		300 m	
										Reel	Roll	Reel	Reel	Roll	
IN-241-2522-100	O.D. ø6	●		●			●	●		●					
IN-241-2522-300		●		●			●	●					●		
T0604-1-100-X120-A		●		●		●			●						
T0604-1-300-X120-A		●		●		●			●					●	
T0604-2-100-X120-A		I.D. ø4		●		●	●			●	●				
T0604-2-100-X121-A				●		●	●			●	●				
IN-241-1047				●		●	●	●			●		●		
IN-241-2523-100	O.D. ø8	●		●			●	●		●					
IN-241-2523-300		●		●			●	●					●		
T0806-1-100-X120-A		●		●			●		●	●					
T0806-1-300-X120	I.D. ø6	●		●			●	●		●				●	
IN-241-2502-100			●		●		●	●			●				
IN-241-2593-100				●		●		●	●		●				
T1075-1-100-X120-A	O.D. ø10	●		●		●			●	●					
T1075-1-300-X120		●		●		●			●					●	
IN-241-2503-100	I.D. ø7.5		●		●		●	●			●				
IN-241-2594-100			●		●		●	●			●				
T1075-2-300-X166			●		●		●	●						●	

* If you need a different number of cores, different colors or lengths over 300 m, please contact our sales representatives.

Dimensions

Number of cores: 1 core

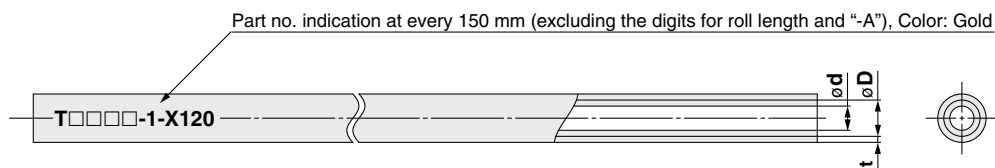

Tube size

O.D. (øD) x I.D. (ød)
ø6 x ø4
ø8 x ø6
ø10 x ø7.5

Outer layer

Thickness (t)
1

* The outer layer thickness for X120 is 1 mm only.

Number of cores: 2 cores

•IN-241-1047 •T0604-2-100-X120-A

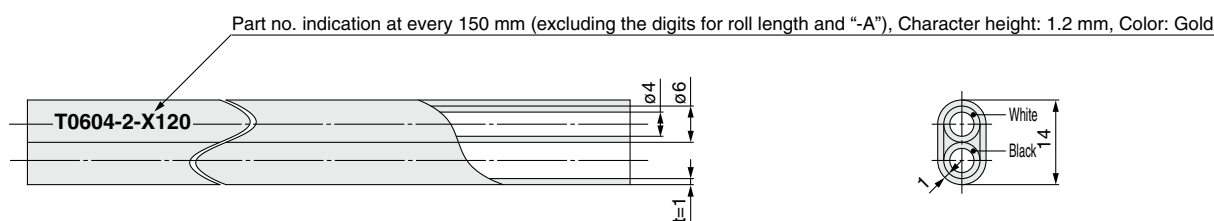

•T0604-2-100-X121-A

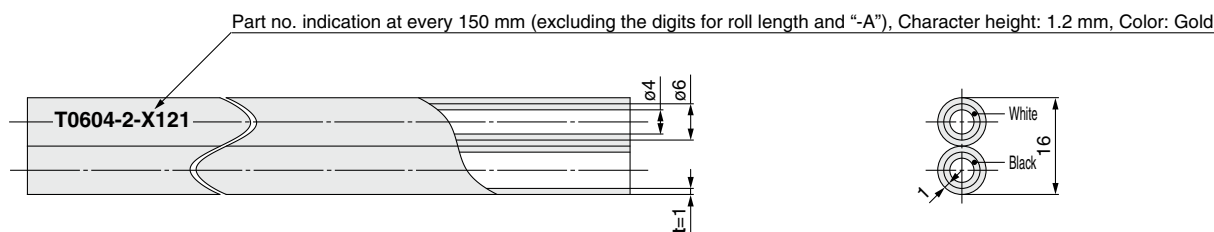

* The part no. is indicated on the product only for T□□□□-X120 and X121.

•Except above mentioned tubing

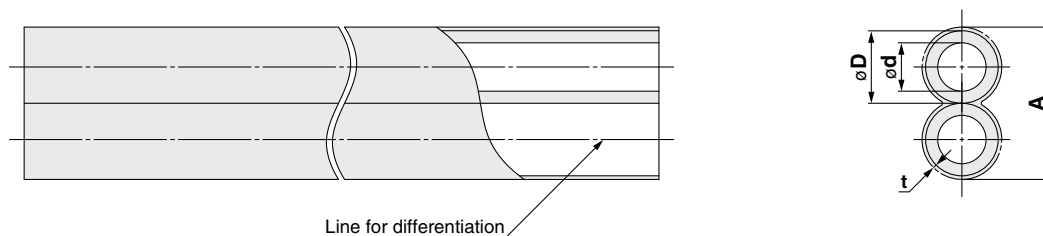

* Inner tubing color: If both of the inner tubing are black, one of them will have a line.

Tube size

O.D. (øD) x I.D. (ød)
ø8 x ø6
ø10 x ø7.5

Outer layer

Thickness (t)
0.5
1

Width

O.D. (øD) x I.D. (ød)	Thickness (t)	Width (A)
ø8 x ø6	0.5	17
	1	18
ø10 x ø7.5	0.5	21
	1	22

Reinforced Corrugated Cardboard Specification/Longer Length Reel Nylon Tubing **T0604-X64**



- Length per roll: 500/250 m
- For general pneumatic tubing
- Nylon Tubing



Reinforced corrugated cardboard

How to measure the minimum bending radius

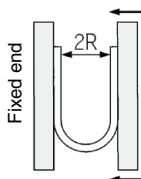

At a temperature of 20°C, bend the tubing into a U shape. Fix one end and gradually move the other end closer. Measure 2R at the point where the outside diameter's rate of change is 10%.

Max. Operating Pressure

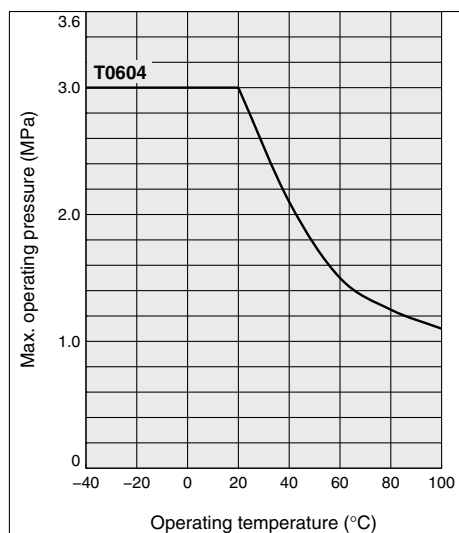

Series

Model	T0604
Tubing O.D. (mm)	6
Tubing I.D. (mm)	4
Black (B)	●
White (W)	●
250 m reel	●
500 m reel	●

Specifications

Fluid		Air, Water
Max. operating pressure (MPa)	20°C or less	3.0
	40°C	2.1
	60°C	1.5
	80°C	1.25
	100°C	1.1
Applicable fittings		One-touch fittings, Insert fittings, Self-align fittings, Miniature fittings
Min. bending radius (mm)	Min. bending radius	24
	Bending value (Reference)	18
Operating temperature		-40 to +100°C, Water: 0 to +70°C (No freezing)
Material		Nylon 12

Note 1) Be sure to operate under the maximum operating pressure and operating temperature conditions using the lower specifications of either the tubing or fittings.

Note 2) Mount an inner sleeve when using metal One-touch fittings in high-temperature environments of 60°C or more. Use self-align fittings at a temperature of 60°C or less.

Note 3) The minimum bending radius is the representative value measured as shown in the left figure.

- Use a tube above the minimum bending radius.
- The tubing may be bent if used under the minimum bending radius. Therefore, refer to the bending value and make sure that the tubing is not bent or flattened.
- Please note that the bending value is not warranted because of the representative value when 2R is measured by the method in the left figure if the tubing is bent or flattened, etc.

How to Order

T0604 B - 500 - X64

Indication of tubing model

Color indication	
Symbol	Color
B	Black (Translucent)
W	White (Material color)

Length per roll

Symbol	T0604
250	●
500	●

⚠ Precautions

Be sure to read this before handling. For Safety Instructions and Fittings and Tubing Precautions, refer to "Handling Precautions for SMC Products" on SMC website, <http://www.smcworld.com>

⚠ Caution

1. Applicable for general industrial water. Please consult with SMC if using other kinds of fluid. Surge pressure must be under the max. operating pressure. If the surge pressure exceeds the maximum operating pressure, it will result in damage to fittings and tubes.
2. Please exercise caution when using this item in a clean room. There is a possibility of plasticizer and other materials precipitating on the tube surface and detracting from the cleanliness level of the room.

Reinforced Corrugated Cardboard Specification/Longer Length Reel FEP Tubing (Fluoropolymer) **TH0604-X64**

RoHS

- Length per roll: 500/250 m
- Operating temperature:
Max. 200°C

It varies depending on the operating pressure. Refer to the graph for the maximum operating pressure.

- **Compatible with the Food Sanitation Law**

- Compatible with the test conforming to the Food Sanitation Law based on the 370th notice given by the Ministry of Health and Welfare in 1959.
- Complies with FDA (Food and Drug Administration) §177-1550 dissolution test.

How to measure the minimum bending radius

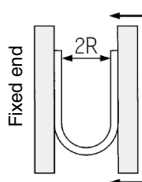

At a temperature of 20°C, bend the tubing into a U shape. Fix one end and gradually move the other end closer. Measure 2R at the point where the outside diameter's rate of change is 5%.

Max. Operating Pressure

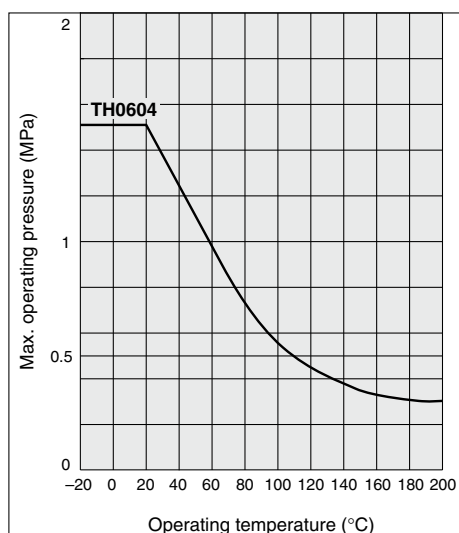

Note) The maximum operating pressure varies dependent on the I.D. bore size even if the O.D. is the same.

Series

Model	TH0604
Tubing O.D. (mm)	6
Tubing I.D. (mm)	4
Translucent (N)	●
250 m reel	●
500 m reel	●

Specifications

Fluid	Air, Water ^{Note 1)} , Inert gas	
Applicable fittings ^{Note 2)}	One-touch fittings, Insert fittings Fluoropolymer fittings: Series LQ ^{Note 3)} Miniature fittings: Series M, MS (Hose nipple type)	
Max. operating pressure (MPa)	20°C	1.5
	100°C	0.55
	200°C	0.3
Refer to below "Max. Operating Pressure."		
Min. bending radius (mm) ^{Note 4)}	Min. bending radius	35
	Bending value (Reference)	20
Operating temperature	Air, Inert gas: -20 to 200°C, Water: 0 to 100°C (No freezing)	
Material	FEP (Fluorinated Ethylene Propylene Resin)	

Note 1) When using a fluid in liquid form, the surge pressure must not exceed the maximum operating pressure. A surge pressure higher than the maximum operating pressure can cause breakage of the fittings, or rupture of the tubing.

Furthermore, an abnormal temperature increase due to adiabatic compression can also result in ruptured tubing.

Note 2) Do not use in locations where the FEP tubing will move.

Be sure to operate under the maximum operating pressure and operating temperature conditions using the lower specifications of either the tubing or fittings.

After long term use or under high temperatures, some fittings leakage may occur due to material deterioration with age. Perform periodic inspections, and if any leakage is detected, replace with a new product immediately.

When the insert and miniature fittings are used over extended periods of time, it may cause leakage due to the material deterioration of age. In such a case, give an additional tightening to the tube connection part. If leakage still occurs after giving an additional tightening, replace the fitting with a new product.

For other precautions, refer to "Fittings & Tubing Precautions." When using the fluoropolymer fittings, refer to the precautions for fluoropolymer fittings in Best Pneumatics No. 6. Select the size after confirming O.D. and I.D.

Note 3) Not applicable to the TH1075 since the I.D. is different.

Note 4) The minimum bending radius is the representative value measured as shown in the left figure.

· Use a tube above the recommended minimum bending radius.

· The tubing may be bent if used under the recommended minimum bending radius. Therefore, refer to the bending value and make sure that the tubing is not bent or flattened.

· Please note that the bending value is not warranted because of the value when 2R is measured by the method in the left figure if the tubing is bent or flattened, etc.

How to Order

TH0604 N - 500 - X64

Indication of tubing model

Color indication

Symbol	Color
N	Translucent

Length per roll

Symbol	TH0604
250	●
500	●

T0604-X64/TH0604-X64

Dimensions

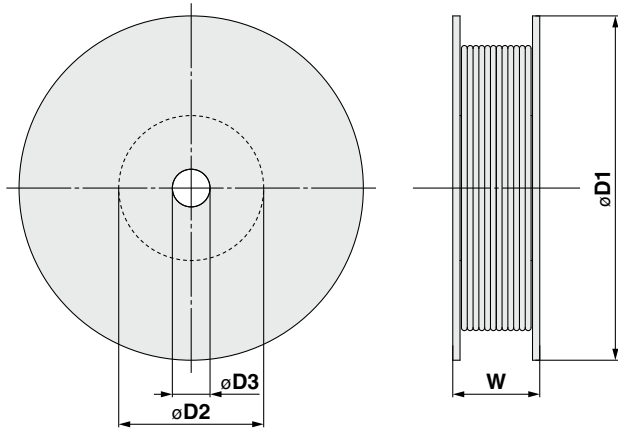

Dimensions

Model	$\phi D1$	$\phi D2$	$\phi D3$	W	Weight (kg)
T0604□-250-X64	475	200	52	120	5.1
T0604□-500-X64	475	200	52	200	9.4
TH0604N-250-X64	475	200	52	120	9.4
TH0604N-500-X64	475	200	52	220	18.5



Tubing

Best Pneumatics

Polyurethane Coil Tubing **TCU**

- Flexible
- Max. operating pressure: 0.8 MPa or less (at 20°C)
- For moving applications

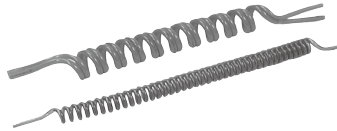

Series	Tubing O.D.	Color	Number of cores	Fluid
TCU	ø4, ø6, ø8	Black	1, 2, 3	Air

Note) Colors other than black are available as Made-to-Order specifications.

Longer Length Reel/-X3 Made to Order

(Please contact SMC for specifications in detail, dimensions, delivery and specifications other than those mentioned above.)

Nylon tubing

100 m reel

Metric size and Inch size except ø16: Suffix "-X3" to the end of part number.

Ex.) T0425R-100-X3

100/150/200/500 m reel

Metric size: Suffix "-X3" to the end of part number.

Ex.) T0425G-500-X3



Made to Order Availability

Part no.	Model											Color
		T0425*	T0604*	T0806*	T1075*	T1209*	TIA01*	TIA05*	TIA07*	TIA11*	TIA13*	
X3	100 m reel	○	○	○	○	○	○	○	○	○	○	Black, White, Red, Blue, Yellow, Green
	150 m reel	○	○	○	○	○	○	○	○	○	○	
	200 m reel	○	○	○	○	○	○	○	○	○	○	
	500 m reel	○	○	○	○	○	○	○	○	○	○	

Fittings/S Couplers

Best Pneumatics



Stainless Steel 316 One-touch Fittings **KQG2**

- Material
Metal parts: Stainless steel 316
Seal parts: Special FKM
- Fluid temperature: -5 to 150°C
- Grease-free
- Can be used with steam.



Series	Applicable tubing O.D.	Operating pressure range	Connection thread
KQG2	ø3.2, ø4, ø6, ø8 ø10, ø12, ø16	-100 kPa to 1 MPa	M, R, Rc
	ø1/8", ø5/32", ø1/4" ø5/16", 3/8", ø1/2"		UNF, NPT

Stainless Steel 316 Insert Fittings **KFG2**

- Material: Stainless steel 316
(Swivel elbow: Stainless steel 316, Special FKM)
- Fluid temperature: -65 to 260°C
(Swivel elbow: -5 to 150°C)
- Grease-free
- Can be used with steam.



Series	Applicable tubing O.D.	Operating pressure range	Connection thread
KFG2	ø4 x ø2.5, ø4 x ø3, ø6 x ø4 ø8 x ø6, ø10 x ø7.5, ø10 x ø8 ø12 x ø9, ø12 x ø10, ø16 x ø13	-100 kPa to 1 MPa	R, Rc
	ø1/8" x ø0.086", ø5/32" x ø0.098" ø1/4" x ø5/32", ø5/16" x ø0.236" ø3/8" x ø1/4", ø1/2" x ø3/8"		NPT

S Couplers: Stainless Steel Type **KKA**

- Body material: Stainless steel 304
- Seal material: Fluororubber (Special FKM)
- Fluid temperature: -5 to 150°C
- Grease-free



Series	Port size							
	R, Rc1/8	R, Rc1/4	R, Rc3/8	R, Rc1/2	R, Rc3/4	R, Rc1	R, Rc1 1/4	R, Rc1 1/2
KKA3	●	●	●					
KKA4		●	●	●				
KKA6			●	●	●			
KKA7				●	●	●		
KKA8					●	●	●	
KKA9						●	●	●

Positioners

Regulators

Relays/Valves

Electro-Pneumatic Transducers

Actuators

Detection Conversion Unit

Solenoid Valves

Air Preparation Equipment

Industrial Filters

Piping Materials

Revision history

- Edition B**
- Models listed in the catalog added. (IP8000, IP5000, CPA2, VFN, etc.)
 - Specific Product Precautions, Safety Instructions added.
 - Number of pages increased from 12 to 116.

SW

Safety Instructions

These safety instructions are intended to prevent hazardous situations and/or equipment damage. These instructions indicate the level of potential hazard with the labels of “**Caution**,” “**Warning**” or “**Danger**.” They are all important notes for safety and must be followed in addition to International Standards (ISO/IEC)*1, and other safety regulations.

 **Caution:** **Caution** indicates a hazard with a low level of risk which, if not avoided, could result in minor or moderate injury.

 **Warning:** **Warning** indicates a hazard with a medium level of risk which, if not avoided, could result in death or serious injury.

 **Danger:** **Danger** indicates a hazard with a high level of risk which, if not avoided, will result in death or serious injury.

- *1) ISO 4414: Pneumatic fluid power – General rules relating to systems.
ISO 4413: Hydraulic fluid power – General rules relating to systems.
IEC 60204-1: Safety of machinery – Electrical equipment of machines.
(Part 1: General requirements)
ISO 10218-1: Manipulating industrial robots – Safety.
etc.

Warning

1. The compatibility of the product is the responsibility of the person who designs the equipment or decides its specifications.

Since the product specified here is used under various operating conditions, its compatibility with specific equipment must be decided by the person who designs the equipment or decides its specifications based on necessary analysis and test results. The expected performance and safety assurance of the equipment will be the responsibility of the person who has determined its compatibility with the product. This person should also continuously review all specifications of the product referring to its latest catalog information, with a view to giving due consideration to any possibility of equipment failure when configuring the equipment.

2. Only personnel with appropriate training should operate machinery and equipment.

The product specified here may become unsafe if handled incorrectly. The assembly, operation and maintenance of machines or equipment including our products must be performed by an operator who is appropriately trained and experienced.

3. Do not service or attempt to remove product and machinery/equipment until safety is confirmed.

1. The inspection and maintenance of machinery/equipment should only be performed after measures to prevent falling or runaway of the driven objects have been confirmed.
2. When the product is to be removed, confirm that the safety measures as mentioned above are implemented and the power from any appropriate source is cut, and read and understand the specific product precautions of all relevant products carefully.
3. Before machinery/equipment is restarted, take measures to prevent unexpected operation and malfunction.

4. Contact SMC beforehand and take special consideration of safety measures if the product is to be used in any of the following conditions.

1. Conditions and environments outside of the given specifications, or use outdoors or in a place exposed to direct sunlight.
2. Installation on equipment in conjunction with atomic energy, railways, air navigation, space, shipping, vehicles, military, medical treatment, combustion and recreation, or equipment in contact with food and beverages, emergency stop circuits, clutch and brake circuits in press applications, safety equipment or other applications unsuitable for the standard specifications described in the product catalog.
3. An application which could have negative effects on people, property, or animals requiring special safety analysis.
4. Use in an interlock circuit, which requires the provision of double interlock for possible failure by using a mechanical protective function, and periodical checks to confirm proper operation.

Caution

1. The product is provided for use in manufacturing industries.

The product herein described is basically provided for peaceful use in manufacturing industries.
If considering using the product in other industries, consult SMC beforehand and exchange specifications or a contract if necessary.
If anything is unclear, contact your nearest sales branch.

Limited warranty and Disclaimer/ Compliance Requirements

The product used is subject to the following “Limited warranty and Disclaimer” and “Compliance Requirements”.

Read and accept them before using the product.

Limited warranty and Disclaimer

1. The warranty period of the product is 1 year in service or 1.5 years after the product is delivered, whichever is first.*2)
Also, the product may have specified durability, running distance or replacement parts. Please consult your nearest sales branch.
2. For any failure or damage reported within the warranty period which is clearly our responsibility, a replacement product or necessary parts will be provided.
This limited warranty applies only to our product independently, and not to any other damage incurred due to the failure of the product.
3. Prior to using SMC products, please read and understand the warranty terms and disclaimers noted in the specified catalog for the particular products.

*2) **Vacuum pads are excluded from this 1 year warranty.**

A vacuum pad is a consumable part, so it is warranted for a year after it is delivered.
Also, even within the warranty period, the wear of a product due to the use of the vacuum pad or failure due to the deterioration of rubber material are not covered by the limited warranty.

Compliance Requirements

1. The use of SMC products with production equipment for the manufacture of weapons of mass destruction (WMD) or any other weapon is strictly prohibited.
2. The exports of SMC products or technology from one country to another are governed by the relevant security laws and regulations of the countries involved in the transaction. Prior to the shipment of a SMC product to another country, assure that all local rules governing that export are known and followed.

Caution

SMC products are not intended for use as instruments for legal metrology.

Measurement instruments that SMC manufactures or sells have not been qualified by type approval tests relevant to the metrology (measurement) laws of each country. Therefore, SMC products cannot be used for business or certification ordained by the metrology (measurement) laws of each country.

 **Safety Instructions** Be sure to read “Handling Precautions for SMC Products” (M-E03-3) before using.

SMC Corporation

Akihabara UDX 15F,
4-14-1, Sotokanda, Chiyoda-ku, Tokyo 101-0021, JAPAN
Phone: 03-5207-8249 Fax: 03-5298-5362
<http://www.smcworld.com>
© 2014 SMC Corporation All Rights Reserved

Specifications are subject to change without prior notice and any obligation on the part of the manufacturer.

D-G

1st printing SW printing SW 11050SZ Printed in Japan.